

# JobMaster<sup>®</sup> Training Station PLC1 Kit

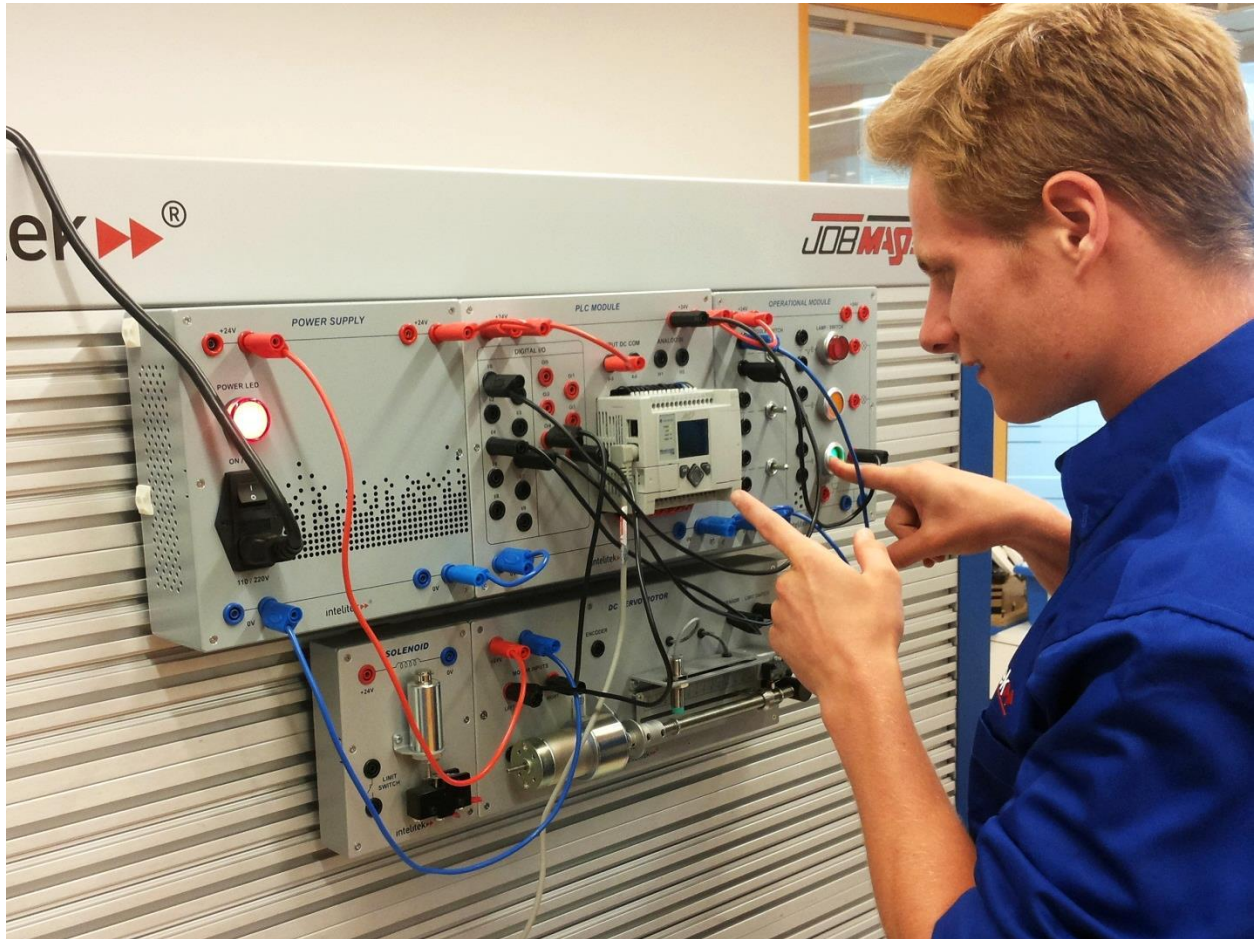

USER MANUAL

*Catalog #34-8000-0002 Rev. B*

**intelitek** 

Copyright © 2024 Intelitek Inc.

JobMaster® Training Station PLC1 Kit User Manual

Catalog #34-8000-0002 Rev. B

January 2024

Every effort has been made to make this book complete and as accurate as possible. However, no warranty of suitability, purpose, or fitness is made or implied. Intelitek Inc. is not liable or responsible to any person or entity for loss or damage in connection with, or stemming from, the use of the software, equipment, and/or the information contained in this publication.

Intelitek Inc. bears no responsibility for errors which may appear in this publication and retains the right to make changes to the software and manual without prior notice.

Intelitek Inc.

Toll Free: 800-221-2763

Phone: 603-413-2600

Fax: 603-437-2137

Email: [info@intelitek.com](mailto:info@intelitek.com)

## Contents

1.	About the PLC1 Kit.....	4
1.1.	Overview .....	4
1.2.	Warnings .....	4
1.3.	Components.....	5
2.	Installing the Modules .....	8
2.1.	Module Overview.....	8
2.2.	Mounting the Modules .....	9
2.3.	Making Electrical Connections .....	10
3.	Parts and Specifications.....	11
3.1.	DC Servo Motor Module .....	11
3.2.	Solenoid Module .....	15
3.3.	Electrical Connectors .....	16
4.	Examples of Use.....	17
4.1.	Example 1: Energizing the Solenoid .....	17
4.2.	Example 2: Running the Motor .....	20

# 1. About the PLC1 Kit

## 1.1. OVERVIEW

The JobMaster® Training Station (JMTS) PLC1 Kit is a training set that helps demonstrate the principles of programmable controllers and sequence control systems.

The kit has a number of devices which can be activated and controlled.

The two modules included in the kit have several different types of banana sockets, each of which can be accessed using the electrical connectors.

- Red (+24V) and blue (0V) sockets are voltage inputs.
- Black sockets are outputs or switch connections.

## 1.2. WARNINGS



- ⊘ **Warning:** *Avoid damaging the PLC1 Kit:*
  - Do not touch or tamper with the DC motor unit, especially when it is in motion.
  - Do not tamper with the solenoid or limit switches.
- ⊘ **Warning:** *To immediately halt all system operation, switch OFF the power supply module.*
- ⊘ **Warning:** *Make sure you do not short the 24V socket to ground when connecting the wires. It is strongly recommended that you prepare a circuit diagram before making an actual connection.*

## 1.3. COMPONENTS

### 1.3.1. In Your Kit

Your PLC1 Kit includes these items:

Qty.	Catalog #	Part Name
1	22-0230-1000	DC servo motor module
1	22-0230-2000	Solenoid module
		Electrical connectors (banana plug cables)
4	411658	Red (200mm)
4	411659	Blue (200mm)
5	411660	Black (200mm)
1	411661	Red (400mm)
1	411662	Blue (400mm)
1	411663	Black (400mm)
2	411664	Red (600mm)
2	411665	Blue (600mm)
2	411666	Black (600mm)
2	411667	Red (1100mm)
2	411668	Blue (1100mm)
2	411669	Black (1100mm)

### 1.3.2. Prerequisites

The PLC1 Kit requires the following items:

- JMTS mounting panel
- JMTS power supply module
- JMTS operational module

Highly recommended items include:

- Allen-Bradley MicroLogix 1100 PLC module with PLCMotion software
- Siemens S7-1200 PLC module with SIMATIC STEP 7 TIA Portal software

Optional items include:

- JMTS relay module
- JMTS HMI module

### 1.3.3. DC Servo Motor Module

The following diagram shows the DC servo motor module. Numbers in the diagram refer to the component list below.

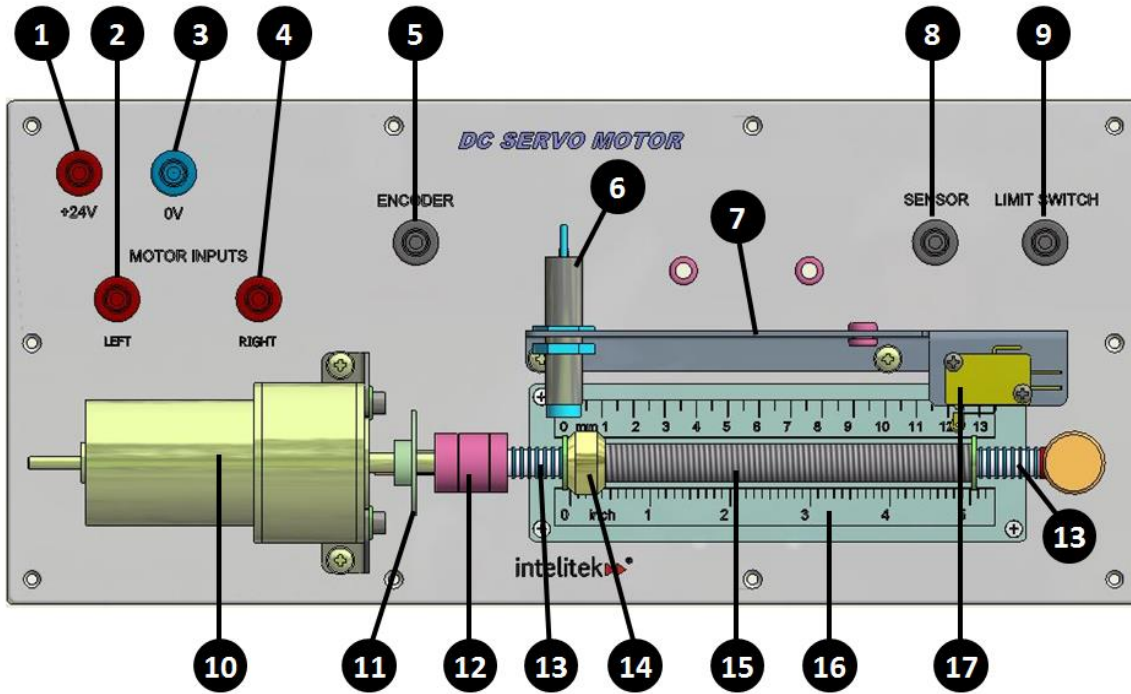

- |  |   |
|--|---|
| 1. +24V voltage input                  | 10. DC servo motor, Pittman GM9213  |
| 2. Leftward motor input                | 11. Optical encoder with disk (The encoder's LED and photoelectric sensor units are underneath the disk.) |
| 3. 0V voltage input                    | 12. Coupling  |
| 4. Rightward motor input               | 13. Stopper spring and washer   |
| 5. Encoder output socket               | 14. Nut with pointer  |
| 6. Inductive sensor, M12–NPN           | 15. Lead screw  |
| 7. Bracket for sensor and limit switch | 16. 2 Rulers, 15cm/6"   |
| 8. Sensor output socket                | 17. Limit switch  |
| 9. Limit switch output socket          |   |

### 1.3.4. Solenoid Module

The following diagram displays the Solenoid Module. Numbers in the diagram refer to the component list.

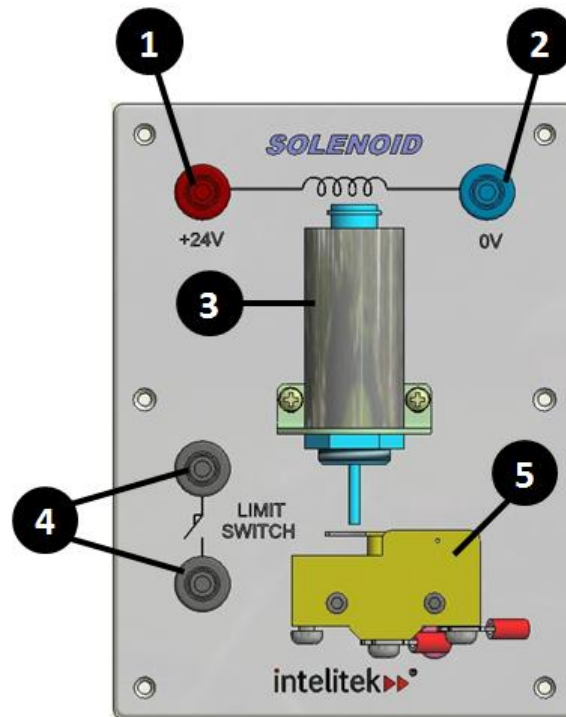

- |                                    |                         |
|------------------------------------|-------------------------|
| 1. +24V voltage input              | 4. Limit switch sockets |
| 2. 0V voltage input                | 5. Limit switch         |
| 3. Solenoid, Shindengen's M250 31H |                         |





# 2. Installing the Modules

## 2.1. MODULE OVERVIEW

The electrical modules (listed in the table below) are optional accessories that can be mounted onto the slots of the JMTS panel. The recommended location of the attachment of these modules is at the top of one of the slotted sides. The power supply module should be placed at the far left side of one of the slotted panels with the HMI module on the far right side. PLC modules should be mounted to the left of the HMI module.

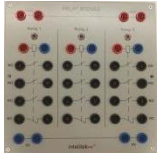
If your JMTS has a swing arm with a monitor, the HMI should be mounted on the side next to the arm.

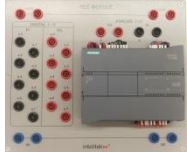
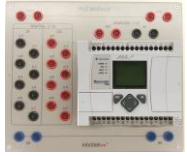
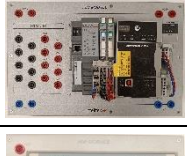
Tools are not required for the mounting of these modules.

Module	Catalog Number	Recommended Location at the Top of the Slotted Panel	Image
Power Supply Module	10-2550-1000	Far left	
Relay Module	10-2550-2000	Adjacent to Power Supply Module	
Operational Module	10-2550-3000	Center	
Siemens S7-1200 PLC Module	10-2550-4000	Adjacent to the HMI Module	
MicroLogix 1100 PLC Module	10-2550-6000	Adjacent to the Operational Module	
CompactLogix PLC Module	10-2550-7000	Adjacent to the HMI Module	
HMI Module	10-2550-5000 / 10-2550-8000	Far right	



## 2.2. MOUNTING THE MODULES

The PLC1 Kit modules have several “legs” that allow them to be inserted securely into the slots of the JMTS mounting panel.

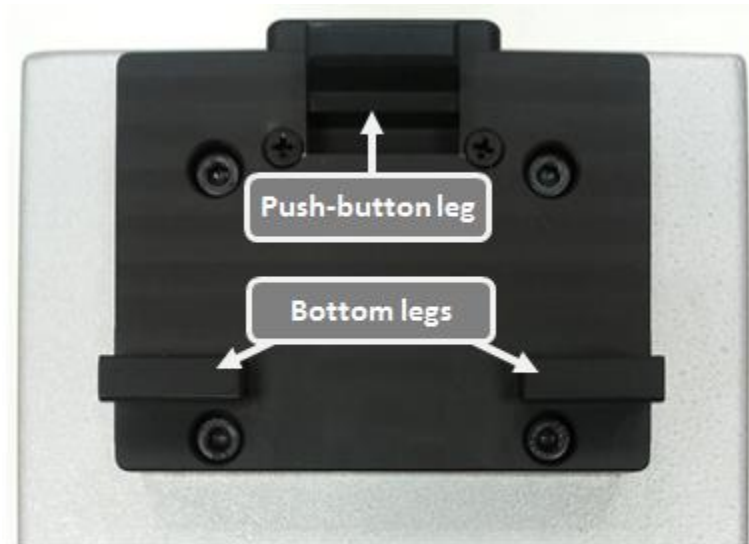

**To mount a module onto the panel:**

1. Insert the module's top push button leg into one of the thinner slots of the panel.
2. Push the module upwards until the bottom legs are inserted into the slotted panel as well.

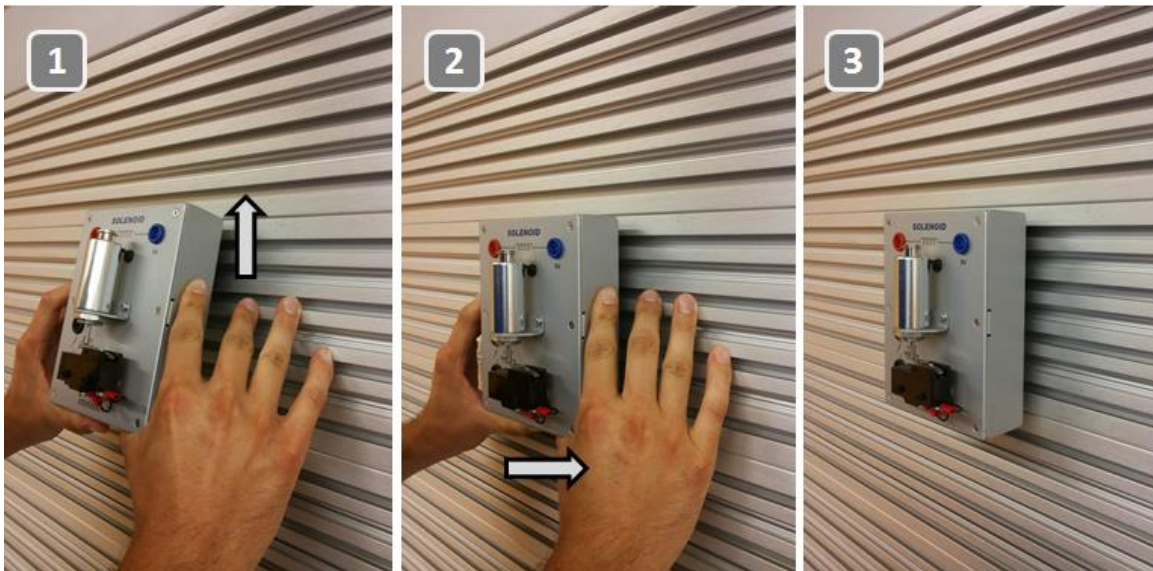

**To remove a module from the panel:**

1. Push the module upwards until the bottom legs are free of the panel.
2. Pull the module outwards and then downwards to remove it.

## 2.3. MAKING ELECTRICAL CONNECTIONS

Electric connections may be made to a power bar that can be placed in the cabinet of the JMTS Bench. The power bar's cable can be drawn through the hole of the cabinet floor and plugged it into an electrical wall socket.

Draw the Power Supply Module's power cable and any other electrical cables behind or to the side of the JMTS Mounting Panel. Plug the cable into the power bar or directly into a wall socket.

Electric connections may be made to a power bar that can be placed in the cabinet of the JMTS Bench. The power bar's cable can be drawn through the hole of the cabinet floor and plugged it into an electrical wall socket.

Draw the Power Supply Module's power cable and any other electrical cables behind or to the side of the JMTS Mounting Panel. Plug the cable into the power bar or directly into a wall socket.



# 3. Parts and Specifications

This section describes the individual elements of the two PLC1 Kit modules and the electrical connectors.

ⓘ *Note: The diagrams in this section are for illustrative purposes and do not necessarily represent the actual components of the PLC1 Kit modules.*

## 3.1. DC SERVO MOTOR MODULE

### 3.1.1. DC Servo Motor

The module’s DC servo motor drives a lead screw.

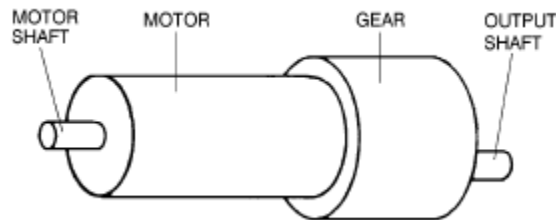

#### 3.1.1.1. Activation

The direction of motor revolution is determined by the polarity of the operating voltage: positive DC voltage turns the motor in one direction, while negative DC voltage turns it in the opposite direction.

- When the **Right** motor input socket is connected to 24VDC, the motor rotates counter-clockwise.
- When the **Left** motor input socket is connected to 24VDC, an internal relay in the panel reverses the polarity, causing the motor to rotate clockwise.

In addition, the motor can be moved by twisting the motor shaft manually.

#### Specifications: Pittman GM9213 DC Servo Motor

Motor Size Data (25°C)			
Parameter	Symbol	Units	Specifications
Motor Constant	$K_M$	oz • in/√W	3.01
Peak Torque (Stall)	$T_P$	oz • in	41.3
No Load Speed	$S_0$	rpm	6151
Motor Friction Torque	$T_F$	oz • in	0.60
Viscous Damping Factor	$D$	oz • in/krpm	0.0387
Damping Constant	$K_D$	oz • in/krpm	6.68
Electrical Time Constant	$\tau_E$	ms	0.85
Mechanical Time Constant	$\tau_M$	ms	9.25
Thermal Time Constant	$\tau_{TH}$	min	12.0

Motor Size Data (25°C)			
Thermal Impedance	$R_{TH}$	deg C/W	17.1
Maximum Winding Temperature	$\theta_{MX}$	deg C max	$5.9 \times 10^{-4}$
Motor Inertia	$J_M$	oz • in • s <sup>2</sup>	10.1
Motor Weight	$W_M$	oz	2.403
Motor Length	$L_1$	in max	2.354

Motor Winding Data (25°C)			
Parameter	Symbol	Units	Specifications
Voltage	E	V	30.3
Torque Constant	KT	oz • in/A	6.50
Back EMF Constant	KE	V/krpm	4.81
Terminal Resistance	RT	ohms	4.62
Inductance	L	mH	3.97
No Load Current	IO	A	0.13
Peak Current (Stall)	IP	A	6.55

Spur Gearmotor Data (25°C)			
Gear Ratio 127.78			
Parameter	Symbol	Units	Output Shaft
N.L. Speed	$S_0$	rpm	48.1

### 3.1.2. Lead Screw and Nut

A lead screw with a nut is connected to the motor output shaft by means of a coupling. The lead screw converts the rotary motion of the DC motor into linear motion of the nut.

#### 3.1.2.1. Activation

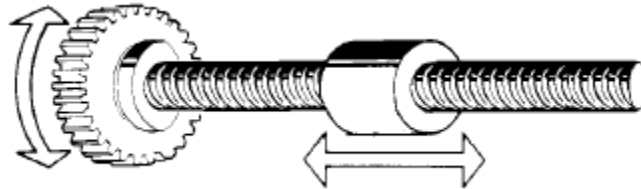

As the motor rotates, a nut travels along the length of the lead screw.

- When the **Right** motor input socket is connected to 24VDC, the nut moves to the right.
- When the **Left** motor input socket is connected to 24VDC, the nut moves to the left.

As the nut moves, the distance traveled can be measured on the rulers by the pointer attached to the nut.

The nut can be detected by two types of sensors: a mechanical limit switch and an inductive proximity sensor.

#### 3.1.2.2. Specifications

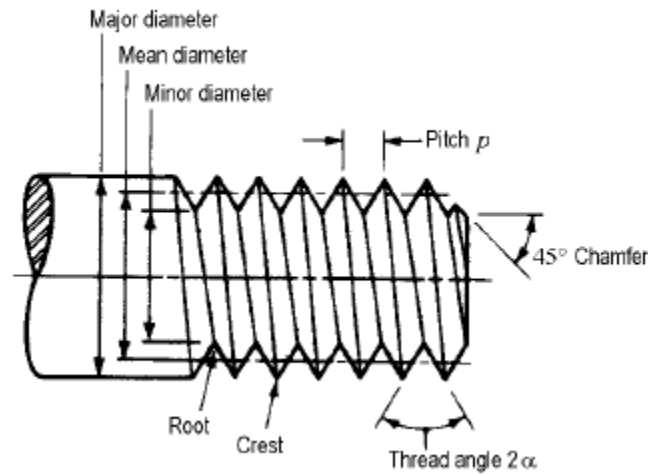

	Coarse-Pitch Series		
Nominal Major Diameter (d)	Pitch (p)	Tensile-Stress Area (At)	Minor-Diameter Area (Ar)
12	1.75	84.3	76.3

### 3.1.3. Optical Encoder

The module’s encoder has a photoelectric sensor and a one-slot rotating disk.

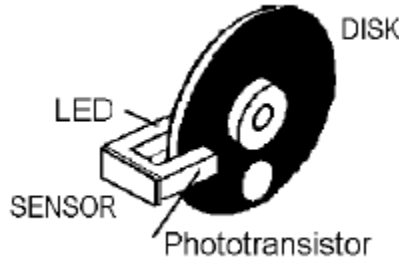

#### 3.1.3.1. Activation

When the disk blocks the light beam from the LED to the phototransistor, an output off (0) signal is sent to the PLC via the **Encoder** output socket.

When the slot allows the light beam to pass from the LED to the phototransistor, an output on (1) signal is sent to the PLC via the **Encoder** output socket.

#### 3.1.3.2. Specifications

<b>Supply voltage</b>	5 to 24 VDC ±10%
<b>Current</b>	100mA
<b>Configuration</b>	NPN, Normally Open (sink)

### 3.1.4. Limit Switch

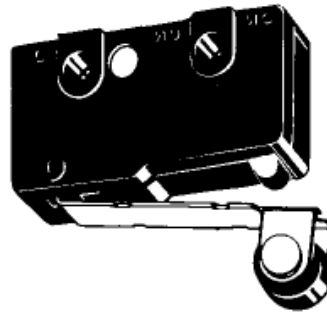

#### 3.1.4.1. Activation

When the nut on the lead screw applies force to the limit switch’s actuator (the roller lever), the switch is activated.

When the switch is activated, an output on (1) signal is sent to the PLC via the **Limit Switch** output socket.

#### 3.1.4.2. Specifications

<b>Configuration:</b>	Normally open
-----------------------	---------------

### 3.1.5. Inductive Proximity Sensor

This sensor can be moved horizontally within the bracket slot. It can also be adjusted vertically.

### 3.1.5.1. Activation

The sensor's switch is activated when the sensor detects an electrically conductive material (such as the ferrous nut on the lead screw).

When the switch is activated, an output on (1) signal is sent to the PLC via the **Sensor** output socket. Also, an LED on the sensor is illuminated.

When the electrically conductive material (the nut) is removed from the sensor's field, the switch reverts to its (normally open) initial state. The LED shuts off.

### 3.1.5.2. Specifications

<b>Supply Voltage</b>	10–30 VDC
<b>Maximum Consumption</b>	200mA
<b>Configuration</b>	NPN, Normally Open (sink)
<b>Thread</b>	M12 thread
<b>Length</b>	50mm
<b>Normal Operating distance</b>	6mm

## 3.2. SOLENOID MODULE

The solenoid module uses a tubular solenoid housed in a mild steel case.

### 3.2.1. Solenoid

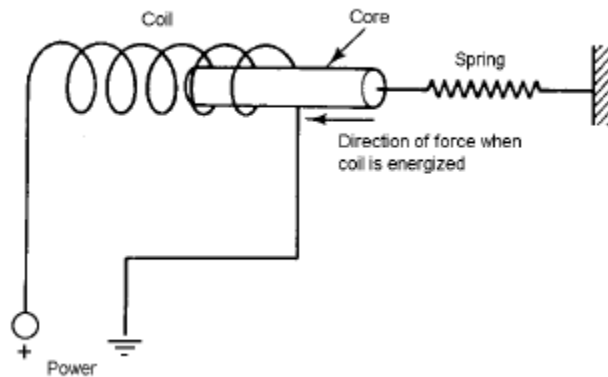

#### 3.2.1.1. Activation

When the solenoid input socket is connected to 24VDC, the solenoid coil is energized; the magnetic field pulls the core into the coil, and the plunger is pushed into the actuator of the limit switch.

When de-energized, the spring pulls the core out of the coil.

**3.2.1.2. Specifications**

Duty Cycle (on time / "on time"+"off time") x 100	100% Continuous	50% or less	25% or less	10% or less
Resistance (20°C)	Volts DC	Volts DC	Volts DC	Volts DC
57.6	24	34	48	76

**3.2.2. Limit Switch**

**3.2.2.1. Activation**

This limit switch is activated when the stroke of the solenoid plunger applies force to the actuator (hinge lever).

When the switch is activated, an output on (1) signal is sent to the PLC through the Limit Switch socket.

**3.2.2.2. Specifications**

<b>Configuration</b>	Normally open
----------------------	---------------

**3.3. ELECTRICAL CONNECTORS**

The PLC1 Kit requires the use of electrical connectors, also known as banana plug cables. These are flexible leads with 4mm insulated stackable plugs.

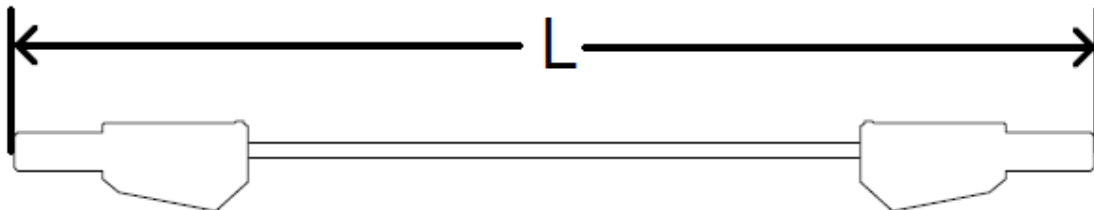



## 4. Examples of Use

The following examples are for demonstration purposes only, and are not necessarily recommended for student use.

### 4.1. EXAMPLE 1: ENERGIZING THE SOLENOID

In this application, turning on the operational panel's upper switch energizes the solenoid. The solenoid module's limit switch then closes, allowing power to flow through it and illuminate the red lamp.

#### 4.1.1. Requirements

- PLC1 Kit solenoid module
- Electrical connectors
- JMTS mounting panel
- MicroLogix 1100 PLC module or Siemens S7-1200 PLC module
- Computer with PLCMotion software (for the MicroLogix 1100 PLC module) or SIMATIC STEP 7 TIA Portal software (for the S7-1200 PLC module)
- Power supply module
- Operational module

#### 4.1.2. Programming

Using PLCMotion (for Allen-Bradley) or TIA Portal (for Siemens), build the ladder diagram and tag the instructions for the I/Os of your controller as shown.

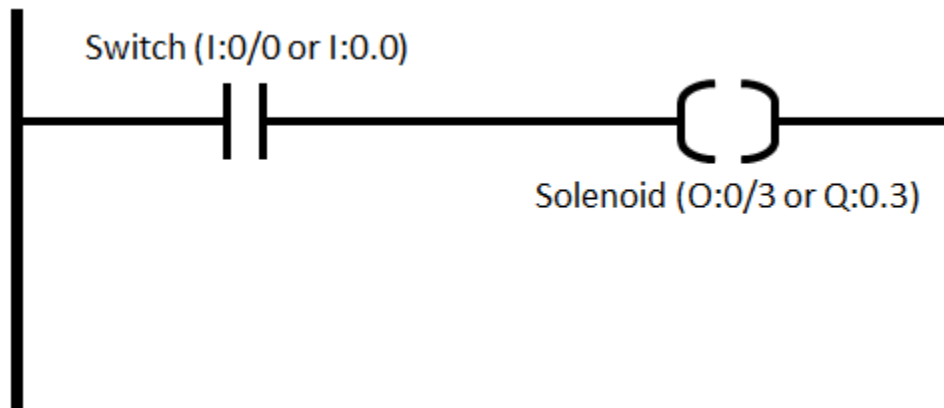

### 4.1.3. Wiring

- ① *Note: The colors of the electrical connectors in the schematic below are for illustrative purposes only. You can use any color or length of connector for any of the connections.*

#### Using the MicroLogix 1100 PLC Module:

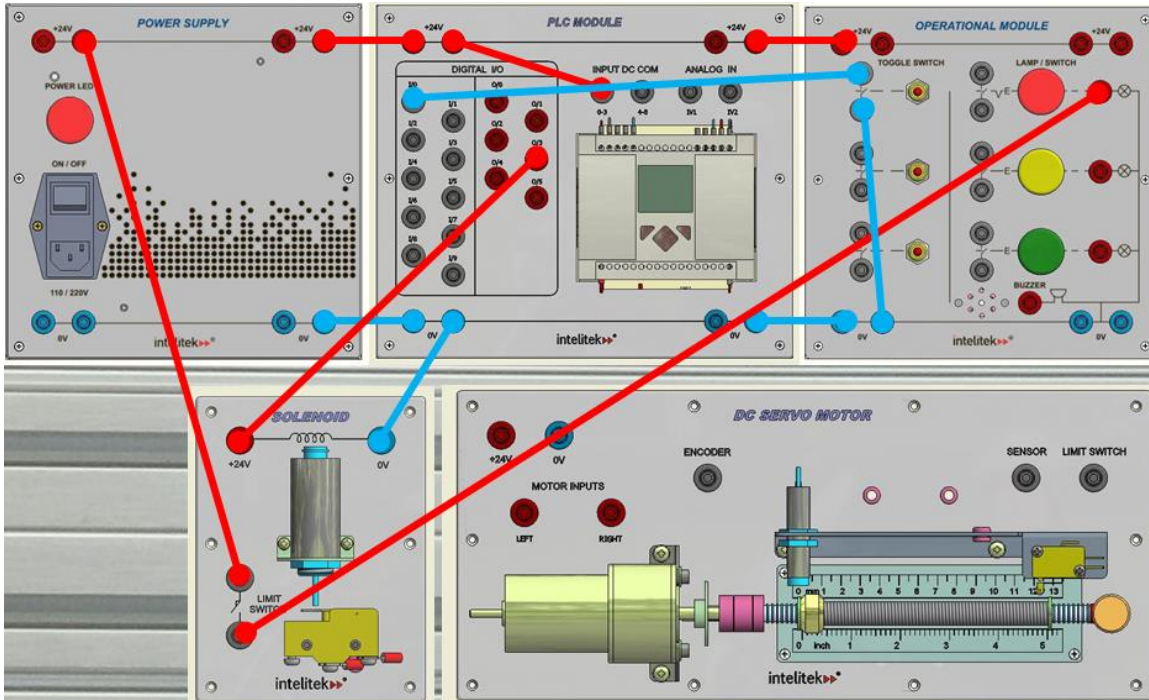

#### Using the Siemens S7-1200 PLC Module:

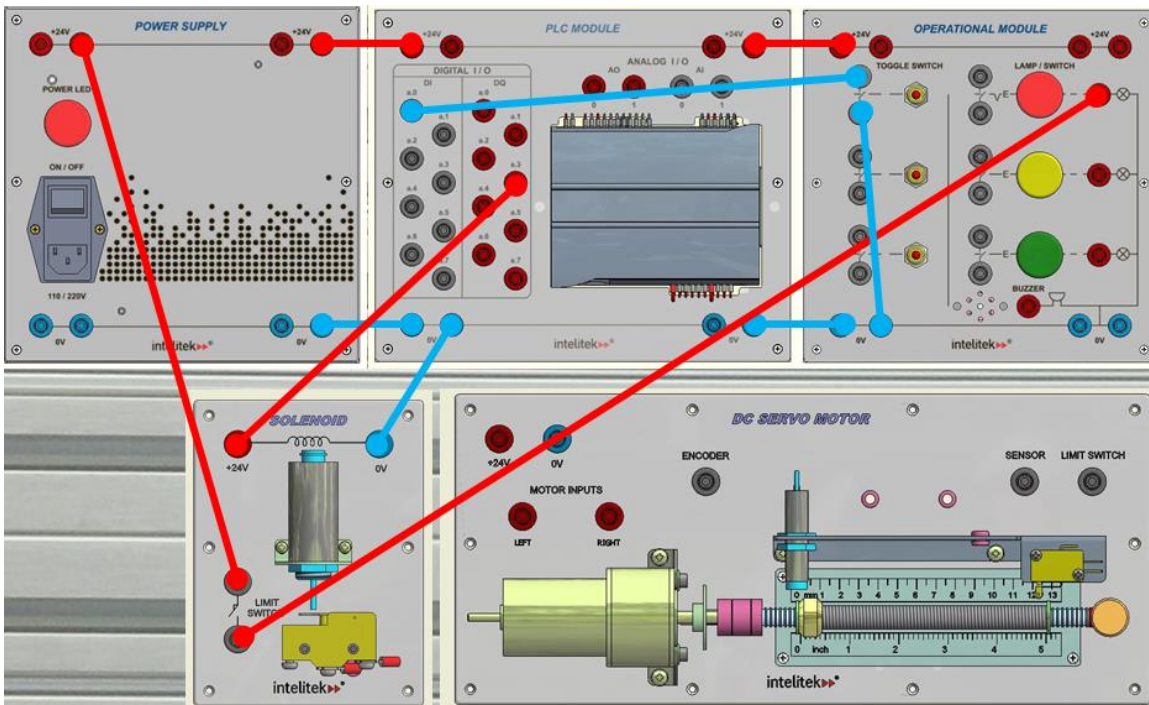

#### 4.1.4. Procedure

1. Mount all modules to the JMTS mounting panel.
2. Connect the power supply module to an appropriately-rated electrical outlet.
3. Turn on the power supply module.
4. Connect your computer to the PLC.
5. Program the PLC as described above in section 4.1.2.
6. Wire the modules as shown above in section 4.1.3.
7. Turn on the upper switch of the operational module. The solenoid extends and closes the limit switch. The red lamp is illuminated.
8. Turn off the upper switch. The solenoid contracts. The limit switch opens, cutting off power to the red lamp.

## 4.2. EXAMPLE 2: RUNNING THE MOTOR

In this application, turning on the operational panel’s upper switch causes the motor to drive the nut to the right. When the nut reaches the limit switch or if the middle switch is turned on, the motor stops running.

When the upper switch is turned off, turning on the middle switch causes the motor to drive the nut to the left. The motor turns off once the nut reaches the inductive sensor.

### 4.2.1. Requirements

- PLC1 Kit DC servo motor module
- Electrical connectors
- JMTS mounting panel
- MicroLogix 1100 PLC module or Siemens S7-1200 PLC module
- Computer with PLCMotion software (for the MicroLogix 1100 PLC module) or SIMATIC STEP 7 TIA Portal software (for the S7-1200 PLC module)
- Power supply module
- Operational module

### 4.2.2. Programming

Using PLCMotion (for Allen-Bradley) or TIA Portal (for Siemens), build the ladder diagram and tag the instructions for the I/Os of your controller as shown.

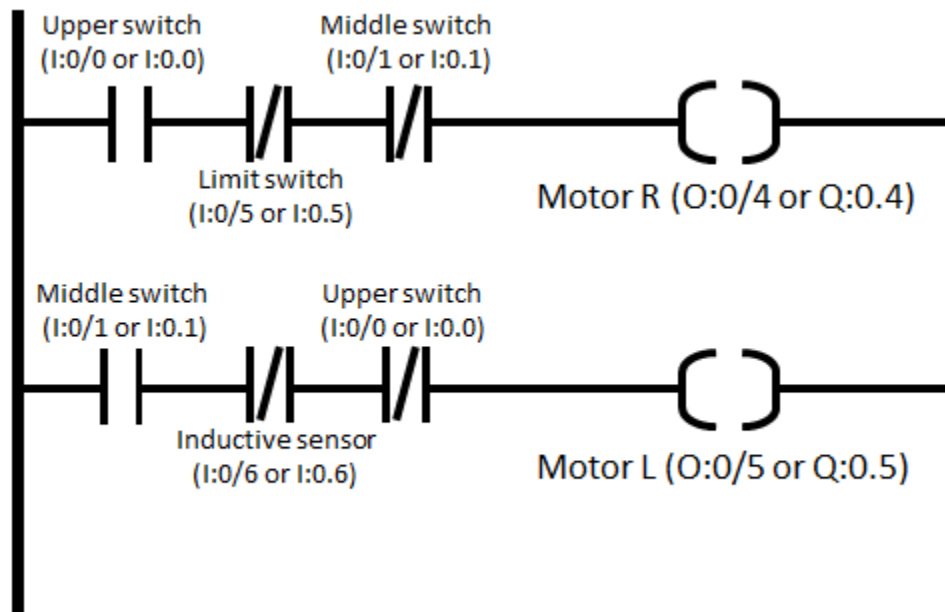



#### 4.2.4. Procedure

1. Mount all modules to the JMTS mounting panel.
2. Connect the power supply module to an appropriately-rated electrical outlet.
3. Turn on the power supply module.
4. Connect your computer to the PLC.
5. Program the PLC as described above in section 4.2.2.
6. Wire the modules as shown above in section 4.2.3.
7. Turn on the upper switch. The motor turns on. The nut moves to the right until it activates the limit switch. The motor turns off.
8. Turn off the upper switch.
9. Turn on the middle switch. The motor turns on. The nut moves to the left until it activates the inductive sensor. The motor turns off.