

## Accessory Installation Guide Shield Opener with Sensors

Accessory Name	Shield opener with sensors
Accessory P/N	011104
Applicable to	ProMill 8000

### 1 Additional Requirements

To complete this installation you will require:

1. Small blade screwdriver (2 to 2.5 mm)
2. M6 allen key

### 2 Unpacking Instructions

1. Remove the shield assembly and the pneumatic panel from the crate.



2. Verify that there are no loose parts in the crate.

### 3 Install the Shield Opener Assembly

1. Loosen the ten 7mm nuts around the right-side window to remove the acrylic window and its steel frame.

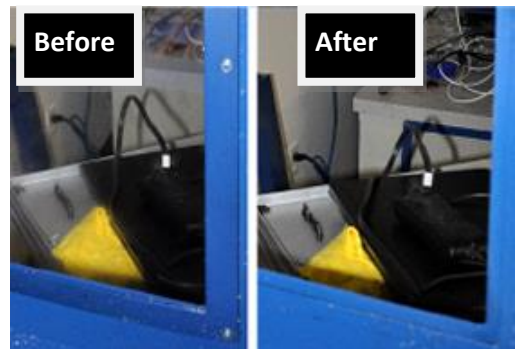
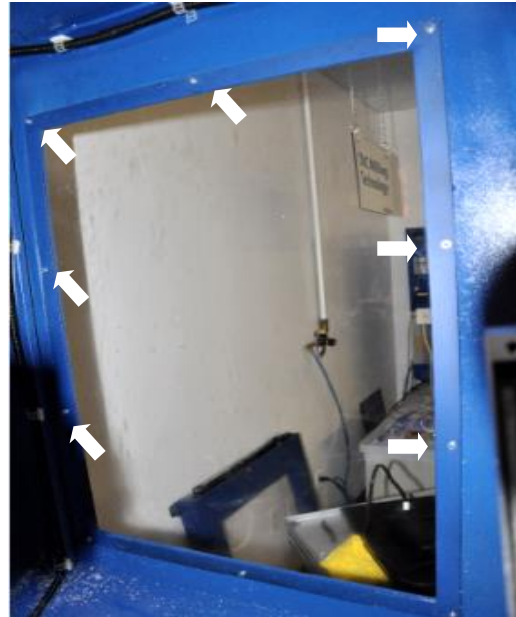

2. Remove the eight socket head screws located at the corners of the right side of the enclosure to remove the panel. Keep these screws for use later in this installation.



Once the panel is removed, the right side of the machine will look as shown below:



3. Attach the shield opener assembly to the enclosure using the eight socket head screws you removed previously.



#### 4 *Install the Pneumatic Panel*

1. Remove the four screws located to the right of the I/O panel.

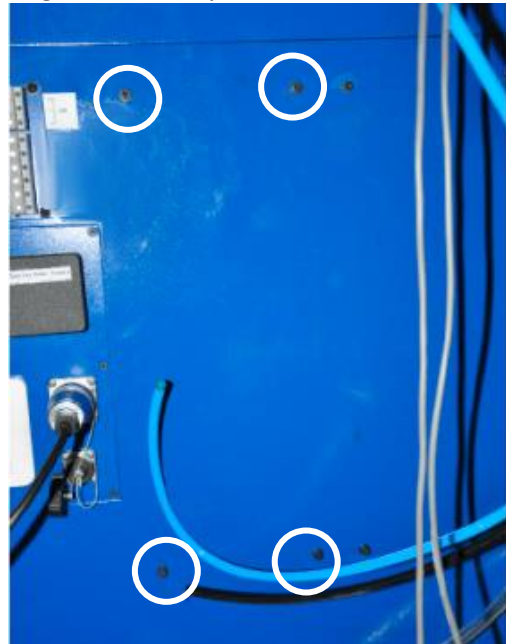

2. Mount the pneumatic panel on the enclosure using the screws you have just removed.



3. Connect the blue tubing from the shield opener to the blue output on the pneumatic panel, and the black tubing to the black output. You may cut the tubing to length using a tubing cutter.

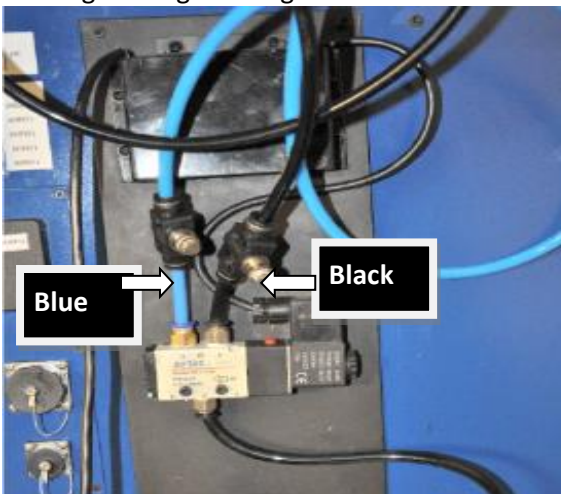

## 5 Connecting the Wiring

1. Connect the wires to the I/O panel at the side of the machine as outlined by the graphic and table below.

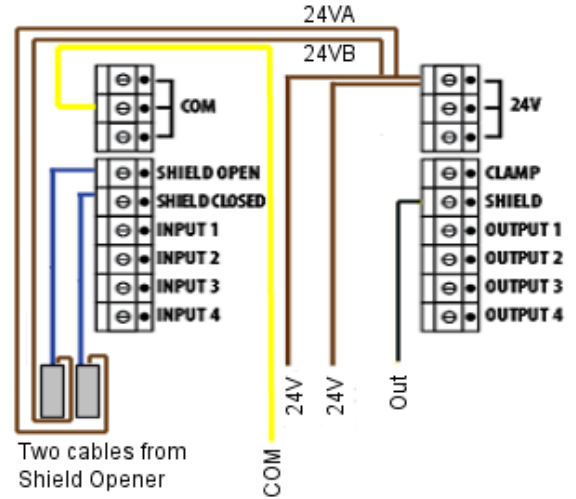

From Shield Opener Assembly	To Machine I/O Panel
24V A	24 V
24V B	24 V
OPEN	OUT
CLOSE	COM

2. Connect the blue input on the pneumatic panel to an air supply.



## 6 Configure the Software

1. Click **Start** → **All Programs** → **CNCBase for Intelitek CNC** → **CNC Configuration**.

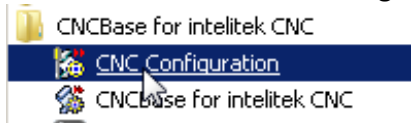

2. Click the **Options** tab.

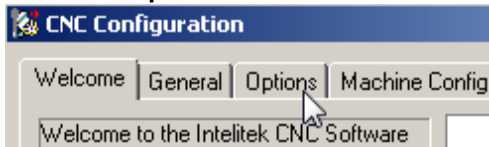

3. Click **Reinstall**.



4. Select **Shield Opener**.

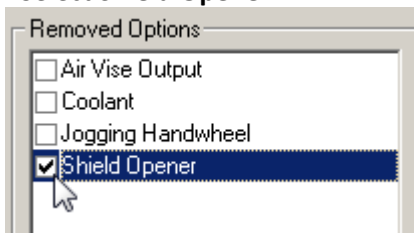

5. Click **Reinstall**.

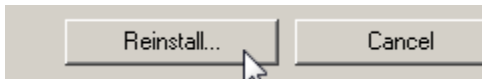

6. Click **OK** to close CNCBase.



Installation complete.