

## Accessory Installation Guide Pneumatic Chuck Kit for ProTurn 9000

Accessory Name	Pneumatic Chuck Kit
Accessory P/N	011110
Applicable to	ProTurn 9000

### 1 Additional Requirements

To complete this installation you also require:

1. Scissors or cutter
2. Plastic tubing cutter (for square cuts)
3. Small Philips head screwdriver
4. Spring clip remover
5. 14 mm Wrench
6. 55 – 62 mm Spanner wrench

### 2 Unpacking Instructions

1. Remove the pneumatic chuck assembly from the container.
  2. Clean off excess oil and grease.
  3. Cut the ties used to bind the air hoses.
- The complete part set is shown below.

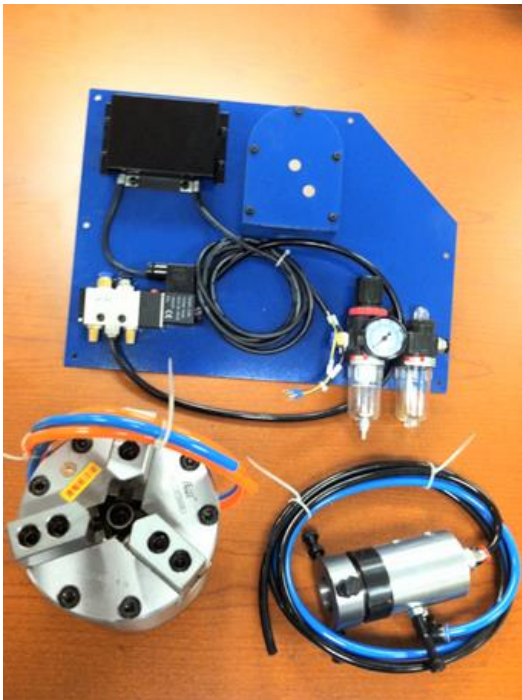

### 3 Remove the Original Chuck

1. Remove the side cover from the left side of the ProMill 9000 housing.

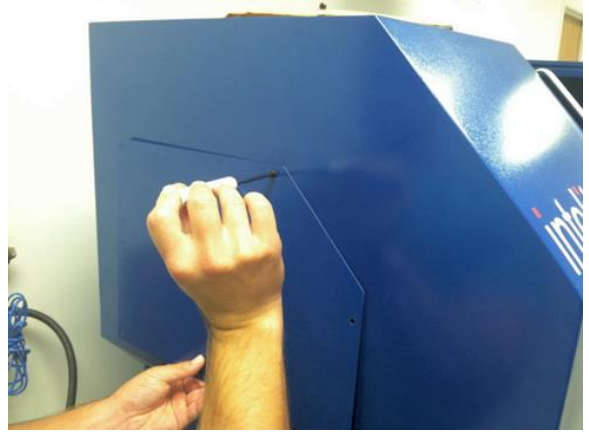

2. Loosen the three bolts on the chuck plate and remove the original chuck mounted on the lathe.

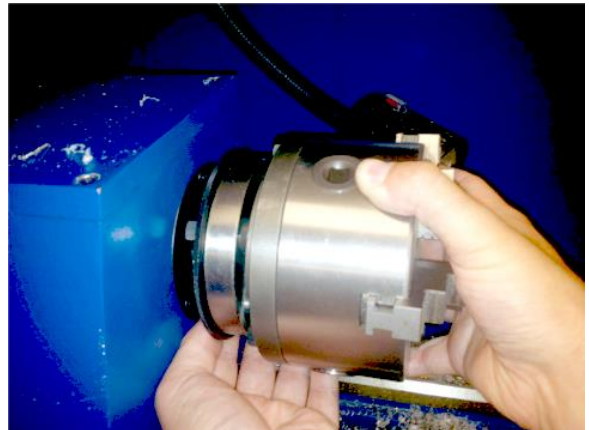

3. Hold the pneumatic chuck while pushing the orange and blue hoses through the lathe spindle head.



5. Remove the spring clip from the end of the spindle shaft and then remove the bushing (indicated) from the shaft.

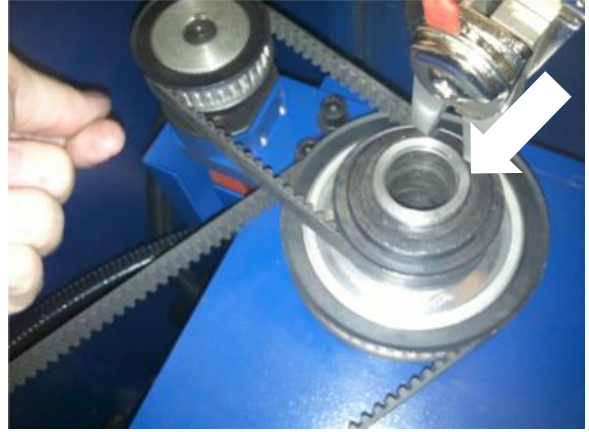

4. Mount the pneumatic chuck using the original three bolts. Hold the locking plate (indicated), apply pressure in the clockwise direction, and tighten the nuts securely.

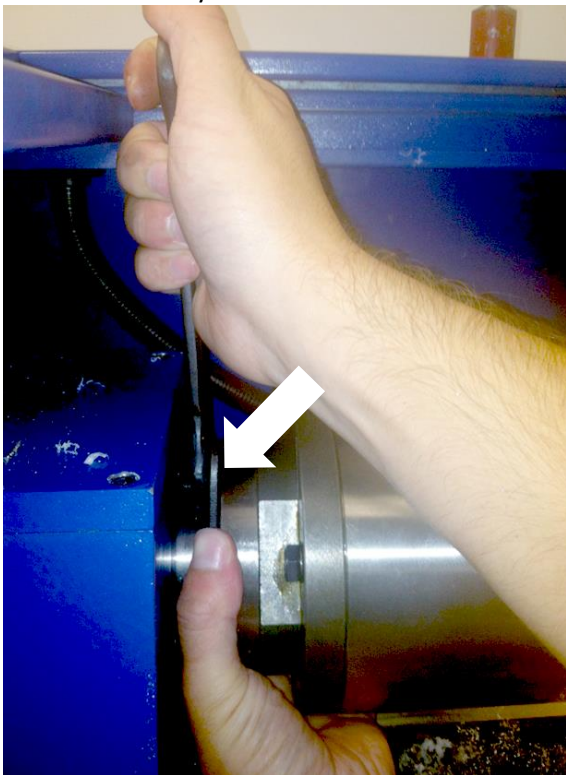

6. Remove the collar (indicated) from the pneumatic valve.

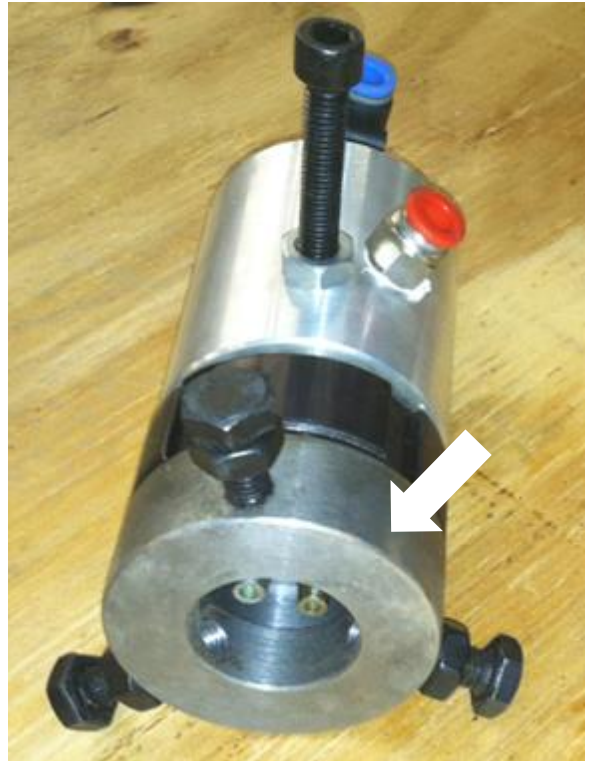

7. Cut the hoses to the appropriate length using the tubing cutter.



8. Place the collar over the tubing to mount on the spindle shaft.

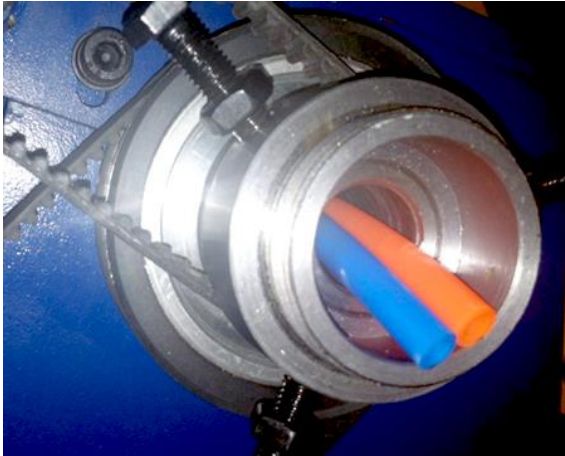

9. Press the pneumatic valve onto the hoses using a small quantity of soapy water or light pneumatic oil. Do not use an oil-based lubricant.



10. Tighten the bolts on the collar and ensure that the lock nuts are also tight.

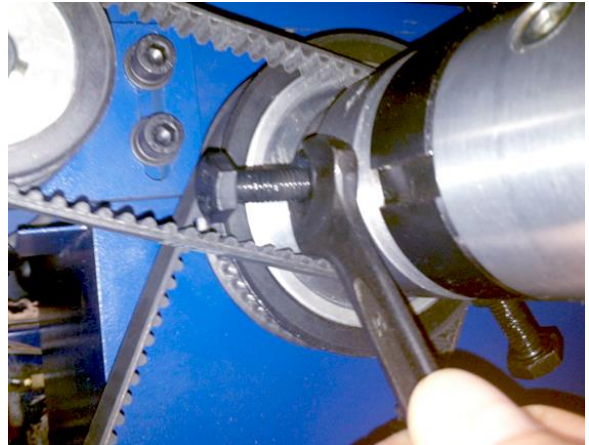



11. Brace the chuck against the bed as shown. This is necessary for the following step.



12. Use a spanner wrench to tighten the sleeve on the air valve. (The bracing set up in the previous step should prevent the spindle from turning during this operation.)



13. Attach the orange and blue air hoses to the pneumatic valve and pass their other ends through the new side cover (supplied in the kit) as shown.

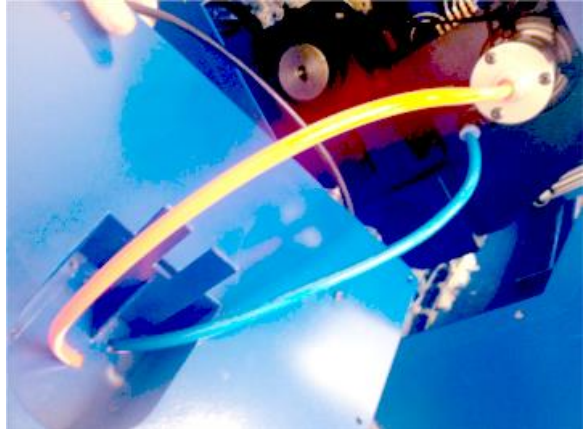

14. Mount the side cover on the lathe, making sure that the stud indicated in the picture slides between the two fingers on the side cover.

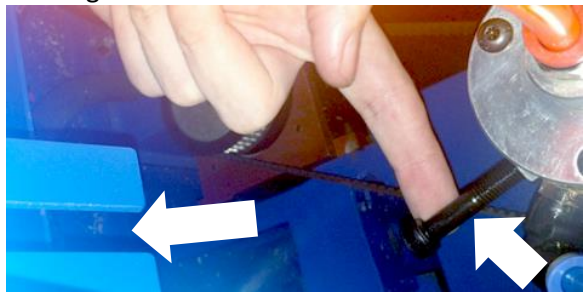

The picture below shows the stud in place.



- Secure the cover to the lathe using screws and a Phillips head screwdriver.
- Cut the hoses and insert into the solenoid valve.

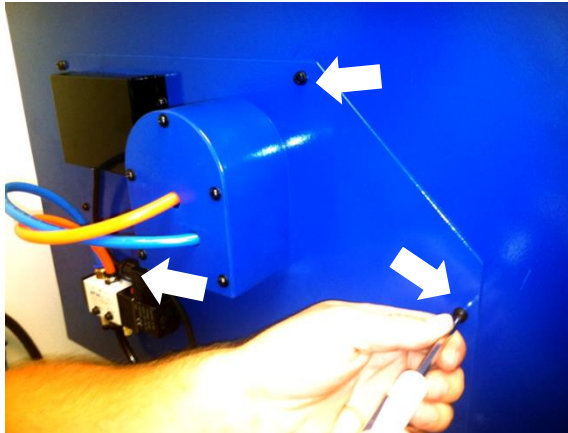

- Connect the blue line to the regulator and connect the air supply hose to your building's air supply.



#### 4 Connecting the Wiring

- Connect the wires to the I/O panel at the side of the machine as outlined in the graphic and table below.

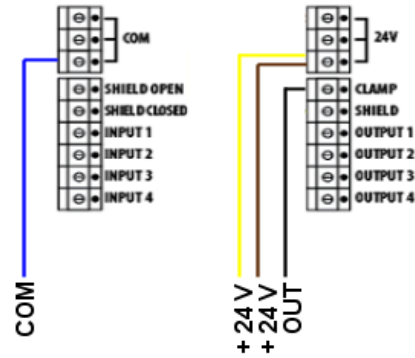

From Air Chuck Kit	To Machine I/O Panel
COM (Blue)	COM
+ 24 V (Yellow/Green)	24 V
+ 24 V (Brown)	24 V
OUT (Black)	CLAMP

#### 5 Configuring the Software

- Click **Start** → **All Programs** → **CNCBase for Intelitek CNC** → **CNC Configuration**.

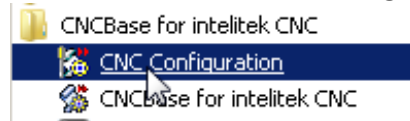

- Click the **Options** tab.

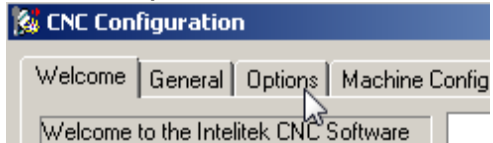

- Click **Reinstall**.



4. Select **Air Vise Output**.



5. Click **Reinstall**.



6. Click **OK** to close CNC Configuration.



## 6 Test the Installation

1. Click **Start** → **All Programs** → **CNCBase for Intelitek CNC** → **CNCBase for Intelitek CNC**.
2. Click and then re-click the Chuck icon in the side toolbar. Ensure that the air chuck opens and closes as expected.

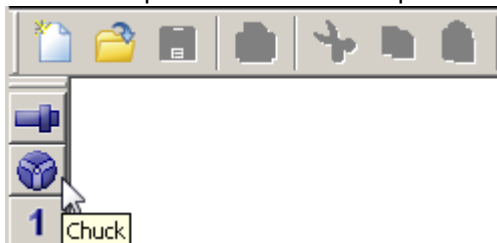

Installation complete.