

Accessory Installation Guide Dual Axis Vise Installation for Bench/ProMill

Accessory Name	Dual Axis Vise
Accessory P/N	011107
Applicable to	BenchMill 6000 ProMill 8000

1 Additional Requirements

To complete this installation you also require:

1. Scissors or cutter
2. #2 Phillips-head screwdriver
3. Plastic tubing cutter (for square cuts)
4. Dial indicator
5. 8 mm Allen wrench
6. 3 mm Allen wrench

2 Unpacking Instructions

1. Unpack and open all boxes in the crate.
2. Ensure that all boxes are emptied completely; additional parts may be revealed when packaging is removed.
3. Unwrap and wipe down all components. The complete part set is shown below.

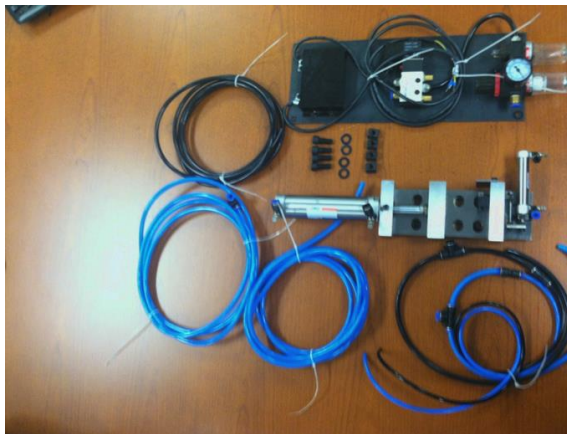

4. Ensure that all of the following parts are included:

- Dual axis vise
- Regulator panel
- 4 T-nuts
- 4 washers (not used)
- 4 socket head cap screws
- Blue and black hose assembly with T fittings installed
- Blue hose assembly with T fitting on end
- Long blue hose
- Long black hose

5. Cut the ties used to bind the air hoses.

3 Set the Vise

1. Choose a location on the mill table where you want the vise to be set. The location should be suitable for the milling of a workpiece.
2. Insert the four T-nuts into the appropriate slots at this location.
Note: If you want to mount other devices on the mill table, ensure enough space is left for them.

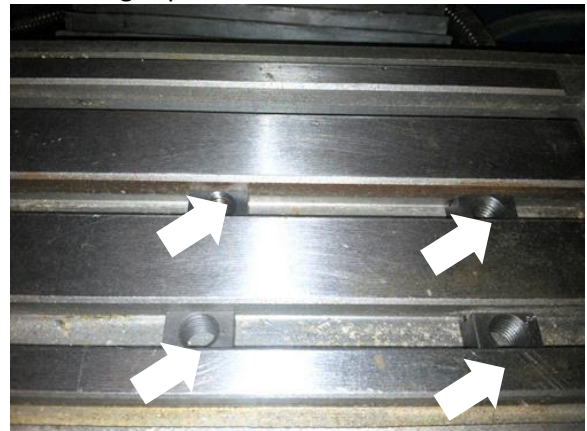

3. Install and tighten the socket head cap screws with an 8mm Allen wrench, leaving them loose enough so that the vise can be moved by hand with some pressure.



4 *Align and Secure the Vise*

1. Install a dial indicator in the machine's tool collet.
2. Run the dial indicator along the fixed jaw of the vise. Ensure that the fixed jaw of the vise is parallel to the Z-Axis.

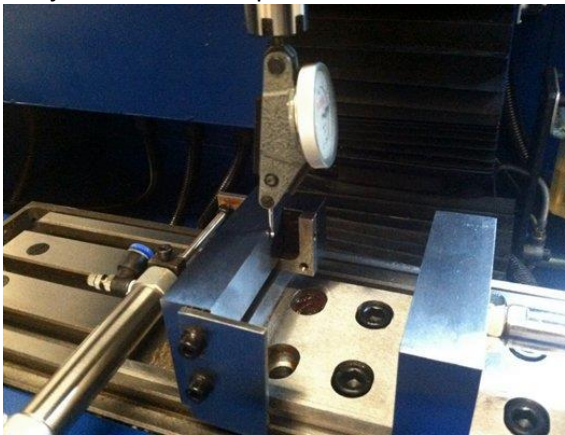

3. Tighten the four socket head cap screws to secure the vise to the table.

5 *Install the Hose Assemblies*

1. Install the blue and black air hose assemblies into the dual axis vise as shown below.

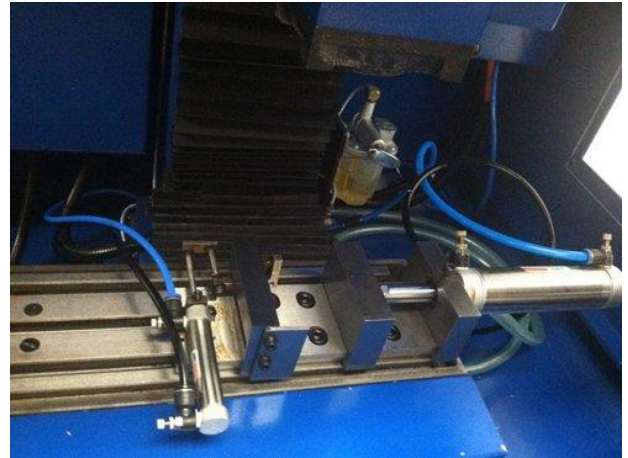

2. Route the hose assemblies around the back side of the column.
3. Insert the hoses into the color coded vise fittings.
4. Connect one end of each of the long blue and black air supply hoses to the T-fittings on the hose assemblies installed in the vise (previous step). Be sure to follow the color coding.



5. Install the regulator panel onto the side of the milling machine. To do so, use the 3 mm Allen wrench supplied in the machine tool box and the pre-installed screws on the side of the machine.



6. Cut the blue and black air hoses exiting the vise to the proper length, using the tubing cutter. The hoses should have a square cut.

7. Install the vise into the control valve as shown below.



8. Connect your building's air supply unit's hose to the regulator.

6 Connect the Electric Wires

1. Run the electric power wire under the milling machine.
2. Connect the wires to the I/O panel at the side of the machine as outlined in the graphic and table below.

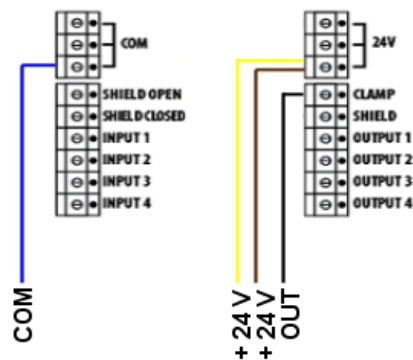

From Dual Axis Vise Assembly

COM (Blue)
 + 24 V (Yellow/Green)
 + 24 V (Brown)
 OUT (Black)

To Machine I/O Panel

COM
 24 V
 24 V
 CLAMP

7 Turn on the Air Supply

1. Turn on the air supply.
2. Set the regulator pressure to 80 psi.
3. Adjust the piston air valves on the vise (indicated below) to achieve the desired opening and closing speed of the pistons.

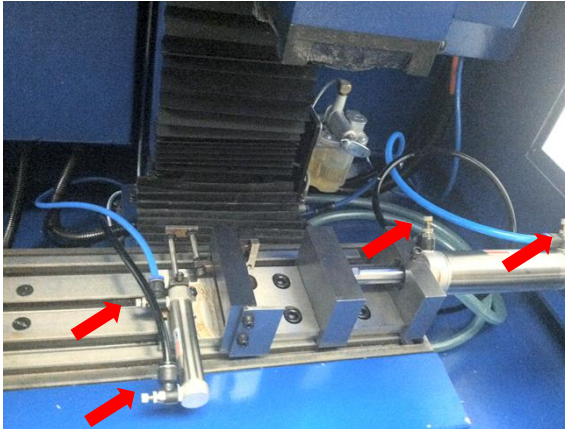

8 Configure the Software

1. Click **Start** → **All Programs** → **CNCBase for Intelitek CNC** → **CNC Configuration**.

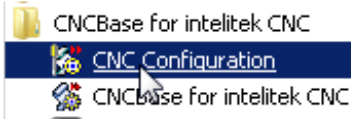

2. Click the **Options** tab.

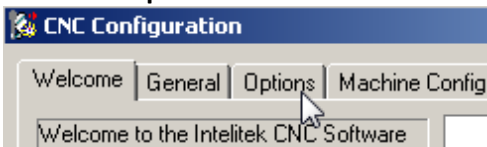

3. Click **Reinstall**.



4. Select **Air Vise Output**.

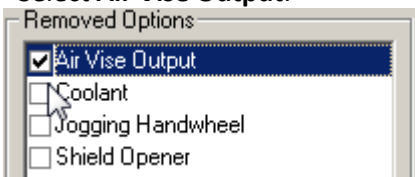

5. Click **Reinstall**.



6. Click **OK** to close CNCBase.



9 Verify Proper Vise Operation

1. Launch CNCBase from your Start menu.

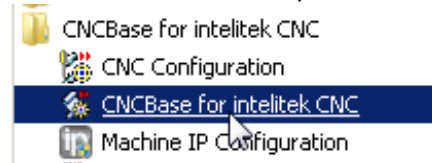

2. Click the Vise button on the Outputs toolbar. The vise should close.



Installation complete.