

**BENCHMAN VMC-4000**  
**Machining Center User's Guide**  
**For Windows**

**© 1997 Light Machines Corporation  
All Rights Reserved.**

The information contained in this guide was accurate at the time of its printing. Light Machines Corporation reserves the right to change specifications and operational performance of its products without notice. Any changes or corrections to the information contained in this publication will be incorporated in future issues.

This publication (34-7712-0001, March, 1997) corresponds to the VMC-4000 Machining Center package, including the Benchman 4000 control software.

Printed in U.S.A.

spectraCAM™ and BENCHMAN™ are trademarks of Light Machines Corporation.

All other register marks or trademarks are of their respective holders.

## **WARNING**

**The operation of rotating machinery should only be attempted by experienced, knowledgeable individuals!**

**Read the entire contents of this guide before running NC programs on the VMC-4000 Machining Center.**

**To avoid possible injury *always* observe the safety precautions described in this User's Guide.**





# Contents

## User's Guide

### Section A: Installation

---

Before You Start .....	A-2
Machine Requirements .....	A-2
Computer System Requirements .....	A-2
Getting Ready for Installation .....	A-3
Check Your Shipment .....	A-3
Register the BENCHMAN 4000 .....	A-3
Prepare Your Work Place .....	A-4
Unpack the BENCHMAN 4000 .....	A-4
Lifting the BENCHMAN 4000 .....	A-5
Forklift Method .....	A-5
Ring Method .....	A-5
Removal of the X Axis Cover .....	A-6
Reinstallation of the X Axis Cover .....	A-6
Hardware Installation .....	A-7
Installing the Motion Control Card in the PC .....	A-7
Opening the PC Chassis .....	A-7
Unpacking the Motion Control Card .....	A-8
Inserting the Motion Control Card .....	A-8
Setting the Hardware Address .....	A-10
Set DIP Switch Settings on Card and Install Card .....	A-14
Set Control Program Software to the New Address .....	A-14
Connecting the BENCHMAN 4000 .....	A-16
Connecting Power to the Hardware Components .....	A-18
Connecting the BENCHMAN 4000 to the Computer .....	A-18
Connecting Air Supplies .....	A-18
BENCHMAN VMC-4500 Differences .....	A-19

Software Installation .....	A-20
Installing the Control Program .....	A-20
Uninstalling the Control Program .....	A-21
The Setup Program .....	A-21
Technical Support .....	A-22
Before Calling .....	A-22
Warranty .....	A-22

## **Section B: System Hardware**

---

The BENCHMAN 4000 Machining Center .....	B-2
Features .....	B-2
BENCHMAN 4000 Components .....	B-3
The Main Machine Components .....	B-3
The Front Panel Components .....	B-4
Rear Panel Components .....	B-4
Intended Use of the Machining Center .....	B-5
The Process .....	B-5
Cutting Tools and Fixtures .....	B-5
Workpiece Materials .....	B-5
Misuse of the Machine .....	B-6
Operating Conditions .....	B-7
Work Area .....	B-7
Main AC Power Supply .....	B-7
Voltage .....	B-7
Frequency .....	B-7
Power Rating .....	B-7
Grounding .....	B-7
Environmental Conditions .....	B-8
Temperature .....	B-8
Humidity .....	B-8
Altitude .....	B-8
Shock .....	B-8
Vibration .....	B-8
Noise .....	B-8

<b>Maintaining the Machining Center .....</b>	<b>B-9</b>
Ballscrews .....	B-9
Bellows Covers .....	B-10
The Saddle .....	B-10
Lubrication .....	B-10
Adjustment .....	B-11
Spindle .....	B-12
Spindle Head .....	B-12
Spindle Motor .....	B-12
Checking for Spindle Shaft Play .....	B-12
Belts .....	B-13
Spindle Belt .....	B-13
Axis Drive Belts .....	B-13
<b>Maintaining the PC in a Shop Environment .....</b>	<b>B-14</b>
Caring for the Computer .....	B-14
Caring for Floppy Disks .....	B-15
<b>Factory Installed Options .....</b>	<b>B-16</b>
10,000 RPM Spindle .....	B-16
Digitizing Package .....	B-16
Air Vise .....	B-16
Automatic Tool Changer .....	B-17
Graphite Dust Collection System .....	B-17
4th Axis Control .....	B-17
Pneumatic Control .....	B-17
Flood Coolant .....	B-18
Filling the Sump .....	B-18
Flood Cooling Setup and Operation .....	B-18
Maintenance .....	B-19

## **Section C: Getting to know the Control Program**

---

<b>Starting the Control Program .....</b>	<b>C-2</b>
Starting the Control Program in Simulate Mode .....	C-2
<b>If You Need Help.....</b>	<b>C-3</b>
<b>Exploring the Control Program Screen .....</b>	<b>C-4</b>
Menu Bar .....	C-4

Standard Tool Bar .....	C-4
ATC Tool Bar .....	C-6
Outputs Tool Bar .....	C-7
Inputs Tool Bar .....	C-8
Edit Window .....	C-9
Status Bar .....	C-10
Position Readout .....	C-11
Machine Info Panel .....	C-11
Verify Window .....	C-12

## **Section D: Tutorial: Machining a Sample Part**

---

<b>Safely Running the Machining Center .....</b>	<b>D-2</b>
<b>Safety Rules .....</b>	<b>D-2</b>
Remove Adjusting Keys and Wrenches .....	D-2
Do Not Force a Tool .....	D-2
Use the Right Tool .....	D-2
Secure the Workpiece .....	D-2
Turn the Spindle By Hand Before Starting .....	D-2
Tighten All Holding, Locking and Driving Devices .....	D-2
<b>Making Emergency Stops .....</b>	<b>D-3</b>
Stopping with the Emergency Stop Button .....	D-3
Stopping with the Computer Keyboard .....	D-3
Stopping with a Limit Switch .....	D-4
<b>Running a Sample NC Program .....</b>	<b>D-5</b>
Open MILLONE.NC .....	D-5
<b>Adjust the Verify Settings .....</b>	<b>D-6</b>
Adjust the View .....	D-6
Adjust the Stock .....	D-7
<b>Define the Tool .....</b>	<b>D-8</b>
Add the Tool to the Library .....	D-8
Select the Tool for Verification .....	D-9
Verify MILLONE.NC .....	D-10
Dry Run the NC Program .....	D-11
Mount the Workpiece .....	D-13
Run the Program .....	D-13

# Reference Guide

## Section E: Control Program Reference

---

The BENCHMAN 4000 Interface .....	E-2
Using the Message Bar .....	E-3
Using Windows .....	E-3
Program Edit Windows .....	E-3
The Verify Window .....	E-4
The Machine Info Window .....	E-4
The Position Window .....	E-5
Using Toolbars .....	E-6
The Standard Toolbar .....	E-6
The ATC Control Toolbar .....	E-7
The Inputs Toolbar .....	E-7
The Outputs Toolbar .....	E-8
Using Panels .....	E-9
The Jog Control Panel .....	E-9
The Operator Panel .....	E-10
Using the Status Bar .....	E-11
Using the Menu Bar .....	E-12
File Menu .....	E-12
New Command .....	E-12
Open Command .....	E-13
Close Command .....	E-13
Save Command .....	E-14
Save As ... Command .....	E-14
Print Command .....	E-15
Print Setup Command .....	E-15
Opening a Recent Program .....	E-16
Exit Command .....	E-16
Edit Menu .....	E-17
Undo Command .....	E-17
Redo Command .....	E-18
Cut Command .....	E-18
Copy Command .....	E-18

Paste Command .....	E-18
Clear Command .....	E-19
Delete Line Command .....	E-19
Find Command .....	E-19
Replace Command .....	E-20
Goto Line Command .....	E-20
Renumber Command .....	E-21
Lock Command .....	E-23
Select Font Command .....	E-24
<b>View Menu .....</b>	<b>E-24</b>
Position Command .....	E-24
Machine Info Command .....	E-25
Jog Control Command .....	E-25
Operator Panel Command .....	E-25
Verify Window Command .....	E-25
Toolbars Command .....	E-25
<b>Program Menu .....</b>	<b>E-26</b>
Run/Continue Command .....	E-26
Verify Command .....	E-27
Estimate Runtime Command .....	E-28
Pause Command .....	E-29
Feedhold Command .....	E-29
Stop Command .....	E-29
<b>Tools Menu .....</b>	<b>E-30</b>
Setup Library Command .....	E-30
Setup Tool Wizard Command .....	E-32
Select Tool Command .....	E-32
Insert Tool From Command .....	E-33
Configure ATC Command .....	E-33
Operate ATC Command .....	E-34
Initialize Station Location ... Command .....	E-34
<b>Setup Menu .....</b>	<b>E-35</b>
Set Position Command .....	E-36
Zero Position Command .....	E-36
Jog Settings Command .....	E-37
Run Settings Command .....	E-38
Verify Settings Command .....	E-40
Verify Type Command .....	E-43

Set/Check Home Command .....	E-43
Goto Position Command .....	E-44
Units Command .....	E-44
Coordinate Systems Command .....	E-44
Offsets Command .....	E-46
Spindle Command .....	E-47
Backlash Command .....	E-48
Soft Limits Command .....	E-48
Preferences Command .....	E-49
<b>Window Menu .....</b>	<b>E-51</b>
Cascade Command .....	E-51
Tile Command .....	E-52
Arrange Icons Command .....	E-52
Window List Command .....	E-52
<b>Help Menu .....</b>	<b>E-52</b>
Help Command .....	E-52
Index Command .....	E-52
Using Help Command .....	E-53
Save Settings Command .....	E-53
Restore Settings Command .....	E-53
Tip of the Day Command .....	E-53
About BENCHMAN ... Command .....	E-53
<b>Selecting Commands .....</b>	<b>E-54</b>
Select a Command Using Pop-Up Menus .....	E-54
Program Edit Window Pop-up Menu .....	E-54
Position Window Pop-up Menu .....	E-56
Verify Window Pop-up Menu .....	E-56
Jog Control Panel Pop-up Menu .....	E-57
Select a Command Using Hot Keys .....	E-58
Select a Command Using Toolbars .....	E-59
<b>Positioning Screen Components .....</b>	<b>E-60</b>
Positioning Toolbars .....	E-60
Positioning Windows and Panels .....	E-60
Positioning Program Edit Windows .....	E-61
Saving the Window Positions .....	E-61
Docking and Floating Windows and Toolbars .....	E-62

Docked Screen Components .....	E-62
Floating Screen Components .....	E-62
<b>Using the Offset Table .....</b>	<b>E-63</b>
<b>Working in Simulation Mode .....</b>	<b>E-63</b>
<b>The Setup Program .....</b>	<b>E-64</b>
Welcome Panel .....	E-64
General Panel .....	E-65
Options Panel .....	E-66
Interface Card Panel .....	E-67

## **Section F: Basic CNC Programming**

---

<b>The Elements of an NC Part Program .....</b>	<b>F-2</b>
<b>Categories of NC Code .....</b>	<b>F-3</b>
Incremental Arc Center (%) .....	F-4
Absolute Arc Centers (\$) .....	F-4
Skip (\) and Optional Skip (/) .....	F-4
Compensation Offset Value (D Code) .....	F-5
Feed Rate (F Code) .....	F-6
Preparatory Codes (G Codes) .....	F-6
The Interpolation Group .....	F-7
The Units Group .....	F-7
The Plane Selection Group .....	F-7
The Wait Group .....	F-8
The Canned Cycle Group .....	F-9
The Programming Mode Group .....	F-9
The Preset Position Group .....	F-9
The Compensation Functions Group .....	F-10
The Coordinate System Group .....	F-11
The Polar Programming Group .....	F-11
Input Selection Number/Tool Length Offset (H Code) .....	F-12
X Axis Coordinate of Center Point (I Code) .....	F-12
Y Axis Coordinate of Center Point (J Code) .....	F-12
Z Axis Coordinate of Center Point (K Code) .....	F-13
Angle of Arc Resolution, Loop Counter (L Code) .....	F-13
Miscellaneous Codes (M Codes) .....	F-14



M22: Output Current Position to File .....	F-15
M99: Return from Subprogram, Goto .....	F-17
M105: Operator Message .....	F-17
Block Number (N Code) .....	F-18
Subprogram Block Number (O Code) .....	F-19
Subprogram Reference Number (P Code) .....	F-19
Peck Depth (Q Code) .....	F-19
Radius of Arc, Drilling Start Location (R Code) .....	F-20
Spindle Speed (S Code) .....	F-20
Tool Selection (T Code) .....	F-20
X Axis Coordinate (X or U Code) .....	F-21
Y Axis Coordinate (Y or V Code) .....	F-21
Z Axis Coordinate (Z or W Code) .....	F-21
Comment Codes .....	F-22
General Programming Suggestions .....	F-23

## Section G: More CNC Programming

---

Linear Interpolation Programming .....	G-2
Circular Interpolation Programming .....	G-3
Circular Interpolation on Other Planes .....	G-4
Helical Interpolation Programming .....	G-5
Rapid Traverse Programming .....	G-6
Canned Cycle Programming .....	G-7
Using G80 .....	G-7
Using G81 .....	G-8
Using G82 .....	G-9
Using G83 .....	G-9
Using G84 .....	G-10
Using G85 .....	G-11
Using G86 .....	G-11
Using G89 .....	G-12
Subprogram Programming .....	G-13
A Sample NC Subprogram .....	G-14

## Section H: Advanced CNC Programming

---

Using Polar Programming .....	H-2
Using the Homing Commands .....	H-3
Using G28 .....	H-3
Using G28 in an NC Program .....	H-3
Using G28 Before Setting Soft Limits .....	H-4
Using G27 .....	H-4
Using G29 .....	H-5
Using Cutter Compensation .....	H-6
Starting Cutter Compensation (G41/G42) .....	H-7
Cutter Compensation with IJK Vectors .....	H-10
Setting Cutter Compensation Offsets (D) .....	H-11
Changing Offset Values .....	H-12
Changing Offset Sides .....	H-13
Using Corner Offset Circular Interpolation (G39) .....	H-14
Canceling Cutter Compensation .....	H-15
Methods 1 and 4 .....	H-15
Methods 2 and 5 .....	H-16
Methods 3 and 6 .....	H-17
Using Scaling and Rotation Codes .....	H-18
Scaling .....	H-18
Uniform Scaling .....	H-18
Scaling Each Axis .....	H-19
Creating Mirror Images with Scaling .....	H-20
Rotation Codes .....	H-21
Combining Scaling and Rotation Codes .....	H-23
Multiple Tool Programming .....	H-24
Using Multiple Tool Codes .....	H-24
Establishing the Reference Tool .....	H-25
Establishing Tool Offsets .....	H-25
Testing Your Multiple Tool Program .....	H-26
Understanding Coordinate Systems .....	H-27
Machine Coordinates .....	H-27
Work Coordinates .....	H-27
Multiple Coordinate Systems .....	H-27

Using Tool Length Offset Codes .....	H-28
Using Tool Offset Adjust Codes .....	H-29
Using G45 .....	H-29
Using G46 .....	H-30
Using G48 .....	H-30
Using G47 .....	H-30

## **Section I: General Machining Information**

---

Feed Rate and Depth of Cut .....	I-2
Spindle Speeds .....	I-3
Feed Rate and Spindle Speed Selection .....	I-3
Tool Types .....	I-4
End Mills .....	I-4
Drills and Center Drills .....	I-5
Boring Tools .....	I-5
Sharpening Tools .....	I-5

## **Section J: Safe Machining Center Operation**

---

Safety Rules .....	J-2
Safety Checklist .....	J-6
Lista de Seguridad .....	J-7
Emergency Stops .....	J-8

## **Section K: G and M Codes Listed by Group**

---

G Codes by Group .....	K-2
M Codes by Group .....	K-5

## **Index**

---

**BENCHMAN VMC-4000**  
**Machining Center User's Guide**  
For Windows

# User's Guide

**Section A: Installation**

**Section B: System Hardware**

**Section C: Getting to know the Control Program**

**Section D: Tutorial: Machining a Sample Part**

# Reference Guide

**Section E: Control Program Reference**

**Section F: Basic CNC Programming**

**Section G: More CNC Programming**

**Section H: Advanced CNC Programming**

**Section I: General Machining Information**

**Section J: Safe Machining Center Operation**

**Section K: G and M Codes**

# Installation

**Before You Start**

**Getting Ready for Installation**

**Hardware Installation**

**BENCHMAN VMC-4500 Differences**

**Software Installation**

**Technical Support**

---

## Before You Start

Before you begin the BENCHMAN 4000 installation, read through the following list to be sure all the requirements have been met.

---

## Machine Requirements

The work place should be clean and uncluttered, with enough room to open and assemble the machining center and its components. You need 12.5 square feet (1.16 square meters) to operate the BENCHMAN 4000.

You should have a sturdy bench to put the machine and computer on.



### WARNING

**The machining center weighs approximately 600 lbs (273kg).  
Your bench must be able to safely support this weight.**

Keep in mind that when troubleshooting, you may need to check the circuit breakers on the rear panel of the machine.

Place the computer in an area where it will not be exposed to metal chips or cutting fluid.

Place the machining center within 6 feet of an appropriate electrical supply.

Finally, be sure you have met all of the required operating conditions.

---

## Computer System Requirements

The Control Program runs on a 586 /120MHz personal computer. The computer must have:

- ◆ Windows 95 or Windows NT 3.5 or higher
- ◆ 16MB RAM minimum for Windows 95 (24MB for best performance)
- ◆ 24MB RAM minimum for Windows NT
- ◆ A 3.5 in floppy drive
- ◆ A hard drive with at least 5MB of available space
- ◆ A full length ISA bus slot to install the Motion Control card
- ◆ A VGA graphics controller and monitor
- ◆ A Windows-compatible mouse



---

## Getting Ready for Installation

Before you connect and run your new BENCHMAN 4000, you should:

1. Check the shipment to make sure you received everything you need.
2. Register the BENCHMAN 4000 so it is covered by warranty.
3. Prepare a workspace for the BENCHMAN 4000.
4. Unpack and set up the BENCHMAN 4000.
5. Install the Motion Control Card into your computer.

When all of these procedures are complete, you can connect the BENCHMAN 4000 to your computer and install the Control Program.

---

## Check Your Shipment

The first thing you should do after receiving the BENCHMAN 4000 is inspect the packaging for any visible signs of damage. If there is damage to the outside of the packaging, contact the shipping company as well as Light Machines Customer Service Department at 800-221-2763 or 603-625-8600

---

## Register the BENCHMAN 4000

You'll find a registration card in the small box with the documentation and software disks. Clearly print all the requested information and return this card to Light Machines Corporation.

---

## Prepare Your Work Place

Make sure you have all the items on hand necessary to perform the installation. To install the BENCHMAN 4000, you must have ready:

- ◆ A sturdy bench on which you'll place the BENCHMAN 4000 and your computer. Placing the bench against a wall provides more stability. Make sure the wall has a 120 or 220 VAC, 15 amp polarized outlet.
- ◆ A personal computer running Windows 95 or Windows NT version 3.5 or greater. See page A-2 for a complete list of the necessary computer equipment.
- ◆ Your *PC Owner's Manual* or equivalent documentation.

---

### IMPORTANT!

---

Be sure to keep the pallet and all of the original cartons in which the VMC-4000 was shipped. Should any components need to be returned to the factory, pack them for shipping exactly as they were received.

Light Machines will not be responsible for any damage incurred during shipping when components are not returned in the original packing materials.

---

## Unpack the BENCHMAN 4000

1. Position the pallet near the bench on which you'll set the BENCHMAN 4000. The bench should be located against a wall for maximum support.
2. Remove the staples attaching the bottom of the cardboard container to the pallet.
3. Lift the cardboard container off of the pallet.
4. Inspect the BENCHMAN 4000 chassis for signs of visual damage such as a broken shield, a dent in the chassis or damaged cables.  
  
If any damage is noted, or if you find any discrepancies between the packing slip and the items received, call Light Machines' Customer Service Department (800-221-2763 or 603-625-8600).
5. Remove the two lag bolts from the 2x4 cross member holding the BENCHMAN 4000 on the pallet.

## Lifting the BENCHMAN 4000



### WARNING

The BENCHMAN 4000 weighs approximately 600 lbs (273 kg). Do not lift the machine by the safety shield or by the X axis extension box. Lifting the machine by methods other than those described here may damage the machine, or cause personal injury.

There are two ways to lift and move the BENCHMAN 4000. The base of the machine is designed so that a forklift can be used to lift it off of the pallet and place it on the benchtop. Or you may use the lifting ring attached to the top of the machine. The following are the proper lifting and moving procedures for the BENCHMAN 4000.

### Forklift Method

1. Remove the lag bolts holding the 2x4 cross member to the pallet, and remove the cross member.
2. Carefully guide the forks of the lift under the machining center.
3. Using the forklift, raise the machine off the pallet, and move the machine to the desired location.
4. Carefully lower the BENCHMAN 4000 to the benchtop.

### Ring Method

You should be aware that when you lift the BENCHMAN 4000 by the lifting ring, the machine will tilt forward approximately 20°. For this reason, **lift the machine slowly.**

1. Remove the lag bolts holding the 2x4 cross member to the pallet, and remove the cross member.
2. Attach a crane or sling to the lifting ring.
3. Lift the machine off of the pallet using the lifting ring. When you lift the machine, it will tilt forward 20°.
4. Guide the machine to its workplace.
5. Carefully lower the BENCHMAN 4000 to the benchtop.

---

## Removal of the X Axis Cover

If you are required to move the BENCHMAN 4000 through a narrow area such as a doorway, it will be necessary to remove the X axis cover. The following is the removal and reinstallation procedure. Please read through all the steps before removing the cover.

1. Remove the 8 button head cap screws on the outside of the enclosure that attach the X axis cover to the enclosure.
2. Reach under the outside of the cover and remove the nut from the PEM stud that attaches the X axis cover to the Y axis cover.
3. Remove the 9 button head cap screws on the inside of the enclosure that screw into the X axis cover. Be careful when removing these screws, they are the last item attaching the cover to the enclosure.
4. If the X axis cover does not come off after all the fasteners are removed, push down on the cover sharply. This will break the original silicone seal applied at the factory.

---

## Reinstallation of the X Axis Cover

1. Remove all remaining silicone from the X axis cover and the enclosure left over from the original seal.
2. Mount the front of the X axis cover onto the PEM stud coming out of the Y axis cover. Attach the X axis cover to the enclosure from the inside using the 9 button head cap screws that were removed.
3. Install the remaining 8 button head cap screws into the bottom of the X axis cover on the outside of the enclosure.
4. Replace the nut on the PEM stud on the inside of the cover.
5. Use the tube of DOW Corning 732 Silicone supplied with the machine, to reseal the X axis cover to the enclosure.
  - a) Partially remove each of the screws on the inside of the enclosure and apply a bead of silicone under the head of the screw. Tighten all the screws and remove any excess silicone. Apply a layer of silicone over all the PEM nuts on the inside of the enclosure.
  - b) Apply a bead of silicone along the seam between the enclosure and the X axis cover on the inside of the enclosure. Smooth the silicone out evenly, filling the entire seam. Remove any excess silicone.
  - c) Allow 24 hours for the silicone to cure before using the coolant option.

## Hardware Installation

The following paragraphs review the procedures for installing all the hardware components of the BENCHMAN 4000. Be sure that your computer system meets all of the requirements outlined on page A-2. It should also be set up according to the instructions in your PC owners manual.

The first step is to install the Motion Control Card in your personal computer.



### WARNING

**Do not connect power to the BENCHMAN 4000 or the computer until instructed to do so in the following procedures.**

### IMPORTANT

The Motion Control Card is factory set to operate in the address range reserved for Bisync cards on the PC I/O address map "03A0 hex". If another expansion card is already installed to operate at this address, or if your computer is connected to a network, you may need additional information. See page A-10, Setting the Hardware Address, for the correct procedures.



## Installing the Motion Control Card in the PC

The following paragraphs describe the procedure for installing the Motion Control Card in the chassis of your PC. You should have already set up your PC according to the instructions in your owner's manual. The Motion Control Card can be installed in any full-size slot designated for expansion card use. Refer to your computer owner's manual to determine particular expansion card restrictions.

### WARNING

**Do not plug the power cord from the PC chassis into an AC outlet until all installation procedures have been completed and the chassis cover has been closed.**

## Opening the PC Chassis

To install the Motion Control Card, you must remove the cover of the PC. Refer to the instructions supplied with your PC for details on removing the cover. Generally, the cover is secured by four screws through the rear panel; however, some PC's may have push latches, or screws in different locations.



#### **WARNING**

**Disconnect power from your PC before opening the chassis cover!  
Turn off the power switch and remove the power cord to assure that no electrical potential is present when the cover is removed.**

Set the cover aside and locate the slot where the card is to be mounted. Remove the blank slot cover (if any). This requires removing a screw at the top rail of the rear panel. You may choose to discard the cover, but save the screw for installing the Motion Control Card.

### **Unpacking the Motion Control Card**



#### **WARNING**

**The NextMove Card is highly sensitive to static discharge. To avoid possible damage to the card, wear the enclosed wrist strap and grounding wire when removing the card from its packaging.**

The card is shipped inside an anti-static envelope. Handle the card by the edges, being careful not to create any static discharge. Grounding yourself with a static discharge wrist strap or working on a grounded surface is suggested. Slide the card out of the envelope and inspect it for signs of damage, such as bent or broken components or a warped circuit card. If damage is noted, contact Light Machines Corporation immediately.

## Inserting the Motion Control Card

### IMPORTANT!

If, after installing the Motion Control Card, the software fails to recognize the card, you may need to reset the I/O address. See page A-10 for I/O address information.

Before installing the card into the computer, verify that the following jumpers are installed or removed. Use the following graphic to verify the location of the jumpers on the card. See page A-10 for information on setting S1.

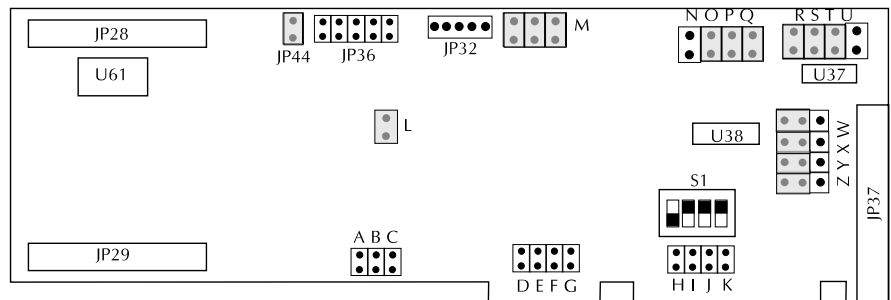

Position	State	Position	State
A,B,C,	Removed	L	Installed (white)
D,E,F,G,	Removed	M (3)	Installed
I,J,K	Removed	O,P,Q	Installed
N	Removed	R,S,T	Installed
U	Removed	JP44	Installed
H	Usually Removed		
	used for Switch Pack		
JP32, JP36	Removed		

The following procedures describe how to insert and secure the Motion Control Card in the computer.

1. Grasp the Motion Control Card at the front and back.
2. Position the card above the bus connector at the chosen slot. The interface connector on the end of the card should face the rear panel of the computer chassis.
3. Slide the card into the bus slot. The connector on the card should protrude from the rear panel of the computer. Carefully wiggle the card back and forth to assure its tightness in the bus slot. Components on the Motion Control Card should not touch adjacent cards or other components.
4. Secure the card to the top rail of the rear panel with the screw you saved when removing the blank slot cover.
5. Make note of which slot the Motion Control Card is plugged into.

## Setting the Hardware Address

If you are having problems getting the software to recognize the NextMove motion card, you may have an address conflict. Address conflicts result when there is additional hardware using the same (default) I/O address as the NextMove Motion Card. The factory I/O address setting is 0320-0322. The following procedure should be used to reconfigure the hardware address.

---

### CAUTION

---

The Motion Control Card is highly sensitive to static. Use the enclosed anti-static wrist strap or other static safety precautions when handling the card.

1. Power off the Computer and remove the NextMove motion card. It is necessary to remove the card in order to reset DIP switch settings. You may also be unable to reserve system resources while the card is still in the system.
2. Power on your computer and allow Windows 95 to start up.
3. Click on the Start button. The Windows 95 Start Menu appears.
4. Click on the Settings option. The Settings sub-menu appears.
5. Click on the Control Panel option listed in the Settings sub-menu. The Control Panel window will appear on the desktop.

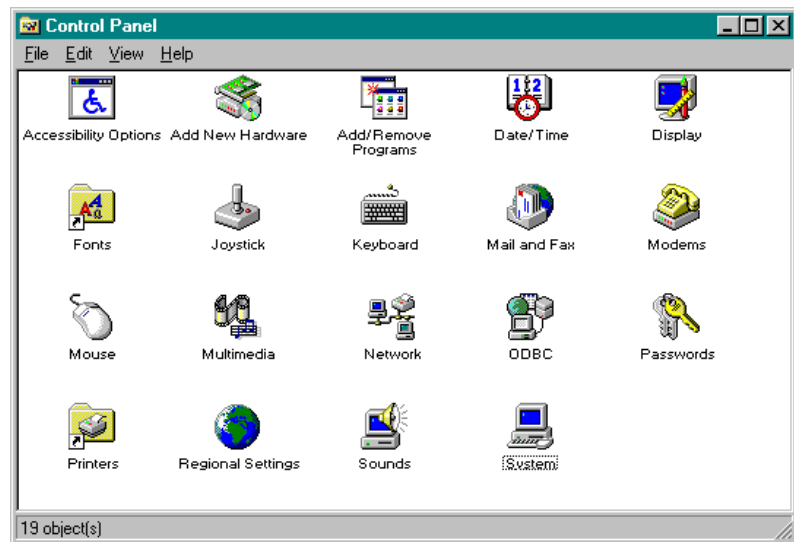



6. Click on System to open the System Properties window. Select the Device Manager tab. Your screen will look similar to this.

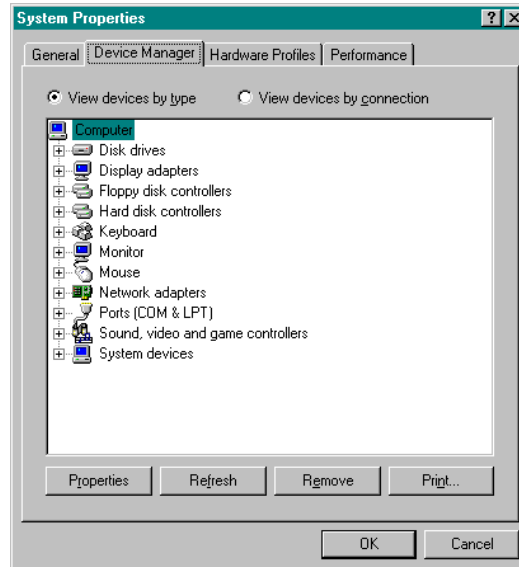

7. To reserve system resources, double click on Computer to open the Computer Properties dialog box. Select the Reserve Properties tab, then select the Input/Output (I/O) radio button.

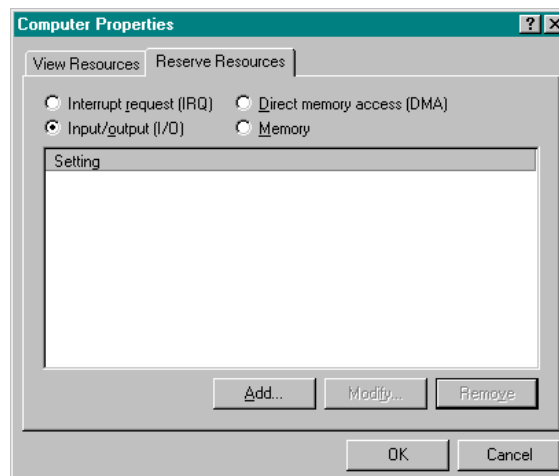

- Select the Add... button to define a reserved system resource. The Edit Resource Setting dialog box appears. Enter the Start Value and the End Value for the Input/Output Range you wish to reserve for the Motion Control Card. The Start and End values can be determined by using the following table.

DIP Switch Settings	Start Value	End Value
ON, ON , ON, ON	300	302
ON, ON, ON, OFF	304	306
ON, ON, OFF, ON	308	30A
ON, ON, OFF, OFF	30C	30E
ON, OFF, ON, ON	310	312
ON, OFF, ON, OFF	314	316
ON, OFF, OFF, ON	318	31A
ON, OFF, OFF, OFF	31C	31E
OFF, ON, ON, ON	320	322
OFF, ON, ON, OFF	324	326
OFF, ON, OFF, ON	328	32A
OFF, ON, OFF, OFF	32C	32E
OFF, OFF, ON, ON	330	332
OFF, OFF, ON, OFF	334	336
OFF, OFF, OFF, ON	338	33A
OFF, OFF, OFF, OFF	33C	33E

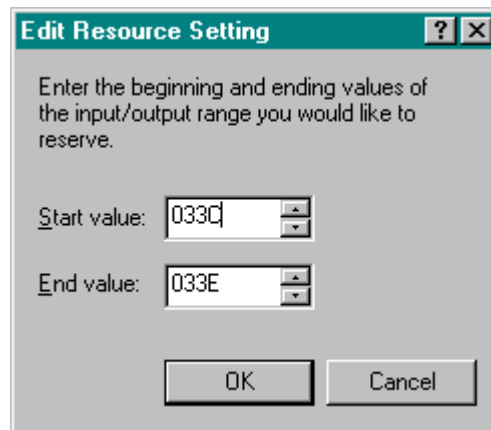

- In the above example, the address range from 033C to 033E is being reserved for the NextMove card. Select OK to close the Edit Resource Setting Dialog box. This range has now been reserved by the system. Note that if the range you have selected is already in use, an error will be posted, and you will have to select a different range.

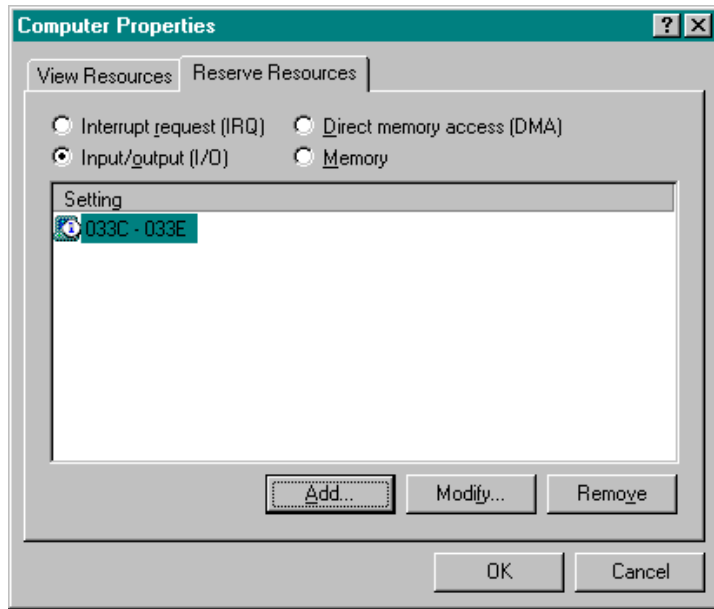

10. Select OK to close the Computer Properties dialog box. A prompt will appear verifying that the system resources have been modified.

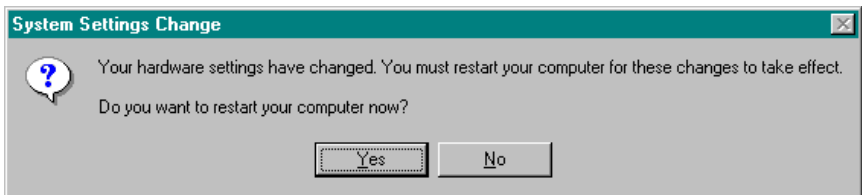

11. Select No. The computer will have to be powered down before installing the NextMove card. If you select Yes, the computer will automatically restart and you will have to power down again before inserting the card. Select OK to close the System Properties dialog box.
12. Manually power down the system by selecting the Start button, and then selecting Shut Down.... When Windows has shut down, you may power off the system.

## Set DIP Switch Settings on Card and Install Card

Once you have chosen a valid address in the software, the address on the card must be set to match. Be sure to observe all static discharge procedures when handling the motion control card in order to prevent static damage.

1. Locate the S1 DIP switch block which is located just above the HIJK jumper pins. Using the list on page A-12, set the DIP switches to match the settings for the address that you have reserved for the card.
2. Insert the card into the computer, making sure that the card is fully seated in the expansion bus. Because this is a full-length card, you should double check to ensure that the card is seated.
3. Replace all covers and power up the computer.

## Set Control Program Software to the New Address

Once the card has been set to a free address, the Control Program software must be set to recognize the new address.

1. Select Set up from the BENCHMAN folder. The Setup utility appears.

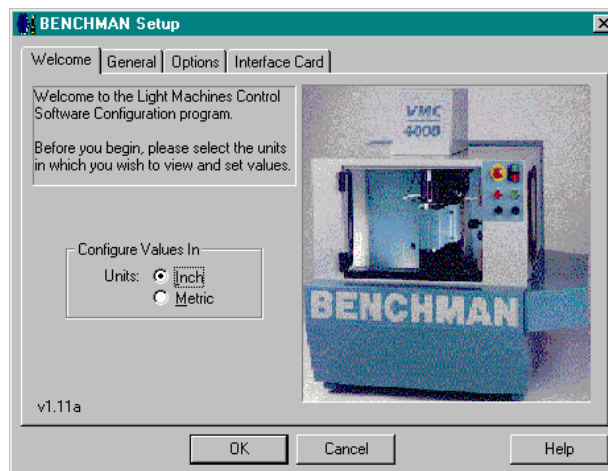

2. Select the Interface Card tab and use the up/down arrow keys to scroll to the interface card address settings. Note that the DIP switch settings on the screen will be updated as well.
3. Once the Interface Address is set in the software, select OK to close the Setup utility. You may now run the BENCHMAN software.

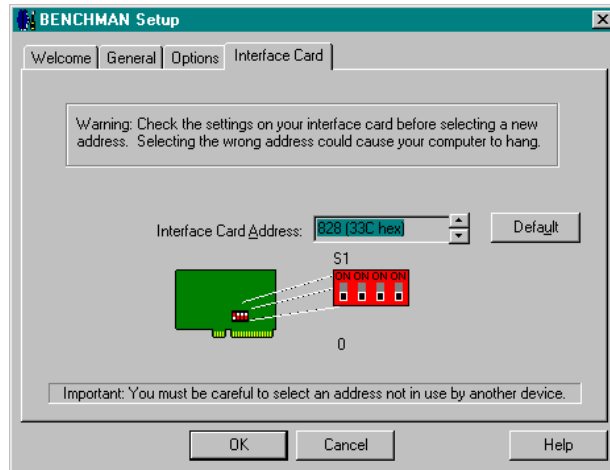

---

## CAUTION

---

Try to keep the AC power cords away from the interface cable. The power cords can create noise problems with the signal lines in the interface cable.

## Connecting the BENCHMAN 4000

After installing the Motion Control Card in the computer and verifying its operation, the BENCHMAN 4000 connections can be made. The following cables and lines must be connected:

- ◆ 100 pin interface cable between the computer and machining center;
- ◆ ATC air supply (if ATC is installed);
- ◆ Air curtain air line if you are installing a VMC-4500;
- ◆ BENCHMAN 4000 power cord;
- ◆ Computer power cord.

The connection diagram on the following page is provided as a visual aid.



### WARNING

**Do not connect power to the BENCHMAN 4000 or the computer until instructed to do so in the following procedures.**

**Never connect or disconnect the cables with the power on! This will cause damage to the components.**

**Operate the BENCHMAN 4000 with all cables firmly secured.**

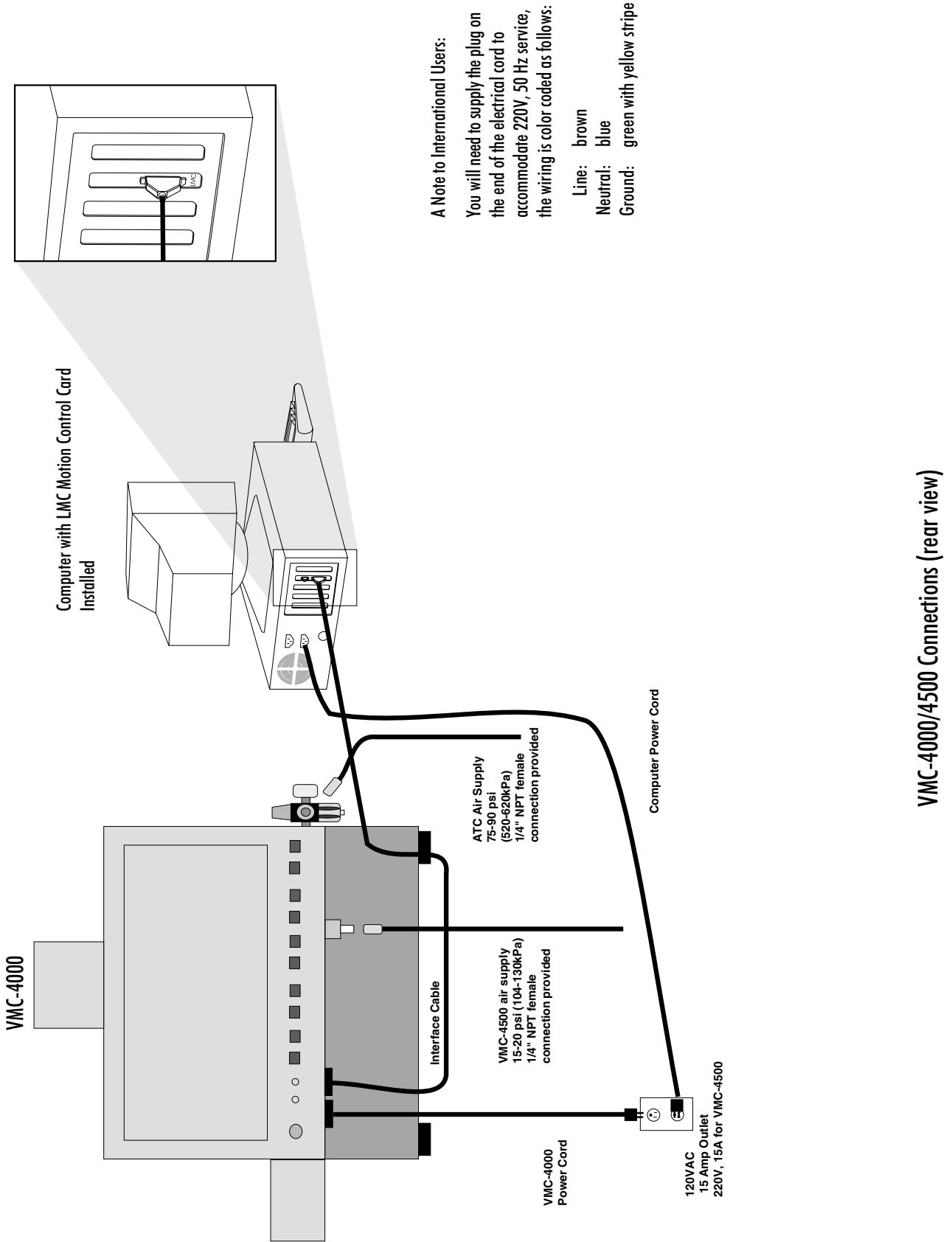

---

### CAUTION

---

The Interface cable connector is very fragile. The pins may be easily bent, causing a bad connection and potentially damaging the machine or the computer. Use care when attaching or handling the cable connector.

---

### IMPORTANT!

---

It is possible to attach the cable connector to the computer upside down, and damaging the pins. Pay close attention to the connector orientation.

## Connecting the BENCHMAN 4000 to the Computer

There is a single 100-pin cable that connects the machining center to the computer. Carefully plug this cable into the Motion Control Card that you installed in your computer. Be sure the cable is installed correctly. It is possible to make this connection **backwards!** Tighten the finger screws on the cable to be sure that it is firmly attached. A loose or marginal connection can cause problems operating the machining center.

## Connecting Air Supplies

If your BENCHMAN 4000 is equipped with an Automatic Tool Changer, you need to connect an air line to the Regulator on the left rear corner of the machine. The line must supply 75-90 psi to operate the ATC.

Although the ATC is not available with the VMC-4500, there is an air line that must be connected at the rear of the machine. This line must provide 15-20 psi minimum (or 104-130 kPa) for the Spindle Air Curtain. The air curtain is a pressurized area around the VMC-4500 spindle head, which helps prevent moisture and dirt from entering the spindle motor bearings and causing premature wear. The location of the 1/4" NPT female connector is shown in the diagram below.

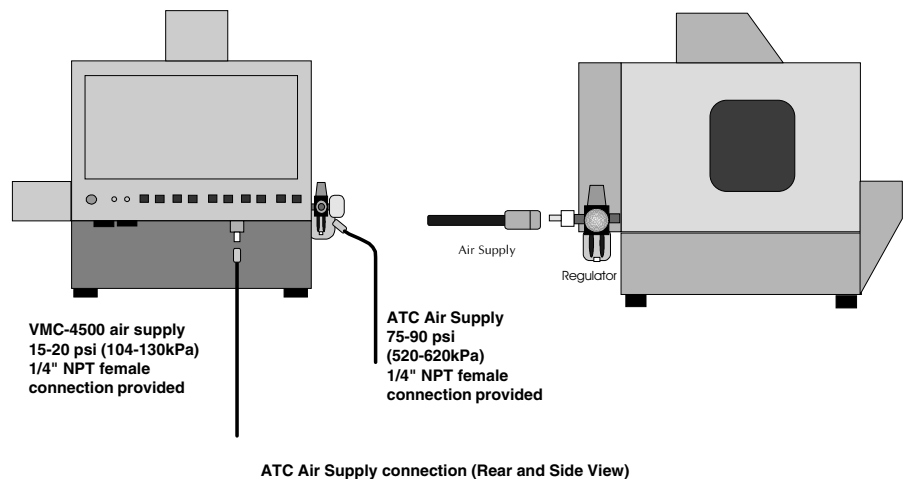

## Connecting Power to the Hardware Components

After securing the connections between the BENCHMAN 4000 and the computer, plug in the main power cords for each. Both the BENCHMAN 4000 and the computer must be plugged into a grounded 120 VAC, 60Hz, 15A, polarized outlet (220V, 50Hz for international customers). See the diagram on the previous page.



## BENCHMAN VMC-4500 Differences

If you have purchased a VMC-4500, you should know that there are only a few differences in operation from the BENCHMAN 4000.

- ◆ To achieve higher spindle speeds, the VMC-4500 uses a 1 hp high frequency induction motor. Before running at maximum speed on the VMC-4500, it is important that you run the spindle for a few minutes at 20,000 RPM to allow the bearings to warm up.
- ◆ A 220 VAC, 15 Amp outlet is required for the VMC-4500.
- ◆ Flood Coolant is not available on the VMC-4500. There should not be any fluids in the enclosure of the VMC-4500. Moisture will damage the spindle motor.
- ◆ Although the ATC is not available with the VMC-4500, there is an air line that **must** be connected at the rear of the machine. This line must provide 15-20 psi minimum (or 104-130 kPa) for the Spindle Air Curtain. The air curtain is a pressurized area around the VMC-4500 spindle head, which helps prevent moisture and dirt from entering the spindle motor bearings and causing premature wear. The location of the 1/4" NPT female connector is show in the Connection Diagram on the previous page.
- ◆ During the software installation, you may be prompted to specify the type of BENCHMAN product, and the spindle speed.

---

## CAUTION

---

The master disks are shipped write-protected (3.5 disks have the write-protect window open) to prevent accidental destruction of the software. *Never* remove the write protection! Create and use a working copy of the disks. Always store disks in a safe place away from heat, sunlight, static and magnetic sources.

---

## CAUTION

---

Make sure you read all the safety instructions in this guide before you attempt to run the Control Program with the VMC-4000 for the first time.

---

# Software Installation

The Control Program is shipped on 3.5", 1.4MB disks. The Control Program must be installed on a hard drive running either Windows 95, or Windows NT version 3.5 (or higher). You must have at least 5 MB of free space on your hard drive to perform this installation. See page A-2 for a complete list of computer requirements.

---

## Installing the Control Program

The Control Program must be installed on the hard drive on your computer. The following instructions assume that your hard drive is drive C, and your floppy drive is drive A.

1. Turn on the computer. Wait for it to go through its internal checks and for it to complete the start up process.
2. When your Windows desktop appears, insert the disk in the computer floppy drive.
3. Using the Windows Explorer, (Start Menu>Programs>Windows Explorer) open the floppy drive.

Note: If you are installing on Windows NT, use either the File Manager to access the floppy drive, or select Run from the Program Manager.

4. Double click on Install to start the installation.
5. The Welcome screen appears warning you to exit all other running programs. If no other programs are running, click Next.
6. The next screen is the destination directory for the Control Program. If you would like to install the control program in an alternate directory, click on Browse. Otherwise, click Next.
7. A window showing the progress of the installation will appear, and when ready, will prompt you to install the second disk. After the installation is complete, a message will appear asking if you would like to view the Readme file. It is suggested that you read this file. It contains important information about the software and the machine that may not be included in the manual.
8. After reading the Readme file, remove the disk from the floppy drive. Power on the machine, and then launch the Control Program by double clicking the BENCHMAN icon. You have the option of dragging the shortcut icon onto your desktop from the open BENCHMAN folder, or selecting the Start Menu> Programs> Benchman> BENCHMAN.

**Note:** Using the Uninstall program will not delete any NC files that you may have created or used with the software.

---

## Uninstalling the Control Program

In the event you need to remove the Control Program from your hard drive, there is an uninstall program included on the software disks. This uninstall program is part of the Control Program and was copied onto your hard drive during the installation.

To uninstall the Control Program software, select Start Menu> Programs> BENCHMAN> Remove BENCHMAN. A message appears asking if you are sure you want to remove the program and all its files. Click on Yes to uninstall, or No to exit the uninstall program.

---

## The Setup Program

The Setup Program allows you to select a number of program and hardware defaults, as well as configure the options installed on the machine. To access the Setup Program, you must exit the Control Program. Then select the Start Menu> Programs> BENCHMAN> Setup. The program will start and you will see the Welcome screen. You may choose from the file tabs to view the defaults for each category.

**The Setup Program provides defaults under the following categories:**

- ◆ Welcome
- ◆ General
- ◆ Options
- ◆ Interface Card

During the software installation, the Setup window opens automatically so that you can select the options installed on your machine. You may need to access the Setup Program again to remove options or to reset other defaults. See Section E: Setup Program for detailed information about the program.

---

## Technical Support

Should you require technical assistance, you should contact your local Light Machines dealer. If you are unable to resolve your problem through your local dealer, free technical support is available by phone, fax, or email from 8:15 A.M. to 5:00 P.M. EST.

---

### Before Calling

Make sure you have the following information gathered before contacting our Technical Support group.

- ◆ The product serial number.
- ◆ The name of the owner of the product.
- ◆ The specifications of your computer (e.g. hard drive size, clock speed, etc.).
- ◆ Notes on any Control Program error messages.

When you call, make sure you have access to both your BENCHMAN 4000 and your computer. This will allow our technical support representatives to *walk through* the problem with you. Our technical support numbers are:

U. S.	(800) 221-2763
Canada	(800) 637-4829
Fax	(603) 625-2137
email	support@lmc corp.com

---

### Warranty

Light Machines' products (excluding software) carry a one-year limited warranty from date of purchase, as outlined in the Terms and Conditions of Sale. If you need to return a product, call Light Machines and a Technical Support representative will issue you a Return Materials Authorization number (RMA). You must write the RMA and your return address on the outside of the product carton or crate. Failure to do so can result in a delay in the return of your product.

# System Hardware

The BENCHMAN 4000 Machining Center

BENCHMAN Components

Intended Use of the Machining Center

Misuse of the Machine

Operating Conditions

Environmental Conditions

Maintaining the Machining Center

Maintaining the PC in a Shop Environment

Factory Installed Options

---

## The BENCHMAN 4000 Machining Center

The BENCHMAN 4000 is designed to be the ultimate benchtop manufacturing solution. It is run directly from your personal computer, and by utilizing the optional Light Machines' spectraCAM software, you can design and machine parts in plastics, aluminum, steel, and graphite all from one operator station.

There are 2 models in the BENCHMAN 4000 family. The VMC-4000 comes with a 5000 RPM or optional 10,000 RPM spindle; and the VMC-4500, which comes with a 39,000 RPM spindle.

The BENCHMAN 4000 Machining Center is shipped fully assembled, and is easy to install. Complete instructions for installing the machining center, as well as software installation instructions, are included in Section A of this User's Guide.

---

### Features

Some of the BENCHMAN 4000 features include:

- ◆ A one horsepower brushless DC spindle motor (1 hp high frequency induction motor for the VMC-4500)
- ◆ An R8 industry-standard spindle taper (The VMC-4500 uses an ER-16)
- ◆ Computer controlled spindle speeds up to 5000 RPM (10,000 optional) for the VMC-4000, and up to 39,000 RPM for the VMC-4500
- ◆ Rapid traverse rates up to 200 ipm
- ◆ EIA RS-274D standard G&M code programming
- ◆ Multiple tool programming
- ◆ Feed rate and spindle speed override functions
- ◆ A built-in full-screen NC program editor
- ◆ An on-line help utility
- ◆ Simultaneous or simulated, solid or centerline graphic tool path verification

---

## BENCHMAN 4000 Components

There are, of course, more components on the BENCHMAN 4000 than those shown here, but to begin, you need only be concerned with the major components.

---

### The Main Machine Components

The Safety Shield encloses the milling area to help protect the operator from flying chips. An electro-mechanical Safety Interlock Switch prevents the machine from operating with the door open.

The X, Y, and Z motion of the machine is performed by DC servo drive motors on each axis. There are also Limit Switches (beneath the covers, next to the drive motor on each axis) to prevent the machine from traveling beyond its limits on each axis.

The VMC-4000 Spindle Head supports a one-hp brushless DC Spindle Motor. The VMC-4500 uses a one-hp high frequency induction motor.

- ① Z Axis Cover
- ② Safety Shield
- ③ Spindle Motor
- ④ Spindle Head
- ⑤ X Axis Cover
- ⑥ Control Panel

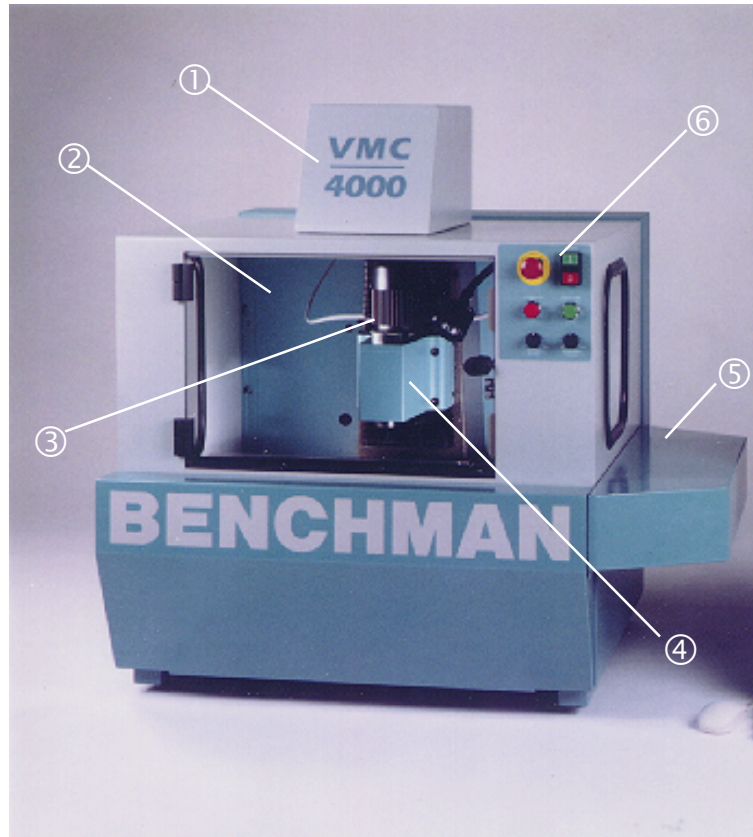

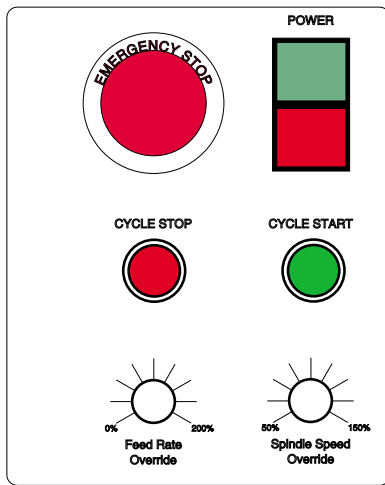

## The Front Panel Components

The Front Panel provides the operating controls shown here.

You can't miss the most important control on the machine; the **Emergency Stop** button. When pressed, this bright red palm button halts machine operation immediately. To resume operation, twist and pull the button back out. It's important that this button be pressed before performing any manual operations, like changing the stock or the tooling.

The **Power Switch** turns the machine on and off.

The **Cycle Start** and **Cycle Stop** buttons start and stop the program. Cycle Stop differs from the Emergency Stop; the program will **not** stop immediately.

The **Feed Rate Override** knob allows the operator to adjust the feed rate without entering the Control Program. The feed rate can be increased to 200% of the programmed feed rate.

The **Spindle Speed Override** knob performs the same function for the spindle speed, but only allows speeds of up to 150% of the programmed speed.

## Rear Panel Components

The key lock, power indicators, and circuit breakers for the machine are located on the rear panel of the BENCHMAN 4000.

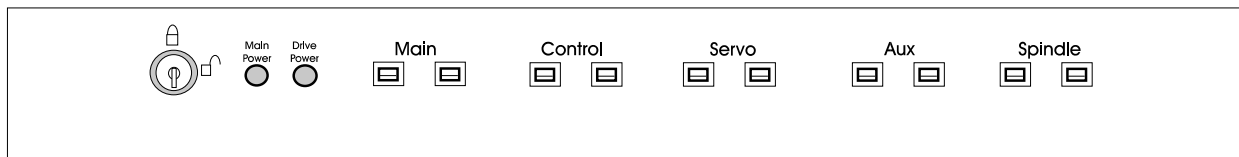

The **Key Lock Switch** keeps unauthorized persons from turning on the machine. When the Key Lock is in the unlocked position, you can turn on power to the machine using the power button on the front of the machine.

The **Main Power Light** illuminates when machine power is on. The **Drive Power Light** illuminates when the servo amplifiers are powered on.

The machine has five sets of circuit breakers for **Main Power**, the **Control**, the **Servo Motors**, **Auxiliary Outputs**, and the **Spindle**. If a circuit breaker blows, the circuit breaker switch pops out, revealing white at the top of the switch. To reset the circuit breaker, push the switch up and back into the circuit breaker until it locks in place.



---

## Intended Use of the Machining Center

The intended use of the BENCHMAN VMC-4000 Machining Center is as a conventional computer numerical controlled (CNC) vertical mill used in industrial environments.

---

## The Process

A trained operator affixes a workpiece to the machine's table and a cutting tool into the machine's spindle. The cutting tool rotates as a computer controls the machine's table and spindle movements. These motions result in the cutting tool being brought into contact with the workpiece and the cutting tool removing material from the workpiece.

The operator specifies appropriate feeds, speeds, and cutting depths for the type of tooling and workpiece material being used so as to not overload the tool or the machine.

## Cutting Tools and Fixtures

The cutting tool may be any off-the-shelf tool designed for vertical milling operations. The tool's shank is restricted to 3/4" diameter to fit a standard R8 collet. If your machine is equipped with an Automatic Tool Changer, tool shank diameter is restricted to a maximum of 1/2". The VMC-4500 uses an ER-16 collet, which restricts tool shank diameter to 3/8". Typically, the diameter of the cutter is no more than 1/2".

You can use standard off-the-shelf fixtures to mount a workpiece to the machine's table.

## Workpiece Materials

The workpiece may be ferrous or nonferrous, including, but not limited to steel, aluminum, graphite, plastic, and wax.

## Misuse of the Machine

Do NOT use the machine for tasks it was not designed to perform. Improper use or modification of the machine may damage the machine and may result in serious injury.

Misuse of the machine may result from:

- ◆ Improperly affixing a nonstandard or oversized cutting tool to the machine.
- ◆ Improperly affixing the cutting tool to the machine.
- ◆ Manually holding or feeding the workpiece into the machine.
- ◆ Improperly affixing the workpiece to the machine.
- ◆ Improperly defining feeds, speeds, and depth of cut while machining.
- ◆ Introducing hazardous materials when machining.
- ◆ Removing the safety door or making any other unauthorized modifications to the machine.
- ◆ Cutting unacceptable materials.
- ◆ Using damaged or dull tooling.

---

## Operating Conditions

You must meet all work area, power, grounding, and environmental conditions before using the machine.

---

### Work Area

You must allow at least 12.5 square feet (1.16 square meters) of work area to operate the machine.

---

### Main AC Power Supply

AC power input must satisfy the following requirements:

#### Voltage

120 VAC, 15 Amps +10% - 15% or  
230 VAC , 15 Amps +10% - 15% (International)  
1.8 KVA

#### Frequency

47-63 Hz single phase, 3 wire

---

### Grounding

A positive earth grounding system for the machine and the computer is required for proper and safe operation. The ground path must have a DC resistance of 3.5 ohms or less to a true earth ground.

Ground the machining center in compliance with all applicable electrical codes.

---

## Environmental Conditions

The machining center is designed to operate within the following environmental limits:

### Temperature

Operating: 45° to 85° F (7° to 29° C)

Storage: 0° to 130° F (0° to 54° C)

Transition: 10° c/hr

### Humidity

5% to 80% without condensation

### Altitude

Operating: 0 to 10,000 feet (3,048 meters)

Non-operating: 0 to 40,000 feet (12,192 meters)

### Shock

Non-operating: 10g in 11 milliseconds

### Vibration

Operating: 5Hz to 500Hz, 0.5G acceleration

Non-operating: 10Hz to 500Hz, 1.0G acceleration

### Noise

70 db at 8ft.

# Maintaining the Machining Center

Performing preventative maintenance on your BENCHMAN 4000 Machining Center ensures a longer, trouble-free life for the machine. We provide instructions for preventative maintenance in the following paragraphs.

Note: If you run your machine continuously (8 hours per day) at high feed rates, you should lubricate your machine every 16 hours of use.

## Ballscrews

The BENCHMAN 4000 uses pre-loaded ballscrews on all three axes. The screws are lubricated at the factory with a special long-life, waterproof ballscrew lubricant. This lubricant should last for at least 200-250 hours of machine use. After 200 hours, apply more lubricant to the screws in a thin film over the length of the screw. The ballscrew lubricant (part number 39-0000-0007) is available from Light Machines Corporation.

To gain access to the ballscrews, jog the cross slide and spindle to the extreme negative end of travel on all axes just before the limits are tripped. Remove the bellows cover by removing the two button head cap screws from the bracket holding the bellows at one end. Use a small brush to apply grease sparingly but evenly along the entire length of the ballscrew.

The VMC-4000 with the Z axis bellows cover removed to expose the Z axis linear rods and ballscrew.

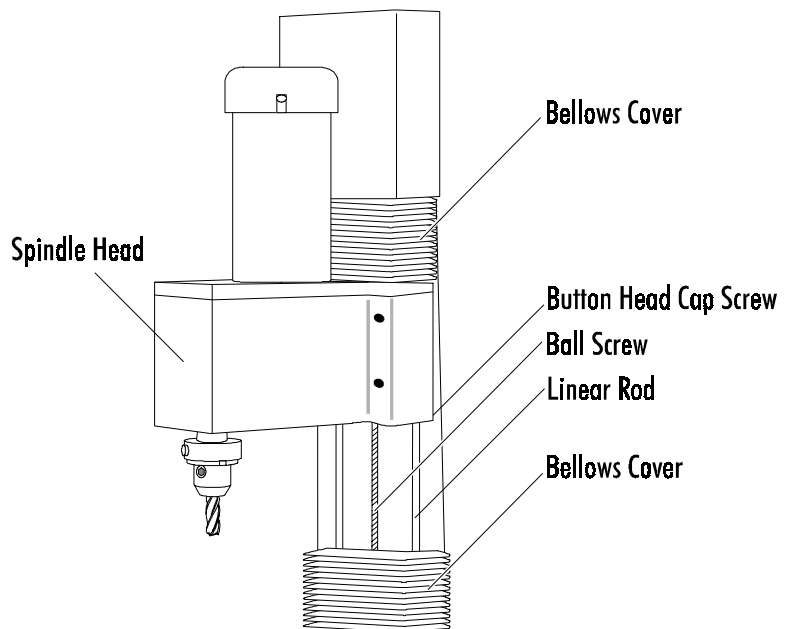

---

## Bellows Covers

It is important to clean off the Z and Y axis bellows covers. The chips can get caught in the folds of the bellows limiting travel, and also puncture and tear the material. Brush the chips off of the covers after each job to prevent this from happening.

---

## The Saddle

The saddle engages the linear rods that are attached to the base of the machining center. A ballscrew moves the saddle along the Y axis. The linear rods running through the top of the saddle engage the cross slide. A ballscrew moves the cross slide along the X axis. It is *very important* that a thin film of lubricant be maintained on the surface of the linear rods to minimize wear.

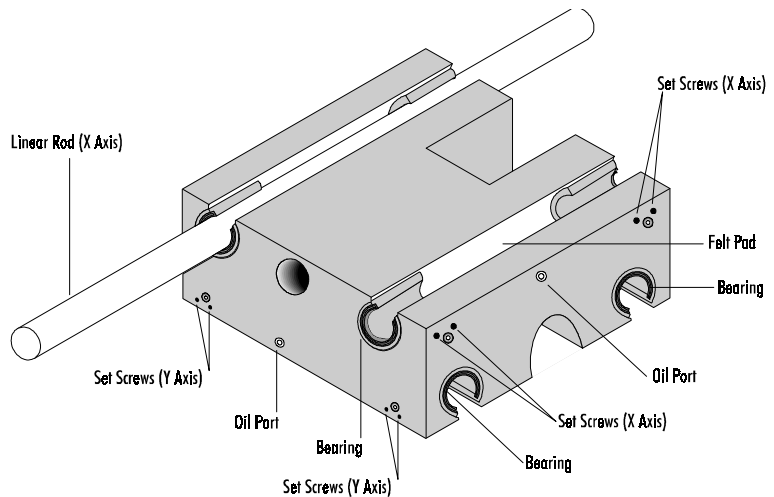

## Lubrication

There are thick oil-impregnated felt pads between the bearings in the saddle which keep a thin film of oil on the linear rods. Each rod (there are six) can be lubricated through its own oil port which is located on the saddle for the X and Y axes, and on the spindle head for the Z axis.

Lubricate the rods every 30 days or 100 hours of use, whichever comes first, using 10W engine oil. When applying oil to the oil ports, pull the trigger on the oil gun very slowly to allow the oil to be soaked up by the felt.

## Adjustment

You can adjust the linear bearings to remove any play in the saddle or spindle. The bearings are factory-adjusted and should not require adjustment for at least 250 hours of use.

Be very careful not to overtighten the bearings. Overtightening can cause overworking and overheating of the motor, excessive wear to the rods and ballscrews, backlash, and positioning errors.

### WARNING

**Always unplug the machine before making adjustments.**

The procedure is only slightly different for each axis. The end of each leadscrew is machined to fit a 7/16" wrench. You will need to jog the saddle so that you can easily access the end of the leadscrew. For the X and Y axes, jog the cross slide so that the flat is extended just beyond the saddle.

1. Jog the saddle to a position where you can access the end of the leadscrew with a 7/16" wrench. Shut off power to the system. Unplug the machine.
2. For the Y axis adjustment you will need to remove the 2 screws in the bellows cover, at the base. Fit the wrench on the leadscrew, turning it back and forth to check the amount of play in the bearing. If you need to use excessive force to turn the leadscrew, the bearing is adjusted too tightly.
3. Loosen all eight recessed allen setscrews on the axis you are adjusting. They are located on the four sides of the saddle for the X and Y axes, and on the sides of the spindle for the Z axis.

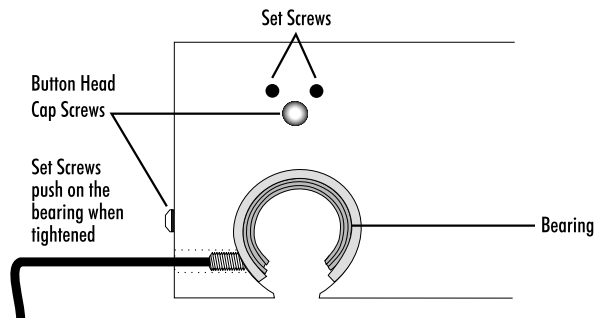

4. Tighten the two setscrews for each bearing while checking the force it takes to turn the ball screw. Tighten the setscrews (applying approximately 4-8 in/lb of torque) until the force it takes to turn the leadscrew increases when turning it by hand. Then back the setscrews off by 1/8-turn. Repeat this procedure for all four bushings on each axis.
5. Remove the tools from the work area, and return power to the machine.

# Spindle

## Spindle Head

Light Machines ships the BENCHMAN 4000 with a factory-aligned two-piece Spindle Head. You should not attempt to align the Spindle Head without first contacting your local dealer, or Light Machines.

## Spindle Motor

The spindle motor on the BENCHMAN 4000 Machining Center is a 1hp brushless DC motor. The only wearing parts on the motor are the ball bearings on the motor shaft. The ball bearings are sealed, lifetime-lubricated bearings and do not require special maintenance.

The VMC-4500 uses a direct drive, 1 hp high frequency induction spindle motor. The spindle head is a sealed unit, and utilizes a pressurized air curtain to ensure that no dirt or moisture contaminates the motor shaft or bearings. You should not attempt to lubricate these bearings at any time.

## Checking for Spindle Shaft Play

The spindle shaft is preloaded against sealed ball bearings that do not require lubrication or user maintenance. You should, however, check the spindle shaft for both radial play (side to side) and axial play (up and down). If the spindle shaft starts to develop play (or begins to make unusual noises while in operation), contact your local dealer, or Light Machines (800-221-2763).

To check for play, grip the spindle shaft and push and pull it in each direction along both axes. The spindle shaft should be firm against your pressure.

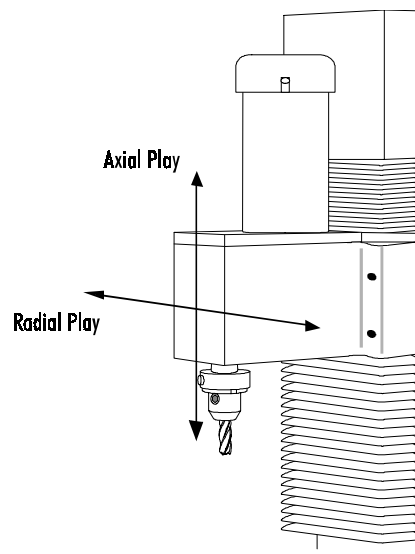



---

**CAUTION**

---

Do not overtighten the drive belt.  
Excessive tension will damage  
the motor shaft.

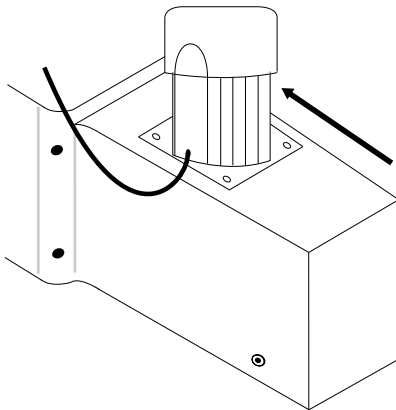

## Belts

### Spindle Belt

The spindle motor drives the spindle shaft with a serpentine belt. If the belt becomes loose, it will wear out quickly. The belt squealing at slow speeds is an indication of a loose or worn belt. Also, if the belt is loose, you can feel backlash between the spindle motor shaft and the spindle shaft. To check for backlash, rotate the spindle shaft back and forth slightly and observe the fan inside the motor. Make sure the fan rotates as soon as you reverse the direction of the spindle shaft. If there is backlash, follow the directions below.

**WARNING**

**Always unplug the machine before making adjustments.**

To adjust the spindle belt:

1. Make sure all power to the system is shut off. Unplug the machine.
2. Loosen the four socket head cap screws on the spindle motor a few turns.
3. If you are only adjusting the belt, simply push the motor toward the back of the machine and tighten the screws.
4. Turn the spindle shaft to make sure the spindle runs freely by hand and the spindle motor turns. If everything appears all right, try turning on the spindle motor and slowly turning up the spindle speed. Check for excessive vibration.

### Axis Drive Belts

The axis drive belts are located between the motors and ballscrews on each axis. Normally, they should not need adjustment. If you suspect that there may be a problem with the axis drive belts, please contact your local dealer or Light Machines Technical Support.

---

## Maintaining the PC in a Shop Environment

There are a few general guidelines for maintaining your personal computer and software in a shop environment. See your owner's manual for maintenance procedures that are specific to your computer.

---

### Caring for the Computer

Follow these general rules for computer care.

- ◆ Keep the computer and peripherals (mouse, keyboard, external drive, printer) out of direct sunlight and away from sources of heat and in a relatively clean environment (i.e., not right next to the foundry room).
- ◆ Cover the computer and keyboard with a dust cover when not in use.
- ◆ Keep liquids (soda, coffee, cutting fluid, grease) away from the computer and peripherals.
- ◆ Keep oil, grease, metal chips and excess dust away from the computer, keyboard and floppy disks.
- ◆ Use grounded, three-prong outlets for the computer and peripherals. Take precautions against current overload. A line-surge suppression unit can be purchased at your local computer store to help alleviate this problem.
- ◆ Don't block the vent holes in the computer or drives; they are required for air circulation.

---

## Caring for Floppy Disks

Floppy disks are simple to use but require a few precautions to maintain their integrity.

- ◆ Don't touch the magnetic disk part of the disk (the shiny, record-like part inside the disk jacket). Dust or grease from your hand can ruin any part of the disk that you touch and can possibly destroy the entire disk.
- ◆ Keep disks in a disk box or special disk container instead of spreading them out on your work space.
- ◆ Handle disks gently, don't bend or crease them.
- ◆ Don't write on disk labels with a ball point pen. If you must write on the label, always write very lightly with a felt tip pen.
- ◆ Keep disks in a clean, cool environment away from excess amounts of dust, heat, or sun.
- ◆ Beware of getting machining fluids on the disks. If you spill a liquid or cutting fluid on a disk, it is 99 percent certain that the disk and all the data on it can never be used again.
- ◆ Keep disks away from all magnetic sources including telephones, high-voltage power sources and mill motors.
- ◆ Make back-up copies of all NC program disks each time you update them.
- ◆ Print copies of all NC programs in case of disk failure or lost disks.

No matter how cautious you are, disks will go bad; they develop bad blocks (unreadable surfaces). If this happens while you are editing a program, the program will be lost. The solution to this disaster is simple—make back-up copies.

---

## Factory Installed Options

BENCHMAN is available with a number of factory installed options. This section includes information about each one.

---

### 10,000 RPM Spindle

The 10,000 RPM Spindle (ACC-5105) allows you to machine materials at speeds up to 10,000 RPM.

---

### Digitizing Package

The ACC-5261 Digitizing Package includes a digitizing probe and software that lets you digitize existing parts and models to capture 3-D surface data. The easy-to-use PC-driven package provides reverse engineering capabilities with BENCHMAN. It can generate files in three different formats; an NC part program, an ASCII text file with XYZ data points, and a DXF 3-D mesh file.

The Digitizing Package includes a touch signal probe, a probe interface cable, a 20mm long stylus with 3mm diameter head, a 20mm stylus extension, the Digitizing Package User's Guide, the Digitizing Package software on 3.5" diskettes, and an 8 mm Collet.

---

### Air Vise

The Air Vise (PNU-4117) has jaws that open to a maximum of 3.0 inches. The vise comes with a solenoid valve and all the tubing required to interface with the Pneumatic Control option (PNU-4110) if so equipped.

---

## Automatic Tool Changer

A four-station Automatic Tool Changer (ATC) is available for the BENCHMAN 4000. The ATC (ACC-4105/4107) makes multiple tool programming an easy operation. Tool changes are written into the NC program and executed automatically during machining.

---

## Graphite Dust Collection System

The Graphite Dust Collection System (PNU-4130) uses a high volume vacuum system to remove fine graphite dust from the enclosure during machining. A filter is fitted to one of the enclosure windows, while a duct is fitted to the other. The duct runs into a separate vacuum module, which houses the vacuum motor and dust collector. Refer to the documentation provided with the system for more information.

---

## 4th Axis Control

This option allows for machining on the X, Y, Z, and A axes. The 4th Axis Control (ACC-5406) provides the software to program machining on all four axes. The 5C Rotary Positioner (ACC-5224) is available as a separate option.

---

## Pneumatic Control

The Pneumatic Control option (PNU-4110) allows programmed control of Light Machines-installed pneumatic options, such as the Air Vise and Pneumatic Door Opener. It can also provide control for up to two (2) user installed pneumatic devices operating at a minimum pressure of 75psi.

## Flood Coolant

The BENCHMAN 4000 is available with Flood Coolant (ACC-5205). A pump provides coolant to the workpiece resulting in reduced tool wear, and evacuation of chips. The coolant pump and plumbing are installed at the factory; the operator is required to fill the coolant sump.

Flood Coolant is not available on the VMC-4500.

---

### CAUTION

---

Use only the recommended type of coolant for the VMC-4000. Use of any other type of coolant may cause corrosion to exposed areas of the machine, or damage the machine.

## Filling the Sump

Benchman requires a minimum of seven (7) gallons of coolant, and holds a maximum of nine (9) gallons. Light Machines recommends the use of Valcool Coolant. Using any other brand of coolant may cause corrosion of any parts that come in contact with the coolant. The coolant sump is shipped dry, and must be filled before using the flood coolant system.

To fill the sump:

1. Make sure the coolant is **thoroughly** mixed before filling the sump. The coolant concentrate should be diluted with water according to the following formula: 1:17 (6%) to 1:25 (4%).
2. Press the Emergency Stop button on the front panel.
3. Open the safety shield of the machining center.
4. Carefully add at least seven (7), and not more than nine (9) gallons of the coolant mixture to the sump.
5. Close the safety shield, and return power to the machine.

Because of evaporation of water in the coolant and other minor losses, coolant levels should be checked weekly, along with other maintenance. The coolant also becomes dirty, and should be replaced periodically.

## Flood Cooling Setup and Operation

Flood Coolant is a factory installed option. The BENCHMAN 4000 comes flood coolant ready.

### Coolant Flow

The pump draws coolant from the sump in the bottom of the enclosure, and cycles it through the adjustable nozzle directly onto the workpiece. The coolant pump is located beneath a cover in the right rear corner of the enclosure. It can be turned on and off either through the user interface, or by M codes in the NC program (M08/on, M09/off). The nozzle tube is adjustable, and has a petcock built into it to control the flow of coolant.

The coolant runs off the workpiece, taking the chips with it, and back into the sump area. There are screens over the sump to separate the chips from the coolant. These screens should be cleaned periodically. If the chips are not removed from the screens, they will block the flow of coolant back into the sump.

**Important!** Do not drill or make holes of any sort in the enclosure, especially on the back panel. If holes are drilled to mount an aftermarket accessory or other device, coolant is likely to leak out and could be hazardous to other components of the machine.

---

## CAUTION

---

When coming in contact with coolant, always adhere to the manufacturers handling instructions.

## Maintenance

Flood coolant machines require only a little more maintenance than non coolant machines. It is important to perform the following maintenance.

- ◆ Keep sump screens clean to maintain the flow of coolant through the system.
- ◆ Check and refill coolant levels as necessary.
  1. Open operator door.
  2. Remove one of the sump screens.
  3. Make sure the coolant is within an inch of the screen.
  4. Refill if necessary.
- ◆ Coolant should be replaced once a month, depending on machine usage.
  1. Press the Emergency Stop Button on the controller and remove power from the machining center.
  2. Place an approved ten (10) gallon container below the drain plug at the rear of the machining center.
  3. Remove the drain plug.
  4. When the coolant has drained into the container, replace the plug and properly dispose of the used coolant.
  5. Open the safety shield and refill the sump with fresh coolant. Be sure the coolant is mixed thoroughly before filling the sump. **Do not** try to mix coolant in the sump.





# Getting to know the Control Program

Starting the Control Program

If You Need Help...

Exploring the Control Program Screen

## Starting the Control Program

To start the Control Program:

From **Windows 95** or **Windows NT 4.0** select the Start menu, and then Programs> Benchman> BENCHMAN. You can also create a shortcut by opening the Benchman directory and dragging BENCHMAN.EXE onto your desktop.

From **Windows NT** double-click the BENCHMAN 4000 icon in the BENCHMAN 4000 group.

## Starting the Control Program in Simulate Mode

If this dialog box appears when you start the Control Program, the Motion Control Card that came with your machining center has not been properly installed (see Section A).



If you do not have the Motion Control Card installed you can still edit and verify NC part programs without the machining center by running the Control Program in Simulate Mode.

To start the Control Program in Simulate Mode, select Cancel. When the next dialog box appears, select Simulate.

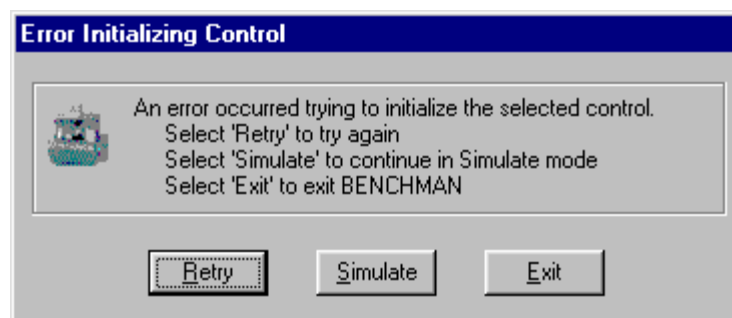

---

## If You Need Help...

You can access on-line help by using the commands under the Help Menu, or by pressing F1.

For information on the functions and screens in the Control Program software, refer to Section E, Control Program Reference.

# Exploring the Control Program Screen

You should become familiar with the main parts of the Control Program screen before you begin using the Control Program to run NC part programs. The following are the default components that make up the screen.

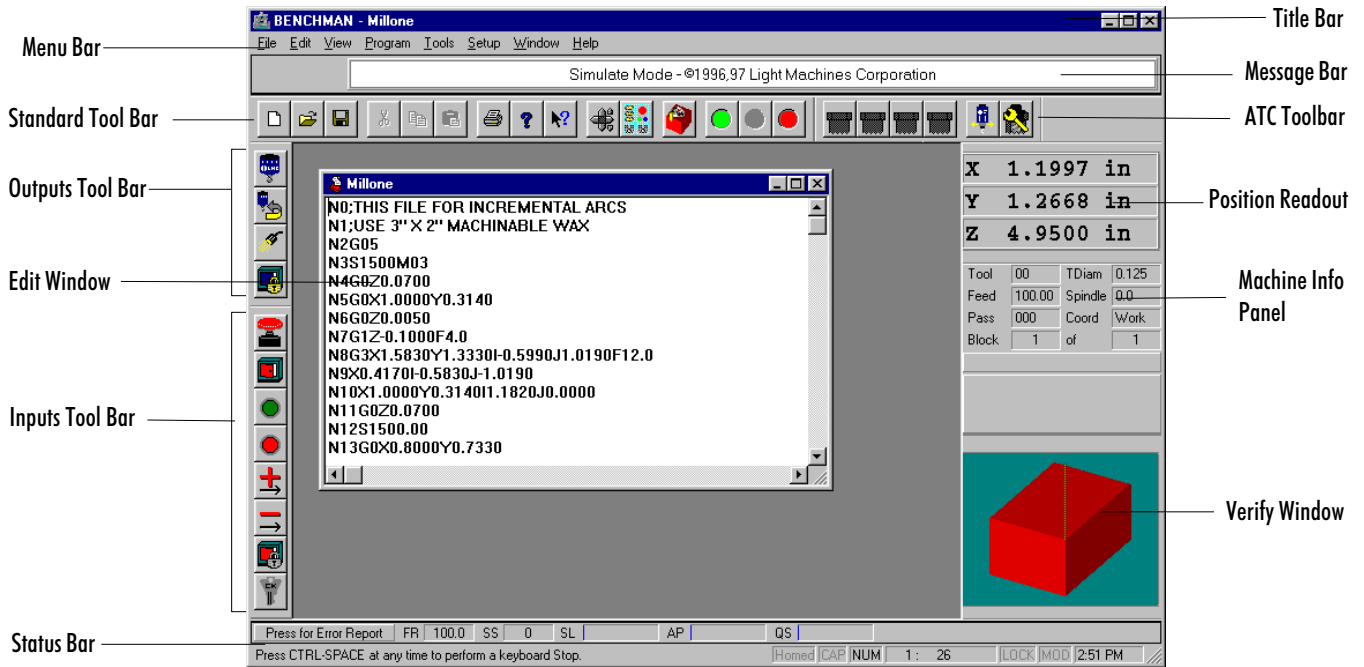















## Menu Bar

The Menu Bar carries all of the menu commands for the Control Program. For a full explanation of each menu and its relative commands, see Section E, Control Program Reference.







## Standard Tool Bar

The Standard Tool Bar provides easy access to the most often used Control Program commands.

<b>Tool</b>	<b>Function</b>
 New File	Begin a new NC part program file.
 Open File	Open an existing NC part program file.
 Save File	Save current NC part program file to disk or drive.
 Cut NC Code	Cut selected code from program and place on clipboard.
 Copy NC Code	Copy selected code to clipboard.
 Paste NC Code	Paste code from clipboard to cursor position in program.
 Print File	Send program to printer.
 Help	Access Help program.
 Context Help	Obtain help on selected object.
 Jog Control	Access Jog Control Panel.
 Operator Panel	Access Operator Control Panel.
 3-D Verification	Access 3-D tool path verification.
 Run (green)	Run the current NC part program.
 Pause (yellow)	Pause the currently running NC part program.
 E-Stop (red)	Halt the currently running NC part program.

## ATC Tool Bar

The ATC Tool Bar provides easy access to the functions of the Automatic Tool Changer. It allows the user to insert tools from each of the tool stations into the spindle, clamp and unclamp the draw bar, and configure the ATC.

Tool	Function
	Tool Station 1      Inserts the tool in Station 1 into the spindle.
	Tool Station 2      Inserts the tool in Station 2 into the spindle.
	Tool Station 3      Inserts the tool in Station 3 into the spindle.
	Tool Station 4      Inserts the tool in Station 4 into the spindle.
	Draw Bar      Clamps and unclamps ATC Draw Bar.
	Configure ATC      Opens Configure ATC dialog box.

Note: The ATC is not available on the VMC-4500.

## Outputs Tool Bar

The Outputs Tool Bar is an active tool bar. It provides switches activate or deactivate the named output. The feature is on when the buttons are depressed. If you hold the mouse over the button, a message will be displayed on the Status bar stating whether the output is on or off.

Tool	Function
 Spindle	Turns the Spindle on and off.
 Spindle Direction	Reverses spindle direction.
 Coolant	Turns coolant flow on and off. (Optional)
 Light	Turns the light on and off.
 Door Lock	Locks and unlocks the Door.
 Air Vise	Clamps and Unclamps the air vise (optional).
 Door Opener	Opens and closes the pneumatic door opener (optional).
 Pneumatic Device	Output control for a general pneumatic device (optional).

## Inputs Tool Bar

The Inputs Tool Bar is an informational tool bar. It provides information on the **state** of the input. An input is active (on) when the button is depressed.

Tool	Function
	E-Stop Indicates when the Emergency Stop is on.
	Safety Shield Indicates whether the Safety Shield Interlock is open.
	Cycle Start Indicates the state of the Cycle Start input.
	Cycle Stop Indicates the state of the Cycle Stop input.
	Positive Limit Indicates when the Positive Limit switch is on.
	Negative Limit Indicates when the Negative Limit switch is on.
	Door Lock Indicates the state of the door lock.
	Machine Keylock Indicates the state of the Machine Key Lock.



---

## IMPORTANT!

---

Always verify NC programs after editing to ensure that your changes will not cause a tool crash!

Here is an example of the Edit Window for the NC part program MILLONE.NC.

## Edit Window

Whenever you open an NC part program file, it appears in its own edit window. These windows have the same characteristics as other Windows 95 windows (scroll bars, minimize/maximize buttons, etc.). You can have multiple edit windows open at a time, the number of which depends on available memory.

By default, each new window is locked; you can not edit a locked window. To unlock the window, use the Lock command under the Edit Menu.

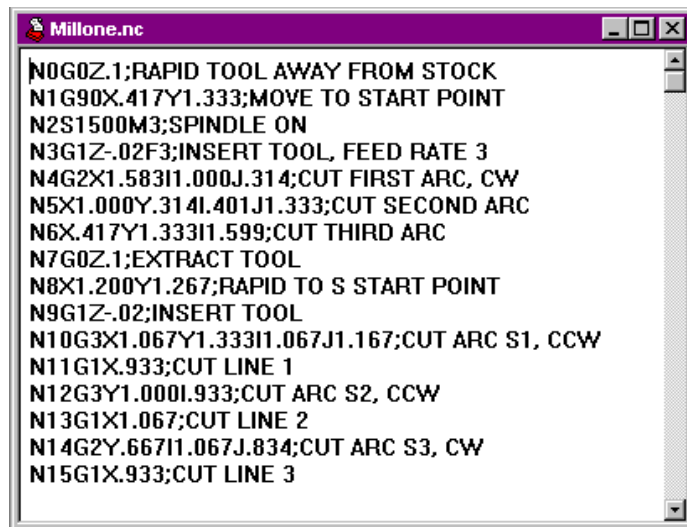

```
Millone.nc
N0G0Z.1;RAPID TOOL AWAY FROM STOCK
N1G90X.417Y1.333;MOVE TO START POINT
N2S1500M3;SPINDLE ON
N3G1Z-.02F3;INSERT TOOL, FEED RATE 3
N4G2X1.583I1.000J.314;CUT FIRST ARC, CW
N5X1.000Y.314I.401J1.333;CUT SECOND ARC
N6X.417Y1.333I1.599;CUT THIRD ARC
N7G0Z.1;EXTRACT TOOL
N8X1.200Y1.267;RAPID TO S START POINT
N9G1Z-.02;INSERT TOOL
N10G3X1.067Y1.333I1.067J1.167;CUT ARC S1, CCW
N11G1X.933;CUT LINE 1
N12G3Y1.000I.933;CUT ARC S2, CCW
N13G1X1.067;CUT LINE 2
N14G2Y.667I1.067J.834;CUT ARC S3, CW
N15G1X.933;CUT LINE 3
```

## Status Bar

The Status Bars display information about the Machining Center and the computer. The top of the bar shows information about the machine itself, while the bottom displays NC program information, and the time. The top left side of the Status bar displays any current machine error conditions. The bottom left side of the Status Bar is reserved for operator messages such as the one displayed here. If any of the areas are grayed-out, the feature is considered off. See page E-11 for more information about the Status Bar.

- ◆ Machine Error Conditions: Displays current machine errors, if any.
- ◆ FR: Current machine Feed Rate.
- ◆ SS: Current Spindle Speed.
- ◆ SL: Spindle Load; current load on the spindle.
- ◆ AP: Relative ATC air pressure
- ◆ QS: Queue Status, or percentage of queue currently in use.
- ◆ The Machine Homed state: Black if the machine is currently homed.
- ◆ The Caps Lock key state: Black if the Caps Lock feature is on. Some NC programmers prefer to type their programs in capital letters. When the Caps Lock feature is on anything you type will be displayed in capital letters. Press the Shift key to type lower case letters.
- ◆ The Num Lock key state: Black if the Num Lock feature is on. Some NC programmers prefer to use the numeric keypad on the keyboard to enter figures. The Num Lock feature must be on to do this.
- ◆ Current Line : Total Lines: Displays the line the cursor is currently on, and the total number of lines in the NC program.
- ◆ The file locking state: Black if the NC program file is locked.
- ◆ The file modified state: Black if the NC program has been modified since being opened.
- ◆ The current time (according to your computer).

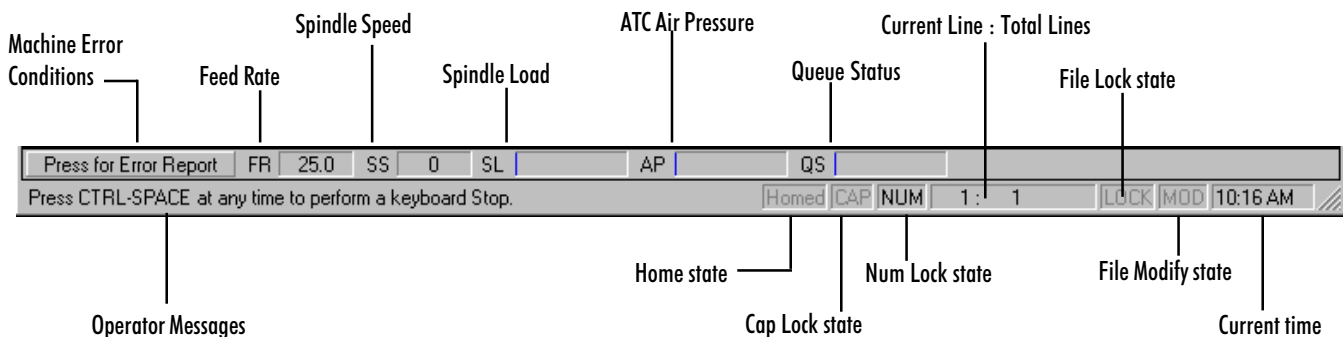

## Position Readout

The Position Readout provides information on the current X, Y and Z coordinates of the tool position. The units of measure in the Position Readout are determined by the Units command under the Setup Menu.

<b>X</b>	<b>0.0000 in</b>
<b>Y</b>	<b>0.0000 in</b>
<b>Z</b>	<b>0.1000 in</b>

### Tips:

- ◆ If you wish, you can move the Position Readout Window, and the Machine Info Window to another part of the screen. Hold the Ctrl key down, then click and drag the window. Holding the key down allows you to place it anywhere on the screen. To keep the window as a floating window, right-click on the window and uncheck the "dockable" command.
- ◆ When the window is floating (not docked) you can resize it just like any other window.
- ◆ You can double click on the Position Readout to bring up the Go To Position dialog box.
- ◆ For more information on moving and resizing windows, see the Control Program Reference section in Section E of this manual.

## Machine Info Panel

The Machine Info Panel provides information on the current tool, tool diameter, feed rate, spindle speed, number of passes made, coordinate system in use, as well as the current block and total number of blocks in the program.

Tool	10	TDiam	1.5
Feed	1.00	Spindle	1500.0
Pass	000	Coord	WWork
Block	1	of	1

When a part program is running, the Info Panel also provides dynamic display of the elapsed machining time and highlights the block of code that is currently being executed.

Tool	10	TDiam	1.5
Feed	1.00	Spindle	1500.0
Pass	000	Coord	WWork
Block	1	of	1
Part Time 03:10			
4 N3G1Z-.02F3;INSERT TOOL, FEED RA			
5 N4G2X1.58311.000J.314;CUT FIRST A			
6 N5X1.000Y.314I.401J1.333;CUT SEC			

Elapsed time indicator

Current, previous and next block

Tips:

- ◆ If you wish, you can move the Verify Window to another part of the screen. Hold the Ctrl key down, then click and drag the Verify Window. Holding the key down allows you to place the windows anywhere on the screen. To keep the Verify window as a floating window, right-click on the window and uncheck the "dockable" command.
- ◆ Pressing the right mouse key while in the Verify window displays a pop-up menu with Verify-related commands.
- ◆ When the Verify Window is floating (not docked) you can resize it just like any other window.
- ◆ You can double-click on the Verify Window to bring up the Verify Setup dialog box.

## Verify Window

The Verify Window displays a simulation of your part program when you select the Verify command from the Program Menu, or when you click the Verify Program button on the Standard Tool Bar.

Tool path verification can be performed in centerline view or solid view. Centerline view is based on the centerline of the tool. Solid view is a solid representation of the tool and workpiece.

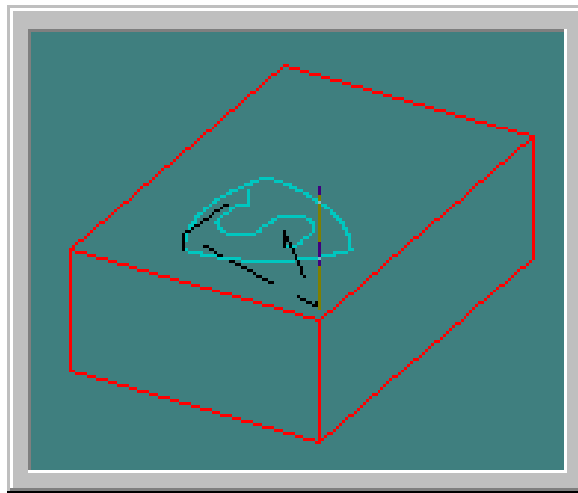

Centerline View

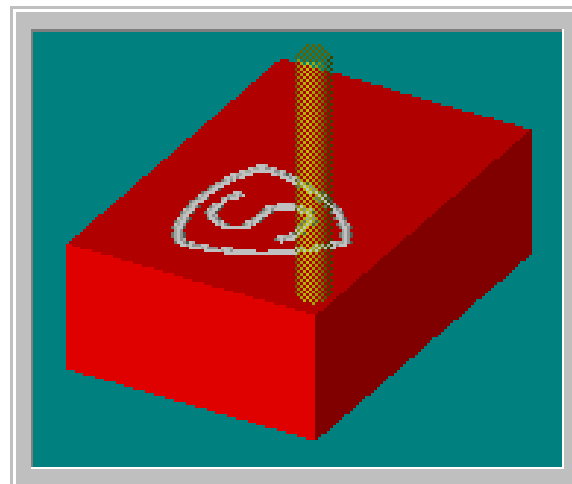

Solid View

# Tutorial: Machining a Sample Part

Safely Running the Machining Center

Running a Sample NC Program

---

## Safely Running the Machining Center

Like any other power tool, the BENCHMAN 4000 is a potentially dangerous machine if operated in a careless manner. The importance of safely operating the BENCHMAN 4000, including the need for protection against personal injury and the prevention of damage to the equipment, can not be stressed enough. You will find more information on safe machining in the Reference Guide: Section J.

---

### Safety Rules

The following safety rules should be practiced by all operators of the BENCHMAN 4000 Machining Center.

#### Remove Adjusting Keys and Wrenches

Make a habit of checking that keys and adjusting wrenches are removed from the machining center before operating the machine.

#### Do Not Force a Tool

Select the feed rate and depth of cut best suited to the design, construction and purpose of the cutting tool. It is always better to take too light a cut than too heavy a cut.

#### Use the Right Tool

Select the type of cutting tool best suited to the milling operation. Don't force a tool or attachment to do a job it wasn't designed to do.

#### Secure the Workpiece

Be certain that you have firmly secured the workpiece on the cross slide and the cutting tool in the spindle before turning on the spindle motor.

#### Turn the Spindle By Hand Before Starting

Manually turning the spindle allows you to safely determine that the tool will not hit the machining center bed, cross slide, or stock on start up.

#### Tighten All Holding, Locking and Driving Devices

Tighten the work holders and tool holders. Do not over-tighten these devices. Over-tightening may damage threads or warp parts, thereby reducing accuracy and effectiveness.

---

## IMPORTANT!

---

Always use the Emergency Stop Button in an emergency situation. It is the best way to stop the machine.

**Note:** You should use the Emergency Stop button to disconnect power to the machining center when changing tools, or when mounting or removing a workpiece.

Place a Pause command in your part program. Once the pause is executed, push in the Emergency Stop button and open the safety shield.

When you are finished with the changes, close the shield. Pull out the Emergency Stop button, then press Enter on the computer keyboard to resume running the program.

## Making Emergency Stops

Before you run the BENCHMAN 4000 for the first time, you should know how to stop the machine should an emergency situation arise. There are a number of ways an emergency stop can be initiated on the Machining Center: by pressing the Emergency Stop button, by simultaneously pressing the Control and Space Bar keys on the computer keyboard, by activating one of the limit switches, or by activating the safety door interlock switch.

### Stopping with the Emergency Stop Button

There is an Emergency Stop button located on the front panel of the machining center; it has an oversized red cap. Before power can be applied to the machining center, the Emergency Stop button must be pulled fully out from the front panel. Rotate the cap clockwise to release it. The Emergency Stop button works on the spindle even if the computer is turned off.

In the event of some machine or operator emergency, you can immediately kill power to the machining center by pushing in the Emergency Stop button. Pushing in the Emergency Stop button terminates the part program. Wait until the machining center has completely stopped moving before opening the safety shield.

When the error has been corrected, and the Emergency Stop button is reset (rotated and released), press Enter on the keyboard to close the error dialog box that appeared when the Emergency Stop button was pressed. Take the necessary steps to ensure that the problem is fixed, (i.e., edit the part program to remove the tool crash, check the position of the workpiece, etc.) before running the program again. You may need to reinitialize (reset the point of origin for all axes) the machining center using the Set Position command from the Setup Menu, and you may need to home the machine again.

The Emergency Stop button should be your first target when a critical error occurs. You do not need to use it in situations where safety or reaction time is not an issue. For example, if you start to run a program but notice that the tool is moving towards the wrong corner of the workpiece, use a software stop to halt the program and reset the origin of the workpiece.

### Stopping with the Computer Keyboard

The execution of the part program can be interrupted by pressing keys on the computer keyboard. To stop the part program with the keyboard, press the Control key and Space Bar simultaneously. The cutting stops immediately and the cutting tool remains in position.

The reason for stopping the program will determine the method used to re-start the program. If the problem was not a critical error, and you want to continue from the same position, select the Run/Continue command from the Program Menu. In the Start At Line box, enter the number of the last line executed, then click on the Run Program button. (The last line executed is displayed on the Machine Info Panel.)

## Stopping with a Limit Switch

The BENCHMAN 4000 is equipped with limit switches to sense the end of travel on each axis. If the table travel exceeds the end of travel on any axis, a limit switch is activated and shuts down machine operation.

Once a limit switch is activated, the tool must be jogged away from it using the Jog Control keypad (selected from the View Menu).

To move the cross slide away from the limit switch, you must jog it in the opposite direction. Each axis has a positive and a negative limit. If a *positive* limit is hit, you must jog away from it in a *negative* direction. If a *negative* limit is hit, you must jog away from it in a *positive* direction. If both a positive and a negative limit are hit, you must jog off the negative limits first.

If the cross slide comes close enough to the end of travel on any axis to activate a limit switch, the following procedure must be followed to restore normal operation.

1. Select Jog Control from the View Menu or the Standard Tool Bar.
2. Press the appropriate jog key on the jog keypad to move the cross slide away from the triggered limit switch.
3. Check your initial machine set up to make sure it was performed correctly.



## Running a Sample NC Program

When you installed the Control Program, an NC part program file named MILLONE.NC was copied into the BENCHMAN 4000 directory along with the other files. This program is meant to machine a 3" x 2" x 1.5" piece of machinable wax. You will be using this file to create your first workpiece on the machining center.



### WARNING

Do not attempt to operate the BENCHMAN 4000 without reviewing all of the safety precautions set forth in the Reference Guide: Section J.

## Open MILLONE.NC



1. Select the Open command from the File Menu, or click on the Open button on the Standard Tool Bar. The Open dialog box appears.
2. Double-click on MILLONE.NC, or click on the filename and then click on the Open button. The edit window for MILLONE.NC appears.

```
Millone.nc
N0G0Z.1;RAPID TOOL AWAY FROM STOCK
N1G90X.417Y1.333;MOVE TO START POINT
N2S1500M3;SPINDLE ON
N3G1Z-.02F3;INSERT TOOL, FEED RATE 3
N4G2X1.583I1.000J.314;CUT FIRST ARC, CW
N5X1.000Y.314I.401J1.333;CUT SECOND ARC
N6X.417Y1.333I1.599;CUT THIRD ARC
N7G0Z.1;EXTRACT TOOL
N8X1.200Y1.267;RAPID TO S START POINT
N9G1Z-.02;INSERT TOOL
N10G3X1.067Y1.333I1.067J1.167;CUT ARC S1, CCW
N11G1X.933;CUT LINE 1
N12G3Y1.000I.933;CUT ARC S2, CCW
N13G1X1.067;CUT LINE 2
N14G2Y.667I1.067J.834;CUT ARC S3, CW
N15G1X.933;CUT LINE 3
```

## Adjust the Verify Settings

After loading the NC program, you need to adjust the Verify Settings specifically for the part you are about to machine. To view the Verify Setup dialog box, double click on the Verify window. You may also select Verify from the Program Menu, or select Verify from the Standard Toolbar then click on the Verify Settings button.

The Verify Setup dialog box appears.

The Verify Setup dialog box allows you to alter the viewpoint of the tool and workpiece in the Verify Window.

The View panel allows you to:

- ◆ Alter the Style (Solid or Centerline)
- ◆ Zoom in, zoom out or fill the window by selecting All
- ◆ Look at the workpiece in two or three dimensions

You can also alter the view of the part by adjusting the sliders on the Preview box.

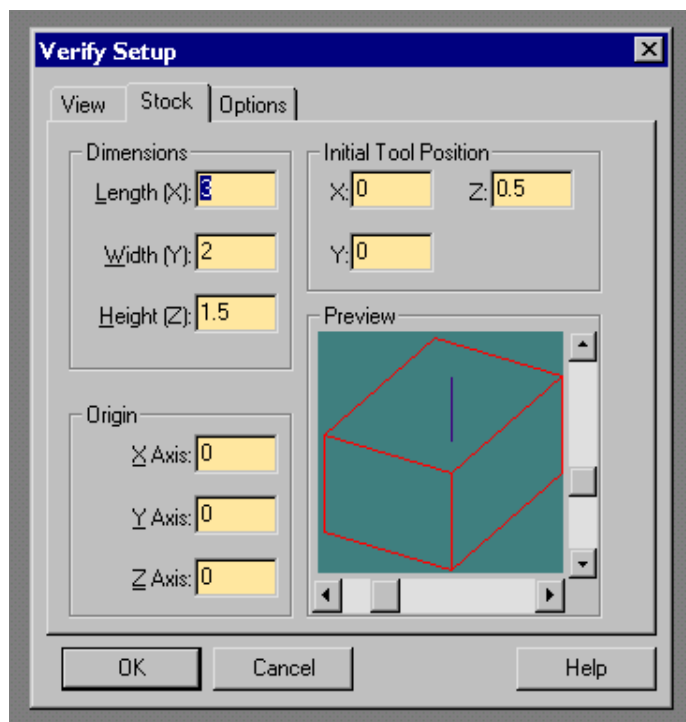

### Adjust the View

1. Select the View tab.
2. Select either Solid (for a solid representation), or Centerline (for a centerline representation of the tool and workpiece) from the Style area.
3. Select Isometric from the Preset View area for a three dimensional view of the part.

## Adjust the Stock

1. Select the Stock tab.
2. Enter the stock Dimensions for the MILLONE.NC program. The stock dimensions are X=3", Y=2" and Z=1.5".
3. Set the Initial Tool Position to X=0, Y=0 and Z=0.5.
4. Set the point of Origin to zero on all three axes.
5. Select OK. The dialog box closes, and the shape of the workpiece in the Verify Window changes.

The Stock panel allows you to:

- ◆ Enter the dimensions of the workpiece
- ◆ Set the initial position of the tool
- ◆ Set the point of origin for the workpiece

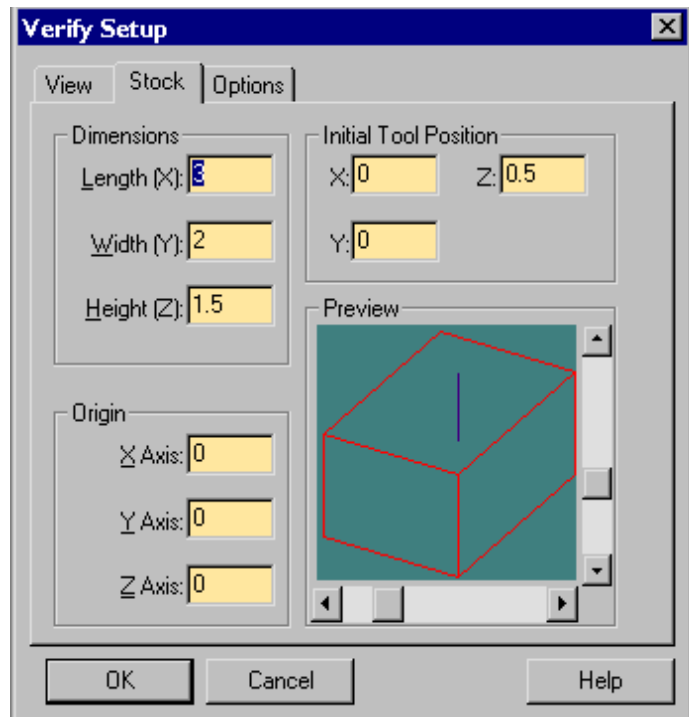

## Define the Tool

To machine this part, you will use an 1/8" HSS end mill. You will use the parameters for this particular end mill for the tool path verification as well. To define the tool parameters, first add the tool to the tool library, then select the tool for verification.

### Add the Tool to the Library

1. Select Setup Library from the Tools Menu. The Setup Tools dialog box appears. There is a 1/8" end mill already defined. However, our purpose is to learn to use the system, so we will create another 1/8" end mill.

To define a new tool, select an undefined tool, as we have here, then select a Tool Type.

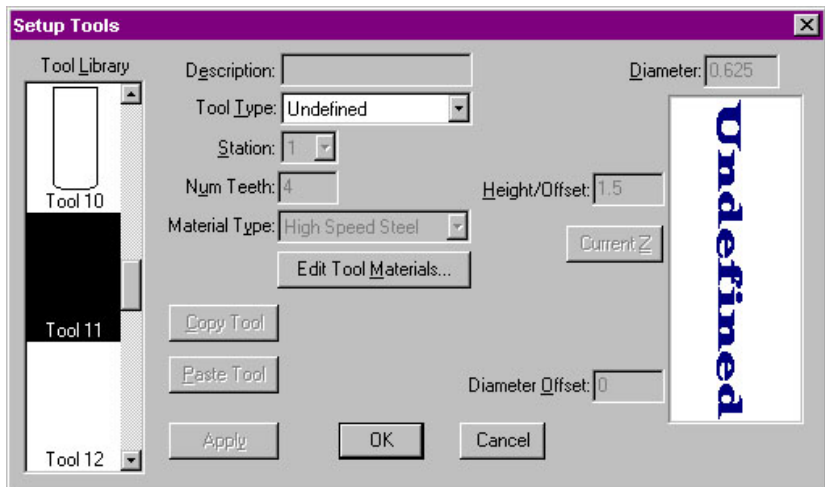

2. In the Tool Library scroll box, scroll down to tool 11, which is undefined at this point. Highlight Tool 11 by clicking on it with your mouse.
3. In the Tool Type pull-down list, select End Mill.
4. Enter "End Mill" in the Description box.
5. Enter 0.125 in the Diameter box.

- Click on the Apply button. You have just defined a new tool in the library. From now on, whenever you need an 1/8" HSS end mill it will be there.
- Click on OK to exit the Tool Library.

Here is the newly defined tool, an 1/8" HSS end mill that has four teeth and a height offset of 1.5 inches.

These are the same tool parameters you will use when actually machining the MILLONE.NC part.

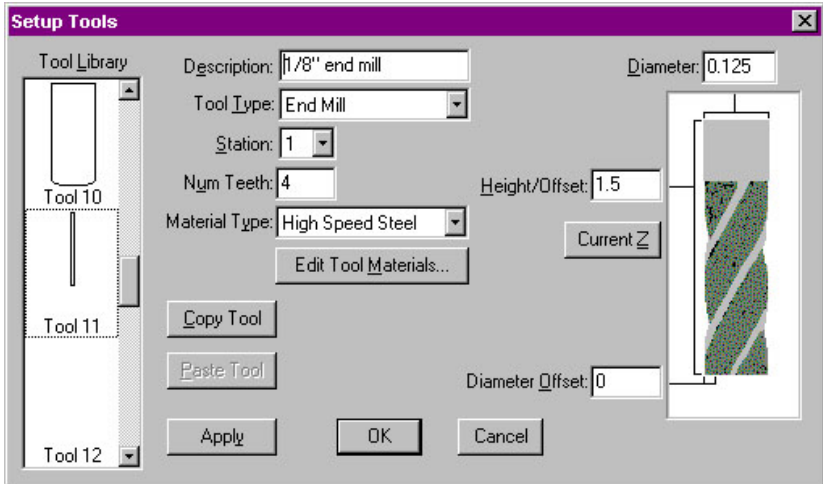

### Select the Tool for Verification

- Select Tool from the Tools Menu. The Select Tool for Use dialog box appears.
- Select Tool 11 from the pull-down list.
- Click on the Select Tool button.

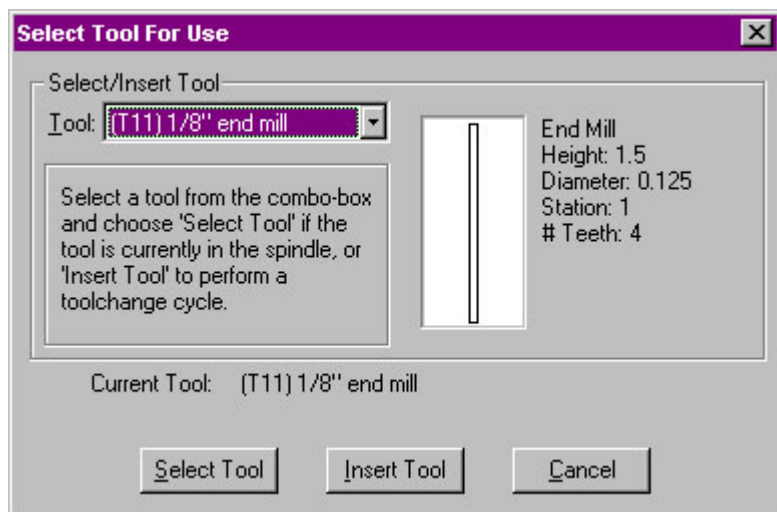

## Verify MILLONE.NC

Tool path verification allows you to check for programming errors before actually running the part program on the Machining Center.

1. Select Verify from the Program Menu. The Verify Program dialog box appears. The default starting line for the program is Line 1. When verifying a program for the first time, you should begin at the first block.

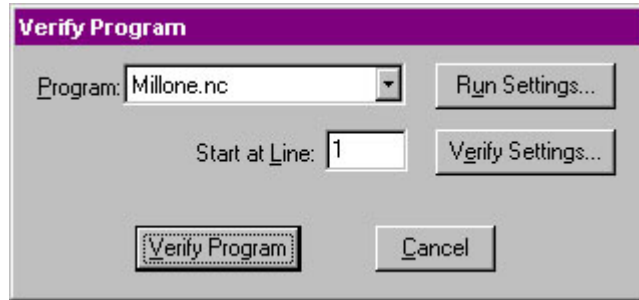

2. Click on the Verify Program button, then watch the Verify Window. You will see MILLONE.NC executed on the graphic workpiece.

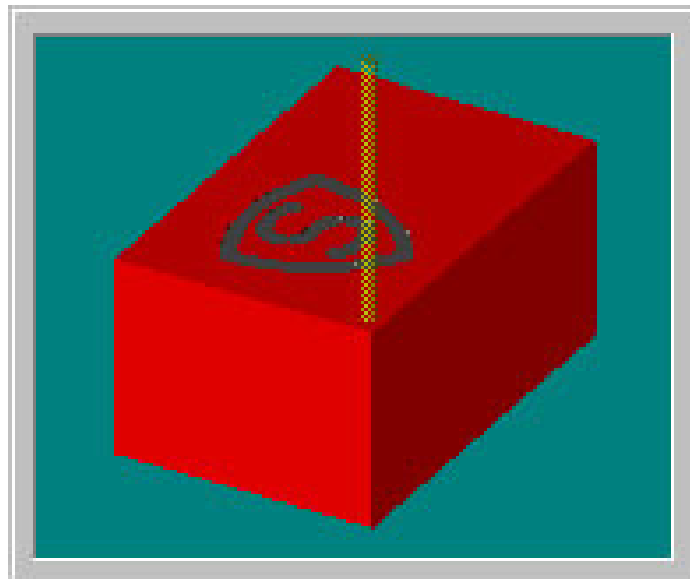

## Dry Run the NC Program

Before you run your part program for the first time, you should perform a dry run (run the program with no stock mounted) to make sure that all the movements of the machining center make sense and that the tool is in no danger of striking any fixtures or crashing into the cross slide. Although the program should be run with no stock mounted, you should set the point of origin using the workpiece, and then remove it.

**Note:** To turn the spindle speed down, select the Operator Panel, and adjust the spindle speed to 0%. As the program runs you may want to increase the speed.

Begin with the Emergency Stop button pressed in, and the spindle speed turned all the way down. The vise or other work holding device should be mounted to the cross slide and the tool should be mounted in the spindle.

1. Mount the workpiece in the vise.
2. Close the Safety Shield and pull out the Emergency Stop button.
3. Select Jog Control from the View Menu (or the Standard Toolbar). The Jog Keypad appears.

To jog the tool:

Click on the appropriate axis buttons on the Jog Keypad.

The tool moves at the speed and distance selected using the Speed and Step buttons.

The Speeds and Steps (distances) on the Jog Keypad are defined by the Setup Jog Parameters command under the Machine Menu.

To move the tool in a continuous motion, select Cont. The tool will continue to move as long as the axis button is depressed.

**Note:** Double-clicking on the Jog Keypad opens the Jog Parameters dialog box.

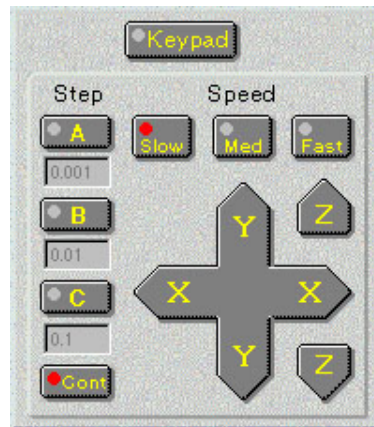

4. Use the Jog Keypad to jog the spindle to the top of the left front corner of the workpiece.
5. Select Set Position from the Setup Menu. The Set Position dialog box appears.
6. Enter zero in the X, Y and Z boxes.

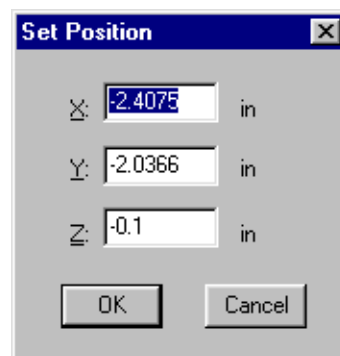

- Click on OK. The values in the Position Readout all change to zero.

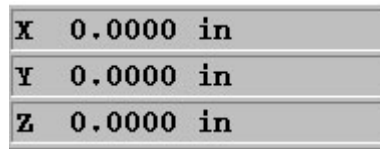

- Jog the tool up and away from the workpiece.
- Press the Emergency Stop button, open the safety shield and remove the workpiece.
- Return the Safety Shield to the closed position and pull out the Emergency Stop button.
- Put on a pair of safety glasses and complete the Safety Checklist (refer to Reference Guide: Section J.)
- Select Run/Continue from the Program Menu. The Run Program dialog box appears.

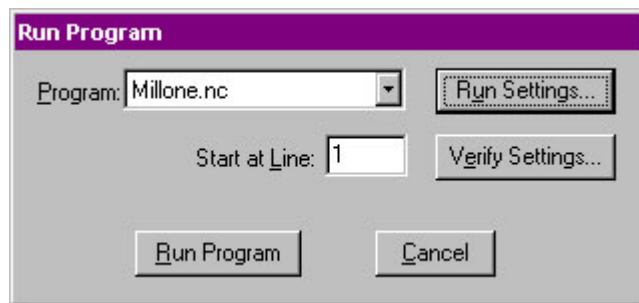

- Click on the Run Program button.
- As the part program runs, observe the tool motion in relation to the vise (and eventually the workpiece). Look for signs of a possible tool crash and be prepared to press the Emergency Stop switch on the machining center. Edit and re-verify the program as required. When you are satisfied that the tool motions are correct, you can mount the workpiece.



---

## Mount the Workpiece

1. Using the Jog Keypad, jog the spindle up and out of the way.
2. Before mounting the workpiece, push the Emergency Stop button in.
3. Mount the workpiece in the vise leaving at least 1/8" of the stock above the jaws of the vise. Take care to position the workpiece parallel to the tool bed. To assure that the piece is flat, place parallel bars underneath to space it upwards within the vise before clamping.
4. Pull the Emergency Stop button out.
5. Select the Operator Panel and check that the spindle speed is set to 100%.

The workpiece is now correctly mounted.

---

## Run the Program

Before executing the MILLONE.NC program, make certain that all safety precautions have been taken. The machining center safety shield should be closed, and you should be wearing safety glasses.

If anything goes wrong, immediately press the Emergency Stop button on the machining center to stop the operation. A safety checklist has been provided in the Reference Guide: Section J of this guide. Post a copy of this checklist near the machining center and review it before you run any NC program.

To run the program:

1. After reviewing the Safety Checklist, select the Run/Continue command from the Program Menu. The Run Program dialog box appears.

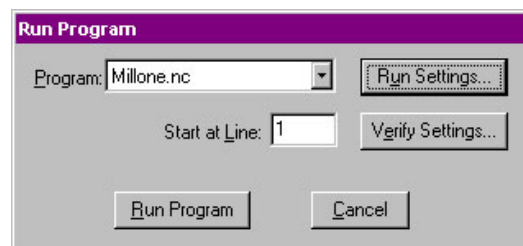

2. Make sure that the Start Line box is set to line 1 of the program.

To change the Run Settings, click on an item checkbox. The Run Settings include:

**Single Step**

Allows you to run the NC part program one line at a time

**Optional Skip**

Recognizes the optional skip code (/)

**Optional Stop**

Pauses the NC program at any M01 code

**Enable Subprograms**

Executes any subprograms embedded in the main program

**Arc Centers Incremental**

Recognizes the % code indicating that the center of an arc is an incremental value relative to the start of the arc

**Treat Warnings as Errors**

Halts the NC program at a warning as though it were an error

**Restore Unit Mode When Done**

Restores the original unit mode (inches or metric) regardless of the units used in the current NC program

**Verify While Running**

Allows tool path verification to occur while the NC program is running.

3. Click on the Run Settings button. The Run Settings dialog box appears.

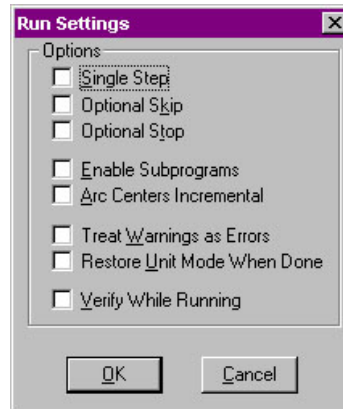

4. Make any changes desired in the Run Settings dialog box, then select OK.
5. Click on the Run Program button in the Run Program dialog box to begin running your program.
6. After the part is machined, press the Emergency Stop button before opening the safety shield and removing the finished part.

# Control Program Reference

**The BENCHMAN 4000 Interface**

**Using the Message Bar**

**Using Windows**

**Using Toolbars**

**Using Panels**

**Using the Status Bar**

**Using the Menu Bar**

**Selecting Commands**

**Positioning Screen Components**

**Using the Offset Table**

**Working in Simulation Mode**

# The BENCHMAN 4000 Interface

The BENCHMAN 4000 interface (the screen) is composed of several components that allow you to create NC part programs and interact with the machining center. The interface is easily configured and optimized by opening, closing, resizing and repositioning the screen components.

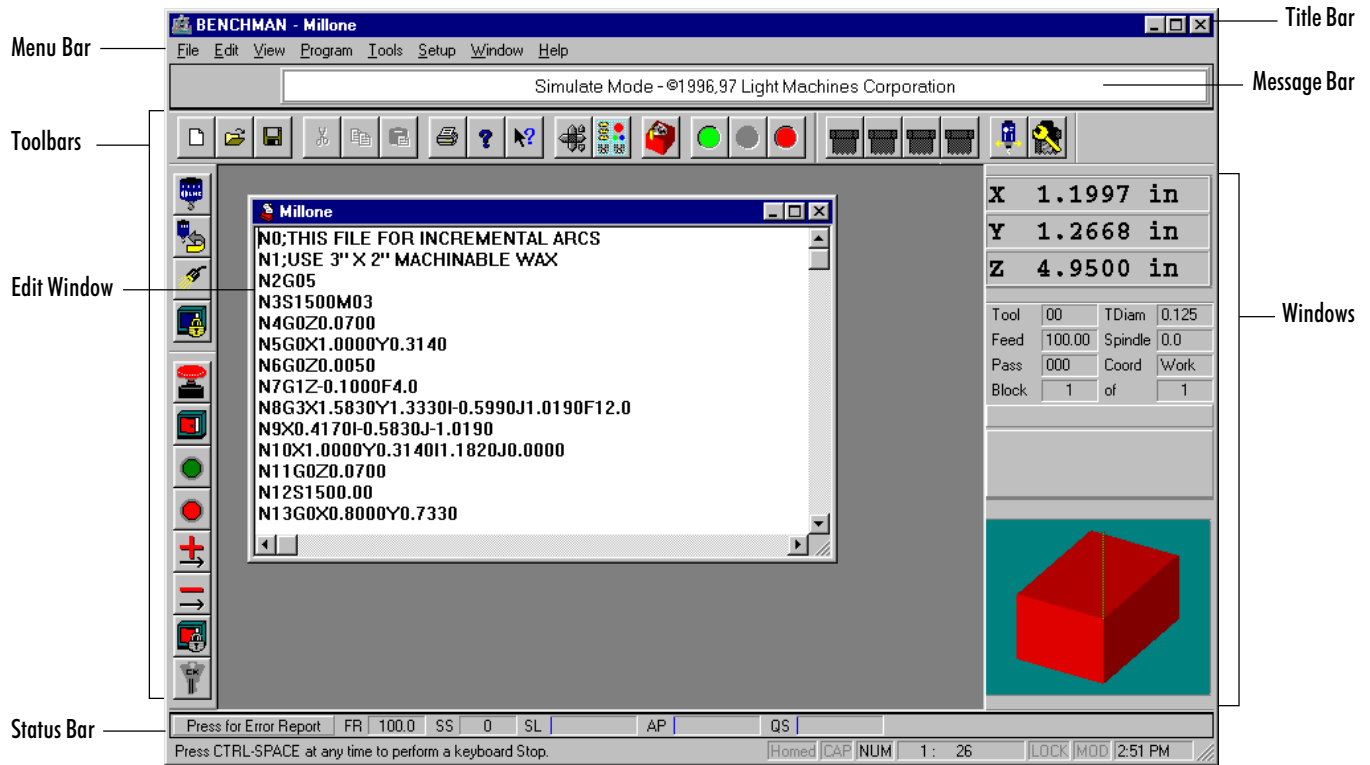

---

## Using the Message Bar

The Message Bar is located directly beneath the Menu Bar. When an NC program is running or being verified, the Message Bar displays the operation and the name of the program being run or verified, or the most recent operator message. When the program pauses for any reason (i.e. a programmed stop or an operator requested pause), the Message Bar displays a message (Operator Requested Stop; Change Tool; etc), a green Continue Program and a red Stop Program button. When there is no program running, the Message Bar displays the Control Program copyright notice.

---

## Using Windows

Windows are used to display information. Windows can be docked or they can be floating windows. They are activated or hidden using the commands under the View Menu. Windows can be interactive, or for information display only.

The following windows are available:

- ◆ Program Edit Windows
- ◆ Verify Window
- ◆ Machine Info Window
- ◆ Position Window

---

## Program Edit Windows

When you open an existing NC part program file, or create a new one, the program appears in a program edit window. Program Edit Windows have all of the features common to other windows, including a title bar which displays the program file name, and controls for minimizing, maximizing, and closing the window.

Program Edit Windows appear in the Edit Area (the large central area) of the screen. The Edit Area is fixed in position; you cannot close it or move it, and can contain multiple Program Edit Windows. The Windows Menu has several commands for managing Program Edit Windows. It also allows you to select a particular window from a list of all current program windows, identified by file names.

When other windows, panels, and toolbars are **closed**, the space that their docking areas occupy is given to the Edit Area.

When other windows, panels, and toolbars are **open**, the space that their docking areas occupy is taken from the Edit Area.

Tips:

- ◆ You can double-click on the Verify Window to bring up the Verify Setup dialog box.
- ◆ You can move the Verify Window to another part of the screen by holding the Ctrl key down, then clicking and dragging the Window.
- ◆ Pressing the right mouse key while in the Verify window displays a pop-up menu with Verify-related commands.
- ◆ When the Verify Window is floating (not docked) you can resize it just like any other window. To keep the Verify window as a floating window, right-click on the window and uncheck the "dockable" command.

Tips:

- ◆ You can move the Machine Info Window to another part of the screen. Hold the Ctrl key down, then click and drag the Machine Info Window.
- ◆ Clicking the right mouse key over the Machine Info Window displays a pop-up menu with the Dockable and Hide commands.
- ◆ When the Machine Info Window is floating (not docked) you can resize it just like any other window. To keep the window as a floating window, right-click on the window and uncheck the "dockable" command.

## The Verify Window

The Verify Window can be opened and closed by selecting the Verify Window command from the View Menu.

The Verify Window displays a simulation of your part program (tool path verification) when you select the Verify command from the Program Menu, or when you click the Verify Program button on the Standard Toolbar.

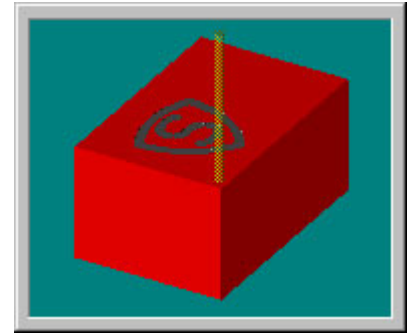

Tool path verification can be performed in centerline view or solid view. Centerline view is based on the centerline of the tool. Solid view is a solid representation of the tool and workpiece.

## The Machine Info Window

The information displayed in the Machine Info Window varies with the particular operation being performed:

**When the machine is idle**, the Machine Info Window displays the following information:

- ◆ Current tool number and diameter
- ◆ Feed rate and spindle speed
- ◆ Number of passes made for the current program
- ◆ Coordinate system being used
- ◆ Current block number and the number of blocks in the current program.

The passes, current block, and total number of blocks refer to the last program verified or run.

Tool	11	TDiam	0.125
Feed	10.00	Spindle	1500.0
Pass	001	Coord	VWork
Block	5	of	20

When a program is running, the Machine Info Window becomes a dynamic display. In addition to updating the previously mentioned information, each line of code is displayed as it is executed, along with the previous and next lines of code. Also, a clock provides the elapsed run time for the program.

Tool	11	TDiam	0.125
Feed	*RAPID*	Spindle	1500.0
Pass	001	Coord	Work
Block	2	of	20
Part Time 00:13			
1 N0G0Z.1;RAPID TOOL AWAY FROM STOCK			
2 N1G90X.417Y1.333;MOVE TO START POINT			
3 N2S1500M3;SPINDLE ON			

When a program is being verified, the Machine Info Window displays the current line of code, plus the previous and next lines. The elapsed time is not indicated.

Tool	11	TDiam	0.125
Feed	10.00	Spindle	1500.0
Pass	001	Coord	Work
Block	20	of	20
19 N18X0Y0;MOVE TOOL BACK TO START			
20 N19M2;END OF PROGRAM			

## The Position Window

**Note:** When running the Control Program in Simulate mode, the Goto command will not move the machine to the specified coordinates. It will simulate movement, showing the tool moving to those coordinates in the Position Window, and the Verify Window.

This is a dynamic display. When a program is running or being verified, the current position of the tool is indicated here.

If you double-click on this window, the Goto Position dialog box appears, allowing you to move the tool to specific coordinates.

<b>X</b>	<b>0.0000 in</b>
<b>Y</b>	<b>0.0000 in</b>
<b>Z</b>	<b>0.1000 in</b>

# Using Toolbars

Toolbars carry buttons that correspond to frequently used menu commands. You can click on these buttons to quickly select the associated menu command. Toolbars also generate Outputs and display the state of Inputs. Toolbars can be placed anywhere on your screen, and can be hidden if you do not use them often or want the additional space for program windows. Toolbars are revealed and hidden using the Toolbars command under the View Menu.

The toolbars include:

- ◆ Standard Toolbar
- ◆ Outputs Toolbar
- ◆ Inputs Toolbar
- ◆ ATC Control Toolbar

## The Standard Toolbar

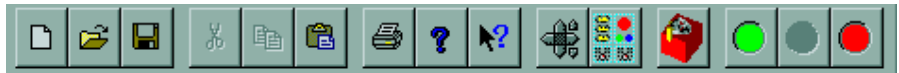

The Standard Toolbar provides quick-access buttons for the following:

Command:	Used to:
New File	Create a new program edit window
Open File	Open an existing NC program file
Save File	Save an NC program file
Cut	Cut text from a program
Copy	Copy text from a program
Paste	Paste text into a program
Print	Print an NC program
Help	Access Help
Context Help	This button can help you instantly find information on the objects you see on the screen. For instance, click on the Context Help button, then click on a menu item, toolbar button, window or other screen element. The Help file for that particular item appears.
Jog Control Panel	Show or hide the Jog Control Panel

### Context-Sensitive

The results of your action are dependent on the item you click, or on the operation you are currently performing.



<b>Operator Panel</b>	Show or hide the Operator Panel
<b>Verify</b>	Verify the current NC part program
<b>Run</b>	Run the current NC part program
<b>Pause</b>	Pause the currently running NC part program
<b>Stop</b>	Immediately halt the currently running NC program

## The ATC Control Toolbar



This toolbar is only available if your machine is equipped with an Automatic Tool Changer. The Automatic Tool Changer Toolbar provides quick-access buttons for automatically changing tools. The toolbar provides six buttons; one for each tool station, one to clamp and unclamp the drawbar, and one to open the Configure ATC dialog box.

The Tool station buttons are numbered from left to right, 1 through 4. Each tool station button displays the number of the tool currently assigned to that particular station.

## The Inputs Toolbar



The Inputs Toolbar isn't really a toolbar in the sense that it is not used to interact with the various Control Program inputs. It is a monitoring device that keeps track of the state of the various system inputs.

The state of each input is indicated by the position of its button. If a button is depressed, the input is "on" or "high." If a button is not depressed, the input is "off" or "low." You can also check the condition of an input by clicking on it, or by holding the mouse over the input button. The state of the input is displayed on the Status Bar at the bottom of the screen.

**The inputs on the Inputs Toolbar include:**

- ◆ The **Emergency Stop** condition. This input is in the "on" condition (depressed) if the Emergency Stop button on the machining center is pushed in.
- ◆ The **Safety Shield** condition. This input is in the "on" condition (depressed) if the Safety Shield on the machining center is open.
- ◆ The **Cycle Start** condition. This input is in the "on" condition (program has begun) when the button is depressed.
- ◆ The **Cycle Stop** condition. This input is in the "on" condition (program is being stopped) when the button is depressed.

- ◆ The **Positive Limit** condition. This input is in the “on” condition (depressed) if one of the positive axis limits has been hit.
- ◆ The **Negative Limit** condition. This input is in the “on” condition (depressed) if one of the negative axis limits has been hit.
- ◆ The **Door Lock** condition. This input is in the “on” condition (depressed) if the door is locked.
- ◆ The **Machine Keylock** condition. This input is in the “on” condition (depressed) if the machine key lock is in the locked position.

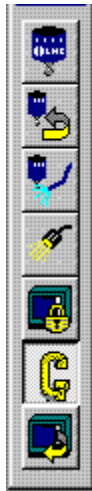

Note: The Spindle and Spindle Direction buttons do not have the same effect as the M03 and M04 codes in an NC program. For more information about these codes, see Section F, Basic CNC Programming.

## The Outputs Toolbar

The Outputs Toolbar provides quick-access buttons for controlling the system outputs. Depending on the options configuration of your machine, the Outputs toolbar may have more buttons on it than the one shown here.

The state of each output is indicated by the position of its button. If a button is depressed, the output is “on” or “high.” If a button is not depressed, the output is “off” or “low.” You can also check the condition of an output by holding the cursor over the button. Clicking on the button will change the state of the output. The state of the output is displayed on the Status Bar at the bottom of the screen.

The output controls on the Outputs Toolbar include:

- ◆ The **Spindle** control. This button turns the spindle on and off.
- ◆ The **Spindle Direction** control. This button reverses spindle direction.
- ◆ The **Coolant** control. This button turns the flow of coolant to the workpiece on and off.
- ◆ The **Light** control. This button turns the light on and off.
- ◆ The **Door Lock** control. This button latches and unlatches the door lock.
- ◆ The **Air Vise** control. This button activates and deactivates the optional air vise.
- ◆ The pneumatic **Door Opener** control. Selecting this button allows you to activate the optional pneumatic door opener.
- ◆ The **General Pneumatic Device** control (not shown). This button controls any other pneumatic device you have installed on the machine.

# Using Panels

The Jog Control Panel and the Operator Panel are used to control machine operation.

### Tips:

- ◆ Double-clicking on the Jog Control Panel opens the Jog Settings dialog box.
- ◆ If you wish, you can move the Jog Control Panel to another part of the screen by holding the Ctrl key down, then clicking and dragging the Jog Control Panel.
- ◆ Select the keypad button if you wish to use the numeric keypad on your computer keypad for jogging.

## The Jog Control Panel

The Jog Control Panel is accessed by selecting the Jog Control command under the View Menu, or by clicking on the Jog Control button on the Standard Toolbar. The Jog Control Panel allows you to manually move (jog) the tool on the machining center. Selecting the Keypad button allows you to use the numeric keypad on the keyboard to jog the machine.

Each axis on the machine is represented by buttons. The X and Y axes are represented by the crosspad. The crosspad follows the Cartesian coordinate system standard; -X to +X is left to right, while -Y to +Y is front to back. The Z axis is represented by two buttons, one for positive motion (up) and one for negative motion (down). Pressing any of the axis buttons moves the tool in the indicated direction.

Jogging occurs in specific increments of speed and distance. The speed and distance values are selected on this panel as well. You can alter the speed and distance parameters for jogging by selecting the Jog Settings command under the Setup Menu, or by double clicking on the Jog Control Panel.

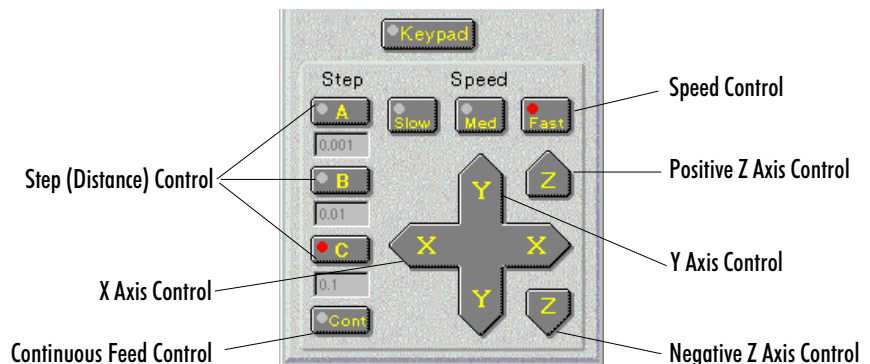

Note: To move the tool in a continuous motion, select Cont. The tool will continue to move as long as the axis button is depressed.

### To jog a tool:

1. Define the Speeds and Steps (distances) for jogging by selecting the **Jog Settings** command under the Setup Menu.
2. Click on the **Axis** button on the Jog Keypad to move the tool in the desired direction. The tool moves at the speed and distance indicated by the Speed and Step buttons.

**Tip:**

You can move the Operator Panel to another part of the screen by holding the Ctrl key down, then clicking and dragging the Operator Panel.

## The Operator Panel

The Operator Panel provides controls that are used while running an NC program on the machining center.

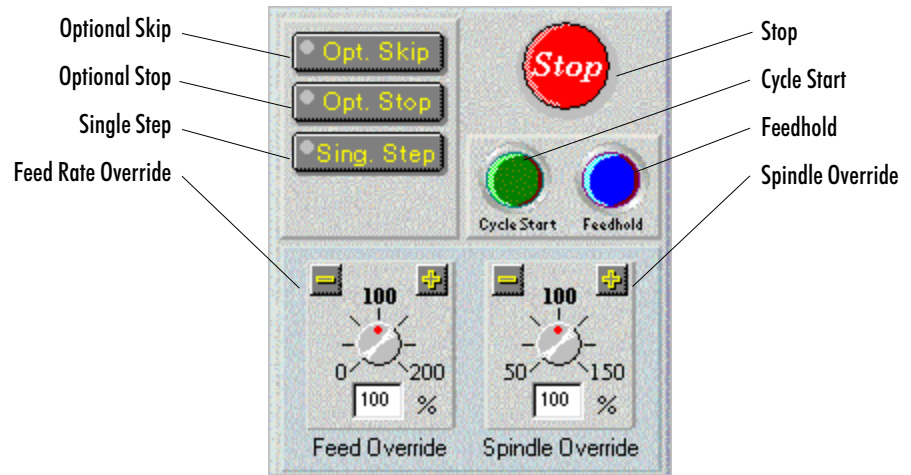

### The Operator Panel controls include:

- ◆ **Optional Skip:** Allows you to **execute or ignore** any optional skips ( / codes) you have embedded in the NC program.
- ◆ **Optional Stop:** Allows you to **execute or ignore** any optional stops (M01 codes) you have embedded in the NC program.
- ◆ **Single Step:** Causes the NC program to pause after each block is executed. This allows you to check each step of the cutting operation. Single Step is particularly useful after changing the workpiece size.
- ◆ **Stop:** Immediately halts the currently running NC program. This button works the same as the Ctrl + Space Bar combination.
- ◆ **Cycle Start:** Begins running the current NC program from the beginning or from a paused condition.
- ◆ **Feedhold:** Pauses the currently running NC program. To continue running the program from a Feedhold, press the Feedhold button again or press the Cycle Start button.
- ◆ **Feed Rate Override:** Overrides the programmed feed rate.
- ◆ **Spindle Speed Override:** Overrides the programmed spindle speed.

---

### IMPORTANT!

---

Always use the Emergency Stop Button in an emergency situation. It is the best way to stop the machine.

## Using the Status Bar

The Status Bar displays various information about the machining center and the computer. The top of the bar shows information about the machine while the bottom displays NC program information, and the time. The top left side of the Status Bar displays any current machine error conditions. The bottom left side of the Status Bar displays operator messages such as the one shown here. If any of the areas are grayed-out, the feature is considered off.

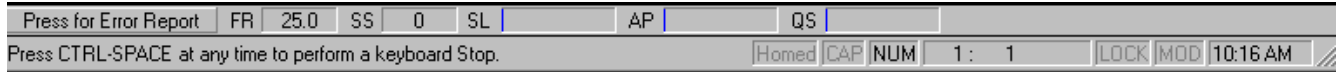

- ◆ **Machine Error Conditions:** When an error is generated, the message area flashes red, and displays a letter designating the error. Click on the message area for the error details.
- ◆ **FR:** Current Machine Feed Rate. This displays the actual feed rate, taking into consideration the programmed feed rate, and any overrides set on the front panel or the Operator Panel on the screen.
- ◆ **SS:** Current Spindle Speed. This displays the actual spindle speed, taking into consideration the programmed spindle speed, and any overrides set on the front panel or the Operator Panel on the screen.
- ◆ **SL:** Spindle Load; current load on the spindle.
- ◆ **AP:** Relative ATC air pressure. If the pressure drops below the safe operating level (75 psi), the display will turn red.
- ◆ **QS:** Queue Status, or percentage of queue (buffer space on the Motion Control Card) currently in use.
- ◆ **Operator Messages:** Displays general machine messages.
- ◆ The **Machine Homed** state: Black if the machine is currently homed.
- ◆ The **Caps Lock** key state: Black if the Caps Lock feature is on. Some NC programmers prefer to type their programs in capital letters. When the Caps Lock feature is on anything you type will be displayed in capital letters. Press the Shift key to type lower case letters.
- ◆ The **Num Lock** key state: Black if the Num Lock feature is on. Some NC programmers prefer to use the numeric keypad on the keyboard to enter figures. The Num Lock feature must be on to do this.
- ◆ **Current Line: Total Lines:** Displays the line the cursor is currently on, and the total number of lines in the NC program.
- ◆ The **File Locking** state: Black if the NC program file is locked.
- ◆ The **File Modified** state: Black if the NC program has been modified since being opened.
- ◆ The current time (according to your computer).

---

## Using the Menu Bar

The Menu Bar is located at the very top of the screen. It lists the categories of commands into which the Control Program operations are grouped.

The available menus are:

- ◆ The File Menu
- ◆ The Edit Menu
- ◆ The View Menu
- ◆ The Program Menu
- ◆ The Tools Menu
- ◆ The Setup Menu
- ◆ The Window Menu
- ◆ The Help Menu

---

## File Menu

The File Menu provides typical file management commands and the Exit command.

<b>Command:</b>	<b>Used to:</b>
New	Create a new program window.
Open	Open an existing file.
Close	Close an open program window.
Save	Save a program.
Save As	Save a program under a different filename or location.
Print	Print an open NC program.
Print Setup	Set up your printer for printing.
Recent files	Open one of the eight most recently used files.
Exit	Exit the Control Program.

## New Command

Use the New command under the File Menu to create a new program edit window.

You can create a new program edit window at any time. The number of program edit windows that you have open at one time is limited by the amount of memory on your computer.

To create a new program window, select **New** from the File Menu, or press **Ctrl+N**.

A new program window is created. The filename on the Title Bar is “Untitled,” indicating that this is a new program. The program will remain untitled until you save it. You should save your new programs before they are run or verified.

## Open Command

Use the Open command under the File Menu to open an existing NC program. The number of program edit windows that you have open at one time is limited by the amount of memory on your computer.

**To open an existing NC program:**

1. Select **Open** from the File Menu, or press **Ctrl+O**. The Open dialog box appears.
2. In the dialog box, locate and highlight the desired NC file.
3. Click the **Open** button or press **Enter**. The selected NC program file is opened. The Title Bar displays the name of the file.

**To select a file that is already open:**

- ◆ If the open file has changed since it was opened, you are prompted to reload the original version of the file or to cancel the opening procedure.
- ◆ If the open file has not changed since it was opened, it becomes the active Program Edit Window.

## Close Command

You can close a program window that is not running, at any time. Unless you have already done so, you will be prompted to save any changes made to the program file.

**To close a program window:**

1. Make sure the program window you want to close is selected.
2. Select one of several ways to close the open window:
  - ◆ Select the **Close** command from the File Menu.
  - ◆ Single-click the icon on the far left of the Title Bar, and select **Close** from the drop-down menu. (If the edit window is maximized, this icon will be in the far left of the Menu Bar.)
  - ◆ Double-click the icon on the far left of the Title Bar. (If the edit window is maximized, this icon will be in the far left of the Menu Bar.)
  - ◆ Click on the **Close** button on the far right of the Title Bar. (If the edit window is maximized, this icon will be in the far right of the Menu Bar.)
  - ◆ Press **Ctrl+F4**.

**Tip:**

If you enable the AutoSave feature, your work will be saved automatically at regular intervals. Use of the AutoSave feature is recommended; if AutoSave is not enabled, you should save your files frequently as you work. For more information, see the Preferences selection under the Setup Menu.

3. If there are unsaved changes to the current program, the File Save dialog box appears, prompting you to save the changes. Click one of the buttons in the dialog box:
  - ◆ Click **Yes** to save the changes.
  - ◆ Click **No** to discard the changes.
  - ◆ Click **Cancel** to exit the dialog box without saving the changes or closing the program window.

## Save Command

Use the Save command under the File Menu to save the current program as an NC file.

If the current NC program was previously saved, selecting Save saves the changes to the same file. If the current program is new (and still has the name “Untitled”), selecting Save brings up the Save As dialog box, in which you name, choose a location for, and save the new program.

To save a program, select **Save** from the File Menu, or press **Ctrl+S**.

The current program is saved to a file. If this is a new program, the Save File As dialog box appears. Choose a name and location for the new file.

## Save As ... Command

Use the Save As command under the File Menu to save the current program to an NC file using a new name or location.

### Save As Dialog Box

The Save As dialog box is the same in the Control Program as in other Windows applications.

**To use the Save As dialog box:**

1. Select a destination for the file using the **Save in:**, **Up one level** and **Create new folder** buttons.
2. Enter a filename in the **File Name:** field.
3. Select a file type in the **Save as type:** field.
4. Click **OK** or press **Enter** to save the file.
5. Click **Cancel** or press **Esc** to cancel and exit the dialog box.

**Note:** When you name a file, consider whether this file will be used on older systems running DOS or Windows 3.1 before you take advantage of Windows 95 and NT long file names.



## Print Command

Use the Print command under the File menu to print the current NC program.

### To print the program:

1. Select one of the following ways to open the Print dialog box:
  - ◆ Click the **Print** button on the toolbar.
  - ◆ Select the **Print** command from the File Menu.
  - ◆ Press **Ctrl+P**.

The Print dialog box appears.

2. Choose the desired print options in the dialog box. Clicking **Setup** opens the Print Setup dialog box.
3. Click **OK** to print, or click **Cancel** to exit the Print dialog box without printing the NC program.

You can print to any printer that is supported by Windows 95. See your printer manual or Windows documentation for more information on installing and using printers with Windows.

## Print Setup Command

Use the Print Setup command under the File Menu to select a printer. The Print Setup dialog box allows you to establish parameters for printing your NC part programs.

### To choose print settings:

1. Select **Print Setup** from the File Menu. The Print Setup dialog box appears.
2. Select the desired print settings, including:
  - ◆ The destination printer.
  - ◆ The size of the paper.
  - ◆ The paper tray.
  - ◆ The orientation of the paper.
3. Click **OK** to print, or click **Cancel** to exit the Print dialog box without setting the printing parameters.

## Opening a Recent Program

You can use the numeric (1, 2, 3, ... 8) commands under the File Menu to open any of the eight most recently opened files.

The names and paths of the eight most recent files appear as file 1 (the file last opened) through file 8 (the eighth most recent).

### To open one of the eight most recently opened programs:

Select 1, 2, 3, 4, 5, 6, 7 or 8 from the File menu.

The recent program you selected is opened. The Title Bar displays the name of the program file.

## Exit Command

Use the Exit command under the File Menu to exit the Control Program. You should always exit the Control Program before you exit Windows.

Use one of the following options to exit the Control Program:

- ◆ Select the **Exit** command from the File Menu.
- ◆ Single-click the icon on the far left of the Control Program Title Bar. Select **Close** from the drop-down menu.
- ◆ Double-click the icon on the far left of the Control Program Title Bar.
- ◆ Click on the **Close** button on the far right of the Title Bar.
- ◆ Press **Alt+F4**.

If there are unsaved changes to any program window, a dialog box appears for each unsaved program window, prompting you to save the changes.

- ◆ Click **Yes** to save the changes and exit.
- ◆ Click **No** to ignore the changes and exit.
- ◆ Click **Cancel** or press **Esc** to cancel the Exit command and return to the Control Program.

## Edit Menu

### Selecting Text

Use the mouse or a Shift+Arrow key combination to select a portion of your NC program for cutting, pasting, or copying.

To select text using the editing keys:

1. Using the arrow keys, position the cursor at the beginning of the text to be selected.
2. Press the shift key and hold it down while using the arrow keys to move the cursor to the end of the text to be selected.
3. Release the shift key.

To select text using the mouse:

1. Place the cursor at the beginning of the text to be selected.
2. Click and hold the left mouse button.
3. Move the cursor to the other end of the text to be selected.
4. Release the mouse button.

The Edit Menu provides typical text editing commands.

Command:	Used to:
<b>Undo</b>	Undo the most recent editing command.
<b>Redo</b>	Redo the last undo command.
<b>Cut</b>	Cut selected text to the Windows clipboard.
<b>Copy</b>	Copy selected text to the Windows clipboard.
<b>Paste</b>	Paste text from the Windows clipboard into the current NC program.
<b>Clear</b>	Delete selected text.
<b>Delete Line</b>	Delete the line the cursor is currently on.
<b>Find</b>	Locate a sequence of characters in an NC program.
<b>Replace</b>	Replace one sequence of characters with another, one or more times.
<b>Goto Line</b>	Jump to a particular line in the NC program.
<b>Renumber</b>	Modify or insert N codes in an NC program .
<b>Lock</b>	Lock or unlock the Program Edit Window to prevent or allow modification to the NC program.
<b>Select Font</b>	Change the font currently being used.

## Undo Command

The Undo command reverses the most recent editing action taken. It is useful for recovering from accidental deletion or inclusion of a block of text.

To undo the last change, select **Undo** from the Edit menu, or press **Ctrl+Z**.

- ◆ If your last editing action was to delete selected text, the text is restored.
- ◆ If your last editing action was to delete a character, the character is restored.
- ◆ If your last editing action was to paste text, the text is removed.
- ◆ If your last editing action was to type a character, the character is removed.
- ◆ If Undo is grayed-out in the Edit menu, no changes can be undone.

## Redo Command

The Redo command reverses the action of the undo command. If you deleted a part of the text, and then decided to undo that deletion, the Redo command will perform the original delete again.

## Cut Command

Use the Cut command under the Edit Menu to remove text from the NC program (the text is copied to the Windows clipboard). The text can then be pasted anywhere in the current program, into another program, or into another application such as Notepad. The text remains in the Windows clipboard until it is replaced by another Cut or Copy operation.

### To cut text to the Clipboard:

1. Select the text you wish to cut.
2. Select **Cut** from the Edit Menu, or press **Ctrl+X**.

## Copy Command

Use the Copy command under the Edit Menu to duplicate selected text in an NC program.

### To copy text to the Clipboard:

1. Select the text you wish to copy.
2. Select **Copy** from the Edit Menu, or press **Ctrl+C**. The selected text is copied to the Clipboard.

## Paste Command

Use the Paste command to insert text from the Windows clipboard into your NC program.

### To paste text from the Clipboard:

1. Place the cursor at the point in the NC program where you wish to insert text that has been previously cut or copied to the Windows clipboard.
2. Select **Paste** from the Edit menu, or press **Ctrl+V**. The contents of the clipboard are inserted into the program. If this menu command is grayed-out, there is no text on the clipboard to paste.

## Clear Command

Use the Clear command under the Edit Menu to delete selected text from your NC program. The text is not copied to the Windows clipboard. You can also use the Delete key on your keyboard to achieve the same effect.

**To delete text using the Clear command:**

1. Select the text you wish to delete.
2. Select the Clear command from the Edit Menu. The selected text is deleted.

## Delete Line Command

Use the Delete Line command under the Edit Menu to delete an entire line of NC code from a program without selecting it first.

**To delete a program line using the Delete Line command:**

1. Place the cursor anywhere on the line of code you wish to delete.
2. Select the **Delete Line** command from the Edit Menu, or press F2. The line of code is deleted.

## Find Command

Use the Find command under the Edit Menu to locate a particular sequence of characters within an NC program.

**To use the Find command:**

1. Select **Find** from the Edit Menu, or press **Ctrl+F**.
2. Enter the character sequence you are looking for in the **Find:** box.
3. Select the **Match Case** box to restrict the search to finding only those text strings that match the case (upper or lower) of the text that you entered.
4. Select **Up** or **Down** from the Direction box to search through the text before or after the cursor position, respectively.
5. Click **Find Next** or press **Alt+S** to begin the search. Click **Cancel** or press **ESC** to exit the Find dialog box without performing the search.

To find the same character string again, use the **Find Next** button.

## Replace Command

Use the Replace command under the Edit Menu to replace an existing character string with a new character string.

**To use the Replace command:**

1. Select **Replace** from the **Edit Menu**.
2. Enter the existing character string in the **Find What:** box.
3. Enter the new character string in the **Replace With:** box.
4. If you select **Match whole word only** the program will only find and replace text that matches your entry. When you select **Match case**, it will find and replace those text strings that match the case (upper or lower) of the text you entered.
5. Select one of the buttons depending on how you wish to replace text.
  - ◆ **Find Next** will find the next occurrence of the text.
  - ◆ **Replace** will replace the selected text with the new text.
  - ◆ **Replace All** will replace all occurrences of the text with the new text.
  - ◆ **Close** will close the dialog box.

## Goto Line Command

Use the Goto Line command under the Edit Menu to move the cursor to a specific line in the NC program. This command is also available using the Program Edit Window Pop-up Menu.

**To use the Goto Line command:**

1. Select **Goto Line** from the Edit Menu, or press **Ctrl+G**. The Goto Line dialog box appears.
2. Enter a line number in the Jump To Line box. The cursor moves to the specified line. If the line number entered is larger than the number of lines in the program, the cursor is moved to the end of the program.

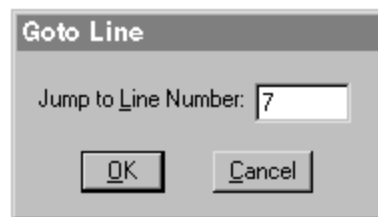

**Note:** The Goto Line Command will not jump to an N code number; use the Find Command for that operation.

## Renumber Command

**Note:** The Undo command will not undo the effects of the Renumber command. Removed comments must be re-entered manually. You should save a copy of the program to another file using the Save As command so you can easily recover if the effects of using Renumber are not what you expected.

Use the Renumber command under the Edit Menu to alter the N codes in your NC program.

The Renumber command can be used to:

- ◆ Insert N codes in a program that doesn't have any.
- ◆ Remove N codes from a program.
- ◆ Renumber the N codes in a program.
- ◆ Insert, remove or ignore spaces between NC commands.
- ◆ Remove comments from the program.

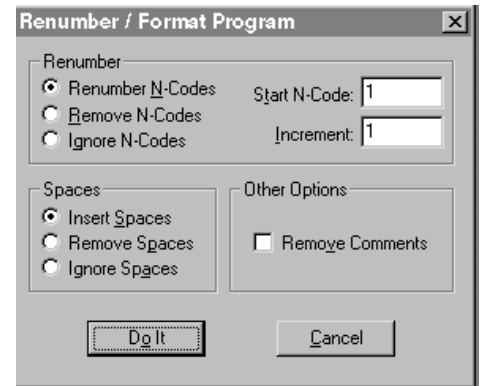

### Insert N Codes

To insert or renumber the N codes in your program:

1. Select **Renumber** from the Edit Menu. The Renumber/Format Program dialog box appears.
2. Select **Renumber N Codes** or press **Alt+N**.
3. Click on the **Start N Code** box (or press **Alt+T**), then enter the number of the first N code. The default starting block number is N1.
4. Click on the **Increment** box (or press **Alt+I**), then enter the increment you wish to use.

For instance, if you wish to have each N code numbered in increments of 5, enter 5 in the Start N Code box and enter 5 in the Increment box. The N code sequence will then be: N5, N10, N15, N20...and so on.

This option is useful if you are renumbering a portion of the program to be inserted into another program. Using increments greater than 1 allows you to insert additional numbered lines without having to renumber the whole program.

5. Select **Do It**, or press **Alt+O**, to execute the Renumbering options you selected. Select **Cancel**, press **Alt+C**, or press **Esc**, to exit the Renumber/Format Program dialog box without altering the NC program.

## Renumbering and Subprograms

**Note:** The number of a line in a program and the number of the corresponding N-code are only the same if the first N code in the program is N1 and each N code thereafter is incremented by 1.

Although the Renumber command automatically changes P codes used with (M99) codes, it does not renumber P codes used with M98 codes, nor does it renumber O codes. Although O codes are not altered, the lines which they occupy are counted. So, the very next N code is numbered as though the O code has been renumbered, too.

For instance,    N41X...  
                  N42X...  
                  O25G...  
                  N44...

In this example, although the O code has not been renumbered, the line it resides on has been counted. The N code on the following line reflects the next number in the sequence.

## Insert or Remove Spaces

To insert or remove spaces between the NC words in your program:

1. Select **Renumber** from the Edit Menu. The Renumber/Format Program dialog box appears.
2. Choose a Spaces option.
  - ◆ **Insert Spaces** inserts a space between each NC word (to the left of the comment code).
  - ◆ **Remove Spaces** removes any spaces between NC words (to the left of the comment code).
  - ◆ **Ignore Spaces** ignores any spaces in the NC program.
3. Select **Do It**, or press **Alt+O**, to execute the Spaces options you selected. Select **Cancel**, press **Alt+C**, or press **Esc**, to exit the Renumber/Format Program dialog box without altering the NC program.



Note: The Undo command will not undo the effects of the Remove Comments command. Removed comments must be re-entered manually. You should save a copy of the program to another file using the Save As command so that you can easily recover if the effects of using Renumber are not what you expected.

Important: None of the renumber actions can be undone!

## Remove Comments

To remove comments from your program:

1. Select **Renumber** from the Edit Menu. The Renumber/Format Program dialog box appears.
2. Select **Remove Comments**.
3. Select **Do It**, or press **Alt+O**, to execute the Remove Comments command. Select **Cancel**, press **Alt+C**, or press **Esc**, to exit the Renumber/Format Program dialog box without altering the NC program.

## Remove N Codes

To remove the N codes from your program:

1. Select **Renumber** from the Edit Menu. The Renumber/Format Program dialog box appears.
2. Select **Remove N Codes** or press **Alt+R**.
3. Select **Do It**, or press **Alt+O**, to execute the Remove N Codes command. Select **Cancel**, press **Alt+C**, or press **Esc**, to exit the Renumber/Format Program dialog box without altering the NC program.

## Lock Command

Use the Lock command under the Edit Menu to prevent or allow changes to your NC programs. If a check mark appears next to this command, the current NC program is locked.

When an NC program is unlocked, it can be modified by the commands on the Edit Menu. When an NC program is locked, the program cannot be changed by any commands. By default, when you open a file it is automatically locked to prevent accidental changes. You can change this default in the preferences dialog box.

If you have Multiple Program Edit windows open, each is individually locked or unlocked. The state of the currently selected NC program, locked or unlocked, can be easily checked by looking at the Lock Indicator on the Status Bar.

To use the Lock command to lock or unlock your NC program, select **Lock** from the Edit Menu, press **Ctrl+L**, or double-click the **Lock Indicator** on the Status Bar.

## Select Font Command

Use the Select Font command under the Edit Menu to change the font settings for open NC programs. Font Settings are intended for viewing and printing purposes only. They do not affect the NC program in any way and are not stored within the program file. All open program windows use the same font settings.

To use the Select Font command:

1. Select the **Select Font** command from the **Edit** Menu.
2. Select a font from the **Font** list.
3. Select a font size from the **Size** list.
4. Click **OK** to change the font, or click **Cancel** or press **Esc** to exit the Font dialog box without changing the fonts.

Note: The Undo command does not undo a font settings change.

---

## View Menu

The View Menu commands control the display of windows and toolbars.

Command:	Used to:
<b>Position</b>	Open or close the Machine Position Window.
<b>Machine Info</b>	Open or close the Machine Info Window.
<b>Jog Control</b>	Open or close the Jog Control Panel.
<b>Operator Panel</b>	Open or close the Operator Panel.
<b>Verify Window</b>	Open or close the Verify Window.
<b>Toolbars</b>	Open or close the toolbars.

## Position Command

Use the Position command on the View Menu to open or close the Position Window.

To open or close the Position window, select **Position** from the View Menu. A check mark appears next to the Position command when the Position Window is open.

## Machine Info Command

Use the Machine Info command on the View Menu to open or close the Machine Info window.

To open or close the Machine Info window, select **Machine Info** from the View Menu. A check mark appears next to the Machine Info command when the Machine Info Window is open.

## Jog Control Command

Use the Jog Control command on the View Menu to open or close the Jog Control Panel. You can also use the Jog Control button on the Standard Toolbar.

To open or close the Jog Control window, select **Jog Control** from the View Menu. A check mark appears next to the Jog Control command when the Jog Control Panel is open.

## Operator Panel Command

Use the Operator Panel command on the View Menu to open or close the Operator Panel.

To open or close the Operator Panel, select **Operator Panel** from the View Menu. A check mark appears next to the Operator Panel command when the Operator Panel is open.

## Verify Window Command

Use the Verify Window command on the View Menu to open or close the Verify Window.

To open or close the Verify Window, select **Verify Window** from the View Menu. A check mark appears next to the Verify Window command when the Verify Window is open.

## Toolbars Command

Use the Toolbars command on the View Menu to show or hide the Toolbars.

**To show or hide a toolbar:**

1. Select **Toolbars** from the View Menu. The list of available toolbars is displayed. Toolbars that are visible have a check mark beside them.
2. Select the toolbar that you wish to show or hide.

## Program Menu

The Program Menu commands allow you to Run, Verify, or Stop an NC program.

Command:	Used to:
Run/Continue	Start running or resume running the current NC program.
Verify	Verify the current NC program.
Estimate Runtime	Estimate the runtime of the current NC program.
Pause	Pause the currently running NC program.
Feedhold	Stop movement of all axes.
Stop	Immediately halt the currently running NC program.

---

### CAUTION

---

*Always wear safety glasses and close the safety shield before running an NC program on the machining center. Always observe set up and safety precautions.*

## Run/Continue Command

The Run/Continue command under the Program Menu runs the **currently selected** NC program on the Machining Center. When you select Run/Continue from the Program Menu, the Run Program dialog box appears, allowing you to select the program, the start block, run settings, and verify settings.

The Run Program dialog box allows you to select an NC program to run, to set the line from which to begin running the program, and to access the Run Settings and Verify Settings dialog boxes.

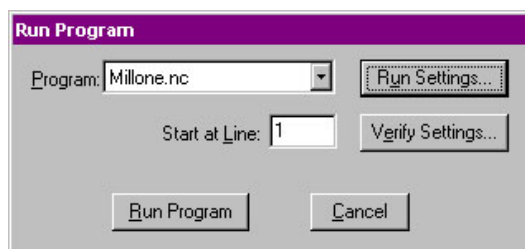

1. Select an NC Program.

If you have more than one NC program open, use the **Program** drop-down list, or press **Alt+P**, to select the program you wish to run.

2. Select a starting line.

When you are running an NC program for the first time, it is wise to start the program from the first line. When you start at a line other than one, the control program parses through the program to the specified start point. As it parses, it performs operations such as turning the spindle on, but it will not execute a Dwell or Pause command, and it will not move the tool.

To specify a starting line, click on the **Start at Line** box, or press **Alt+L**, and enter the line number.

3. Set the Run Settings.

To bring up the Run Settings dialog box click on the **Run Settings** button, or press **Alt+U**.

4. Set the Verification Settings.

To bring up the Verify Settings dialog box click on the **Verify Settings** button, or press **Alt+E**.

5. Run the Program.

To start running the program, click on the **Run Program** button, or press **Alt+R**. To cancel running the program, click on the **Cancel** button, or press **Esc**.

While a program is running, the Machine Info Window and the Message Bar keep you informed by providing information on:

- ◆ The name of the NC program.
- ◆ Which block is currently being executed.
- ◆ How many blocks are in the program.
- ◆ Which tool is being used.
- ◆ The number of passes made.
- ◆ The tool diameter.
- ◆ The spindle speed.
- ◆ Operator messages such as which block paused the program or the error that caused the program to stop.

## Verify Command

The Verify command allows you to view tool path verifications of your NC part programs. When you select Verify from the Program Menu, the Verify Program dialog box appears.

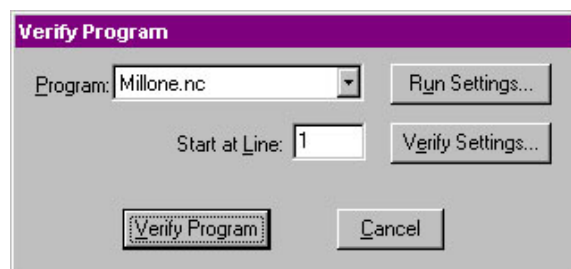

**Note:** If you are verifying a part program for the first time, you should begin the verification at line one.

This dialog box allows you to select a program to verify from a pull-down list of currently open NC part programs. Prior to verifying the part program, you may wish to alter the Run Settings, alter the Verification Settings, or select a starting block in the program. The default starting block is line one.

Begin the verification by pressing the Verify Program button. If the Verify Window is not already open, it will open automatically.

Tool path verification is displayed in the Verify Window. The workpiece and tool are displayed according to the choices you made in the Verify Settings dialog box.

Here is an example of how the Verification may appear for the part program MILLONE.NC.

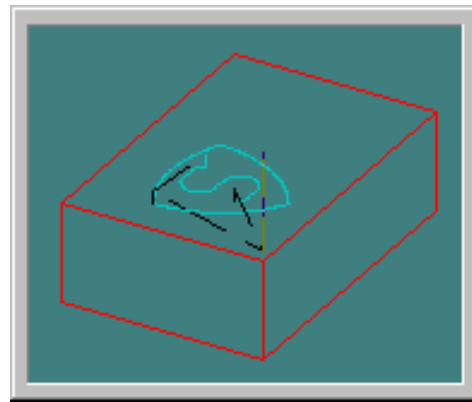

**Note:** The Calculated Distance is the total distance that the tool moves in relation to the workpiece. The calculations are made by taking into account feed rates and rapid traverse rates to determine ideal run time.

## Estimate Runtime Command

Use the Estimate Runtime command to calculate the approximate amount of time BENCHMAN requires to machine your part, and the approximate distance the machine travels while machining your part.

The Estimate Runtime command accounts for Dwell times and subprograms when calculating estimated run time, but it can not account for stops that have indefinite length of stop time. These program stops include:

- ◆ Pause (G05/M00)
- ◆ Chain (M20)
- ◆ Skip (G31)
- ◆ Wait for input high/low (G25/G26)
- ◆ Write to file (M22)
- ◆ Rerun (M47)

The Estimate Runtime command treats M47 Rewind codes as M2 End of Program codes.

This command also verifies the syntax of your NC programs while calculating the estimated run time. If an error is found, the Estimate Run Time command alerts you with a dialog box, and places the cursor near the error.

## Pause Command

Use the Pause command to pause a running NC program. Pause may also be used during tool path verification. The pause is not immediate; it takes effect after the current NC block has been executed.

To use the Pause command, select **Pause** from the Program Menu, or click the Pause button on the Standard Toolbar.

You may jog the machine and operate outputs during a Pause. If you jog the machine during a pause and don't return to where the pause started, you will be prompted with a dialog box. The software will force you to return to the resume position before continuing.

To resume running a program after a Pause, press **F5**, click the **Run** button on the Standard Toolbar or the **Go** button on the Message Bar, or press the Cycle Start button on the machine.

## Feedhold Command

The Feedhold command is very similar to the Pause command. Use it to pause a running NC program. The differences between a Pause and a Feedhold are:

- ◆ A Feedhold pauses the NC program immediately; it does not wait until the current block is executed.
- ◆ Feedhold does not work during tool path verification.
- ◆ You cannot jog the machine or operate outputs during a Feedhold.

To use the Feedhold command, select **Feedhold** from the Program menu.

To resume running a program after a Feedhold, press **F5**, click the **Run** button on the Standard Toolbar or the **Go** button on the Message Bar, or press the Cycle Start button on the machine.

## Stop Command

You can use the Stop command under the Program Menu to halt a running NC program. The machining center will immediately halt cutting.

**To use the Stop command:**

1. Select **Stop** from the Program Menu, press **Ctrl+Space**, or click the **Stop** (red) button on the Standard Toolbar. A message box appears.
2. Clear the box by clicking **OK** or pressing **Enter**. You are automatically returned to the Edit mode.

**To restart a program after a Stop is performed through the Control Program:**

1. Manually jog the tool so it is above the workpiece to avoid a tool crash.
2. Select the **Run/Continue** command to restart the NC program. The program will begin at the first line, unless otherwise specified.

**Note:** An NC program can also be stopped by pressing the Emergency Stop Button on the front panel of the Machining Center.

**Note:** Be sure to make a note of the line the NC program is on before you close the message box. If you wish to continue from your stop position, you will have to enter the line number in the Run/Continue box.

## Tools Menu

The Tools Menu commands allow you to select tools, set up and use a tool library, and configure, operate, and (if your machine is equipped with an ATC), initialize the Automatic Tool Changer .

Command:	Used to:
Setup Library	Define tools used with the machining center.
Setup Tool Wizard	Aid in establishing tool lengths for use with multiple tool programs.
Select Tool	Select a tool for use on the machining center.
Insert Tool from ...	Automatically change tools using the Automatic Tool Changer.
Configure ATC	Assign particular tools for use with the Automatic Tool Changer.
Operate ATC	Control the draw bar and individual tool stations, and monitor related inputs.
Initialize Station	
Location ...	Select a tool station for initialization to a specific reference point.

## Setup Library Command

Use the Setup Library command under the Tools Menu to assign parameters to multiple types of tools used on the machining center. When you select the Setup Library command, the Setup Tool Library dialog box appears.

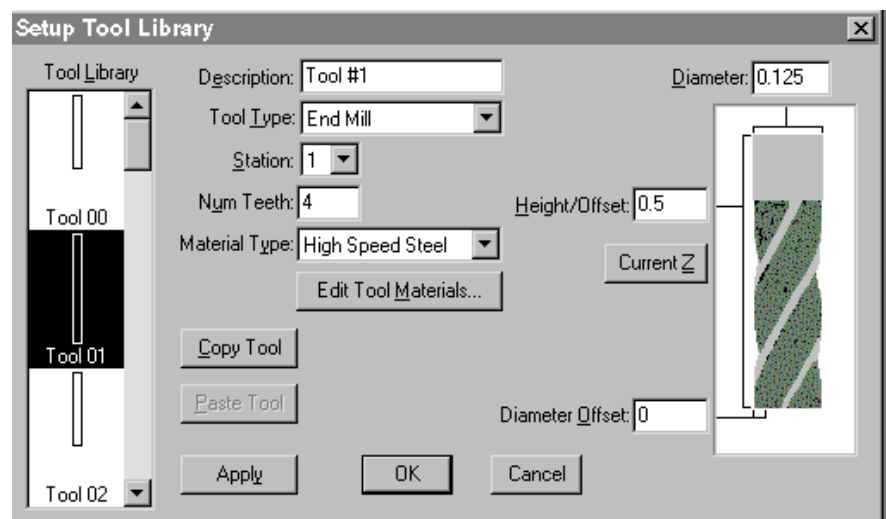



**You can create a new tool two ways:**

- ◆ Use the Copy and Paste buttons to copy an existing tool in the Tool Library box and paste it into the Tool Library box under an unassigned tool number. Assigned tool numbers are displayed with a tool icon. Unassigned tool numbers have no tool icon.
- ◆ Manually create a tool using the Setup Tool Library dialog box.

**To create a new tool:**

1. Select an unassigned tool number from the **Tool Library** list.
2. Select a tool type, such as End Mill, from the **Tool Type** drop-down menu.
3. Enter a name for the tool in the **Description** field.
4. Select a **Station** for the tool. Station numbers are provided for those systems that are equipped with an Automatic Tool Changer. If you do not have an Automatic Tool Changer, select Station #1.
5. Enter the number of teeth (**Num Teeth**) on the tool.
6. Enter the **Material Type** from which the tool should be made.
7. There is a secondary library for tool materials. You can use this library to create new materials or edit existing materials. To do this, click on the **Edit Tool Materials** button.
  - a) Enter a material **Name**.
  - b) Select a **Material Class**.
  - c) Enter a **Multiplier**. This should be set to “1” for now. This is used when integrating with CAM for calculating feed rates and spindle speeds when generating tool paths.
  - d) Click on the **Add** button.
  - e) Click on the **Delete** button to remove materials you no longer need.
  - f) Press **Enter** or click on **OK** to accept the new material. Click on **Cancel** to exit the Tool Material Type dialog box without changing the material library.
8. Enter a tool **Diameter**.
9. Enter a tool **Height/Offset** value. You may also click on the **Current Z** button to establish the current Z axis position of the tool as the Height/Offset.
10. Enter a **Diameter Offset**. The Diameter Offset is the amount of deviation from the actual cutter diameter to the programmed cutter diameter. This parameter is very important when using tool diameter cutter compensation. For example, a 0.125” diameter end mill may be specified for a job. When loading tools, the diameter of the end mill may actually measure 0.1248”. The deviation in diameter is the Diameter Offset.

11. Apply the new parameters to the selected tool number by clicking the **Apply** button.
12. Press **Enter** or click on **OK** to accept the new tool information. Click on **Cancel** to exit the Tool Library dialog box without changing the tool library.

#### To alter an existing tool:

1. Select an existing tool from the **Tool Library** list.
2. Make the desired changes to the tool parameters, then click on the **Apply** button.
3. Press **Enter** or click on **OK** to accept the new tool information. Click on **Cancel** to exit the Tool Library dialog box without changing the tool library.

## Setup Tool Wizard Command

Use the Setup Tool Wizard as an aid in establishing tool heights for use with multiple tool programs. The Wizard can be used if you are manually changing tools, or if you are using an Automatic Tool Changer.

#### To use the Setup Tool Wizard:

1. Select **Setup Tool Wizard** from the Tools Menu. This starts the Wizard.
2. Follow the Wizard's instructions carefully.

## Select Tool Command

Use the Select Tool command under the Tools Menu to select a tool for use on the machining center.

#### To select a tool:

1. Select the **Select Tool** command from the Tools Menu. The Select Tool for Use dialog box appears.
2. Select a tool from the drop-down **Tool** list. The tool parameters appear in the window to the right of the list.
3. Select an action to exit the dialog box:
  - ◆ Click the **Select Tool** button if the tool is already in the spindle.
  - ◆ Click **Insert Tool** to perform a tool change cycle. The machining center moves to its tool change position (maximum Z axis height) and you are prompted to insert a tool into the spindle. The machine will remain in this position until another motion is programmed.
  - ◆ Click **Cancel** to exit the Select Tool for Use dialog box without selecting a tool.

**Note:** Use the Select Tool Command if your machine is not equipped with an ATC, or if you have manually loaded a tool into the spindle. The machine will need to know what tool is in the spindle before running a program.

## Insert Tool From Command

Use the Insert Tool From command under the Tools Menu to automatically change tools using the Automatic Tool Changer. When you select the Insert Tool From command, a fly-out menu appears. The menu contains a list of the available tool stations, one through four. If you select Station 1, BENCHMAN automatically inserts the tool located in Station #1 on the ATC.

If your BENCHMAN is not equipped with an Automatic Tool Changer, the fly-out menu will be grayed out (the station commands are unavailable).

## Configure ATC Command

The Configure ATC command under the Tools Menu allows you to select a particular tool for use in a specific tool station on the Automatic Tool Changer. You must use the Configure ATC dialog box to tell the software which tools have been placed in each station. Each tool station has its own list of tools. The tools are assigned to a particular station by using the Station entry in the Tool Library dialog box.

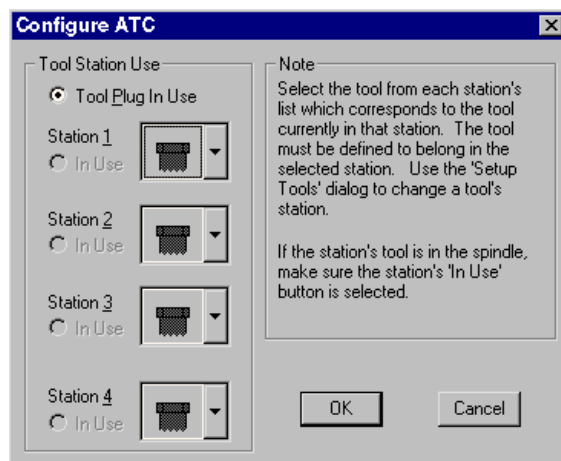

### To assign a tool to a station:

1. Select the **Setup Library** command from the Tools Menu.
2. Select the icon for the tool you wish to use from the Tool Library list.
3. Using the Station pull-down list, select the station in which you intend to place the tool.
4. Select **OK**, or select **Apply** then assign other tools.
5. Once you have exited the Tool Library dialog box, select **Configure ATC** from the Tools Menu.
6. Using the pull-down lists, select a tool for each station. Select the tool that is actually in the station. If the station is empty and that station's tool is NOT the one in the spindle, select the empty-holder icon from the list (the first one in the list).

7. If one of the tools is currently in the spindle, select the **In Use** button for that station.
8. Press **Enter** or click on **OK** to accept the new configuration, or click on **Cancel** to exit the Configure ATC dialog box without changing the configuration.

## Operate ATC Command

The Operate ATC command under the Tools Menu allows you to change the state of each tool station (raised or lowered) and the draw bar (clamped or unclamped). It also allows you to monitor the state of the inputs, including whether:

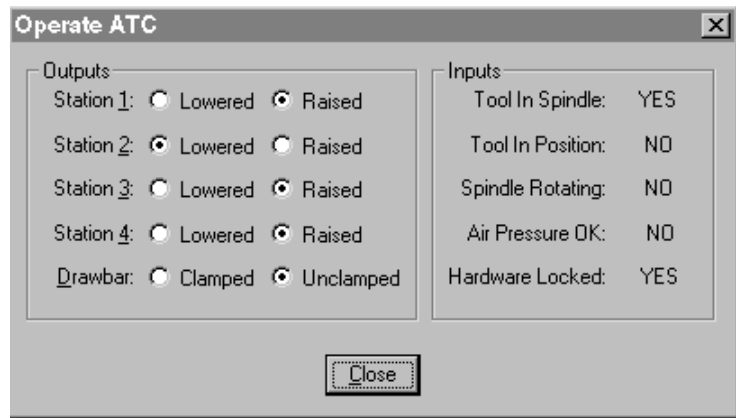

**Note:** If you have not assigned a tool to a tool station, the Control program prompts you to do so when you select a Tool Station button on the ATC Toolbar.

- ◆ There is a tool in the spindle.
- ◆ The current tool is in the correct position for a tool change.
- ◆ The spindle is currently rotating.
- ◆ There is sufficient air pressure.
- ◆ The ATC hardware is locked.

When you are finished, select the **Close** button to exit the dialog box.

## Initialize Station Location ... Command

The Initialize Station Location command under the Tools Menu allows you to initialize each tool station used with the Automatic Tool Changer. Each time you initialize a tool station, you should follow this sequence:

1. Home the machining center.
2. Insert a tool gauge plug into the draw bar.
3. Jog the cross slide to the station being set so that the plug is centered, and the tip touches the top of the tool holder in the station. The tool fork should be in the down (retracted) position.
4. Select the **Initialize Station Location** command and select the tool number from the fly-out menu.

Repeat this sequence for each tool station you are using.

## Setup Menu

The Setup Menu commands control the parameters for setting up tool positioning, jogging, running and verifying programs, coordinate systems, tool offsets, etc.

<b>Command:</b>	<b>Used to:</b>
<b>Set Position</b>	Establish the X, Y and Z position of the tool.
<b>Zero Position</b>	Set the current tool position to X0, Y0, Z0.
<b>Jog Settings</b>	Establish speed and distance parameters for jogging the tool.
<b>Run Settings</b>	Establish options for running an NC part program.
<b>Verify Settings</b>	Establish options for verifying an NC part program.
<b>Verify Type</b>	Select centerline or solid view for tool path verification.
<b>Set/Check Home</b>	Establish or check a fixed known position on the machine.
<b>Goto Position</b>	Automatically move the tool to a specific set of coordinates on the machining center.
<b>Units</b>	Select Inch or Metric units of measure.
<b>Coordinate Systems</b>	Define multiple coordinate systems or select a new coordinate system.
<b>Offsets</b>	Modify the table of offset values used for certain NC codes.
<b>Spindle</b>	Specify a spindle speed if you have not used an S code in your NC program.
<b>Backlash</b>	Define the amount of backlash in the machining center axes.
<b>Soft Limits</b>	Establish software limits for each axis within the machine coordinate system.
<b>Preferences</b>	Establish defaults for saving files and security features.

## Set Position Command

**Note:** This command sets the position of the tip of the tool to the specified values. It takes the tools defined height into account.

Use the Set Position command under the Setup Menu to set new X, Y and Z positions for the tool. This command establishes a Work Coordinate System in relationship to the Machine Coordinate System. Setting the X, Y and Z coordinates for the tool also defines the zero point of the coordinate system for absolute motion. For more information on coordinate systems, see page H-27.

This command is also available under the Position Window Pop-up Menu.

**To set a new position:**

1. Move the tool to the desired position.
2. Select **Set Position** from the Setup Menu.
3. Enter a new X position.
4. Enter a new Y position.
5. Enter a new Z position.
6. Press **Enter** or click on **OK**.

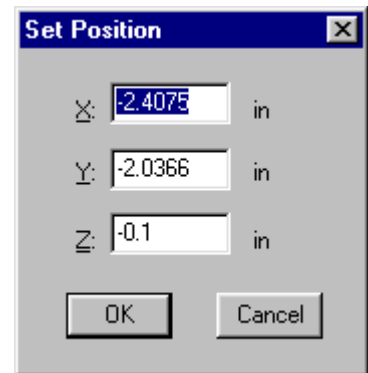

The new position is displayed in the Position Window.

## Zero Position Command

Use the Zero Position command under the Setup Menu to reset the point of origin (0,0,0) at any position on the machining center. Since the tool length and the workpiece position on the cross slide may vary from one tooling set up to another, the zero position must be initialized each time set up is changed.

This command is also available under the Position Window Pop-up Menu.

**To set the zero point:**

1. Move the tool to the point on the workpiece you intend to establish as the zero point.
2. Select **Zero Position** from the Setup Menu. The new position (0,0,0) is displayed in the Position Window.

## Jog Settings Command

Use the Jog Settings command to enter speed and distance values for the Jog Control Panel. This command is also available through the Jog Control Panel Pop-up Menu.

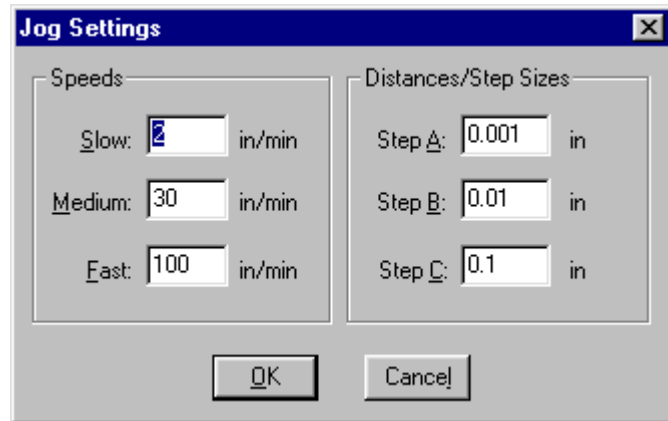

To set jog parameters:

1. Select **Jog Settings** from the Setup Menu.
2. Enter the desired jog speeds and distances.
3. Select **OK** or press **Enter**. The new values are applied to the Jog Control Panel.

### Jog Speed

The jog speed is the rate at which the tool moves along the X, Y, or Z axes. Select the speed by pressing the appropriate button. The speed can be Slow, Medium, or Fast.

**Default Values for Speed:**

- ◆ 2 ipm for Slow (52 mm/per minute)
- ◆ 30 ipm for Medium (780 mmpm)
- ◆ 100 ipm for Fast (2600 mmpm)

### Jog Distance (Steps)

Distance values determine how far the tool moves each time a key is pressed. Referred to as Steps, the distance is selected by pressing the A, B or C buttons. The distance can be set at a low value (for instance 0.005 inch) to move the tool for a precise cut, or at a higher value to position a tool.

**Default Values for Steps:**

- ◆ 0.001 inch (0.0254 mm) for Step A
- ◆ 0.01 inch (0.254mm) for Step B
- ◆ 0.1 inch (2.54mm) for Step C

## Run Settings Command

Use the Run Settings dialog box to set or clear options for running your NC program. The available options are:

- ◆ Single Step
- ◆ Optional Skip
- ◆ Optional Stop
- ◆ Enable Subprograms
- ◆ Arc Centers Incremental
- ◆ Treat Warnings as Errors
- ◆ Restore Unit Mode When Done
- ◆ Verify While Running

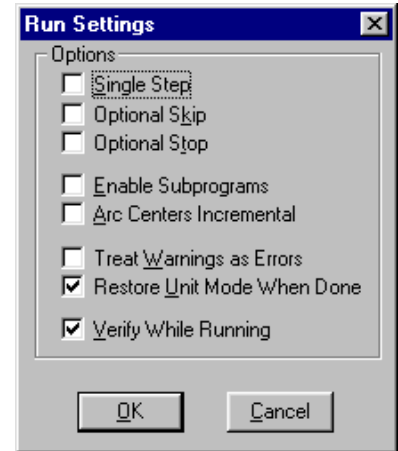

### Single Step

This option inserts a Pause after each line of the NC program. To move on to the next line in the program, you can:

- ◆ Click the **Run** button on the Standard Toolbar.
- ◆ Click the **GO** button on the Message Bar.
- ◆ Press **F5**.
- ◆ Press **Enter**.
- ◆ Select **Run/Continue** from the Program menu.
- ◆ Press the Cycle Start button.

### Optional Skip

Use this option to enable or disable the optional skip code. The optional skip code allows you to skip blocks of code as the NC program is run.

Make sure to check off the Optional Skip box in the Run Settings dialog box or activate the Optional Skip button on the Operator Panel. Then place a forward slash ( / ) in front of each line in the NC program you want to skip.

With Optional Skip off, each skip code is ignored and each block of code is executed. With Optional Skip on, each skip code is recognized and each block of code that has been tagged with a skip code is skipped.

To execute particular blocks every nth pass, place a number after the optional skip. For example: **/5G28; Home every fifth pass**



## Optional Stop

This enables or disables the optional stop code (M01). The optional stop code allows you to place an optional stop in your NC program. To activate the optional stop, select the Optional Stop box in the Run Settings dialog box, or select the Optional Stop button on the Operator Panel. Be sure you have put an M01 code on the line where you would like to pause.

With the Optional Stop option on, the M01 works like an M00 or G05. With Optional Stop off, the M01 code is ignored, the other codes on the line are executed as usual.

## Enable Subprograms

Use this option to enable or disable the use of subprograms. With this option disabled, M98 commands generate an error. Running or verifying a program with subprograms enabled takes longer to start because the software parses the entire file for subprogram information. This extra delay should only be noticeable with large programs.

## Arc Centers Incremental

Use this checkbox to specify the default mode for programming arc centers. If this box is checked, the default mode is the Fanuc mode, in which arc centers are always incremental. If this box isn't checked, the default mode is EIA-274, in which arc centers follow the general programming mode: Absolute when the mode is absolute, and incremental when the mode is incremental.

## Treat Warnings as Errors

This command is used for special applications, where you don't want any unexpected pauses in the program execution. For example, a warning is displayed and the program pauses, waiting for your input before it continues.

When this item is selected, any warning will halt the program, performing a Program Stop. When motion is stopped, all outputs are turned off.

## Restore Unit Mode When Done

If you normally work in one unit mode (inch or metric) but would like to run a program in another mode without disrupting your default settings, select this box.

Select a specific unit mode by using one of the G20/G21 or G70/G71 commands at the beginning of your NC program. Once the NC program is executed, your default unit mode will be restored.

For instance, if you normally work in Inch Mode, but have a particular program you would like to run in Metric Mode, select the **Restore Unit Mode When Done** box. Place a G21 code at the beginning of your program, then run it. When the program is finished, the default for your system will still be Inch Mode.

**Note:** The NC program itself can override the default by placing the Incremental Arc Centers (%) or Absolute Arc Centers (\$) codes in the first line of the file.

## Verify While Running

If this box is selected, the Verify window will display the program verification while the program is running. The verification does not show exactly what is happening on the machining center. There is a delay between each tool motion. You will see each tool motion on the screen, but the *verification screen will pause* until the machine finishes the motion and the next program block is read.

## Verify Settings Command

Use the Verify Settings command to open the Verify Setup dialog box. This dialog box controls the appearance of the tool path verification. You can also access this dialog box using the Verify Window Pop-up Menu.

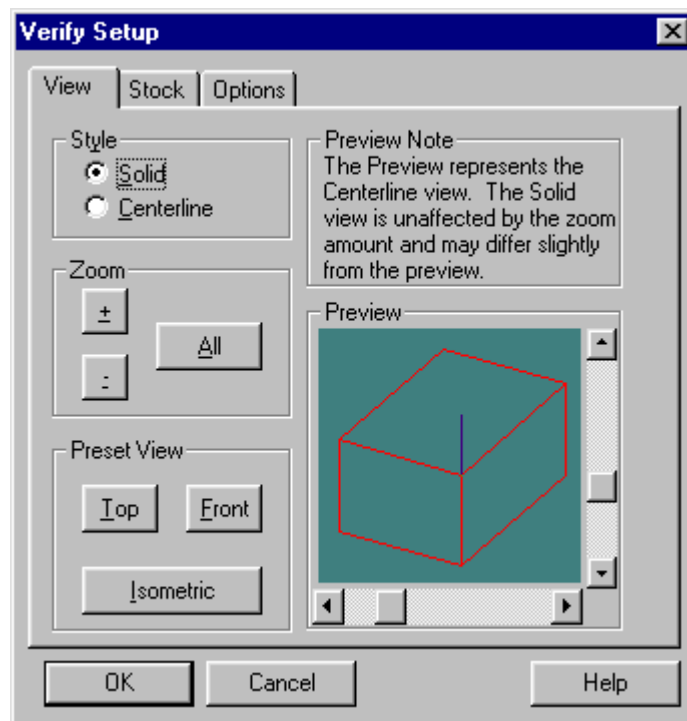

The Verify Settings dialog box is tabbed, with the settings organized into three panels: View Panel, Stock Panel and Options Panel.

## View Panel

The View panel allows you to control the view style and zoom factor. It also offers a selection of preset views.

### Style

Use these radio buttons to select between Solid and Centerline views of the stock. Solid View is a solid three-dimensional view of the workpiece and toolpath. Centerline View is a view that depicts the centerline of the toolpath. Instead of a solid model, the workpiece is shown in wireframe.

### Zoom

Use these buttons to control the size of the stock in the Verify Window. You can click on the buttons or use Alt key combinations (**Alt++**, **Alt+-**, and **Alt+A**). Each mouse click or key combination used zooms by an increment of one.

Button	Function
+	Zoom in on the stock.
-	Zoom away from the stock.
All	Fit the stock into the window.

### Preset View

Use these buttons to select a perspective, then use the Preview Window to fine-tune the angle:

Button	Function
Front	View the stock directly from the front. The stock appears as a rectangle along the X, Z axes.
Top	View the stock directly from above. The stock appears as a rectangle along the X, Y axes.
Isometric	View the stock at an angle, in three dimensions.

## Stock Panel

All stock values are interpreted according to the Units Mode in effect at the time they are set. To quickly see which Units Mode is currently in effect, check the Position window.

### Stock Dimensions

Use this area to set the dimensions of the stock used in the verification process. You will see the stock in the Preview Window change as soon as you enter a dimension.

### Origin

Use this area to adjust the verification for different workpiece setups. Most NC programs set the 0,0,0 point at the top of the front-left corner of the stock. Occasionally, however, you may want to use a different origin (the center of the stock, for example). In this case, you must enter that point to properly verify your program. The values entered should correspond to the coordinates for the front left corner of the stock relative to the 0,0,0 point for the program.

For instance, if the origin for the program is the center of a 3x2x1 piece of stock, set the origin to -1.5, -1.0.

### Initial Tool Position

You can select a tool start point using Initial Tool Position. This parameter is only used for verification, not for actually running a program. When Verifying While Running, the actual tool position is used as the initial tool position.

## Options Panel

The Verify Options control certain aspects of the solid and centerline verification display.

### Solid Options

**Auto-refresh** automatically refreshes the solid display of the workpiece during verification. The screen is updated when something changes, such as resizing the Verify Window, changing the view, or changing the stock dimensions. When auto-refresh is disabled, you will need to manually cause the verify window to update by selecting the Redraw command from the Verify Window's Pop-up Menu. This setting only affects refreshing the window when no verification is in progress.

### Centerline Options

**Auto-refresh** automatically refreshes the centerline display of the workpiece when something changes during verification.

**Show Tool** controls whether or not the tool is displayed in the Verify Window.

**Show Rapid Moves** displays the rapid moves made between the end point of one cut to the start point of another.

## The Preview Window

The Preview Window appears in each of the above groups. The Preview Window shows you approximately what the Verify Window will look like. The Preview Window always depicts the stock in Centerline view.

In addition to depicting how the Verify Window will look, you can use the preview box to change the orientation of the stock:

- ◆ Use the slider bars on the side of the Preview Window to rotate the stock along the X, Y plane and along the Z plane. There are two ways to control the sliders:
  1. Select the slider button by clicking on it with the mouse. Hold the left mouse button down while sliding the button along the bar until the stock is in the desired position.
  2. Select the slider button by tabbing to it. The button will blink to indicate it is selected. Use the arrow keys on the keyboard to move the slider button along the bar until the stock is in the desired position.

**Note:** If you re-size the window during verification, a black bar will appear at the top of the Verify window. This is the progress bar, which appears when the verify window is "catching up" with the program.

- ◆ Use the mouse to rotate the stock in all planes simultaneously. “Grab” the stock by clicking and holding it with the mouse. Move the stock with the mouse until the stock is in the desired position.

## Buttons

The **OK** button at the bottom of the dialog box applies the changes you have made and closes the dialog box.

The **Cancel** button closes the dialog box without applying any of the changes you have made.

The **Help** button brings up this Help topic.

## Verify Type Command

Verify Type allows you to choose between a solid view and a centerline view in the Verify Window. Solid View is a solid three-dimensional view of the workpiece and tool. Centerline View is a view that depicts the centerline of the tool. Instead of a solid model of the tool, the workpiece is shown in wireframe.

## Set/Check Home Command

Use the Set/Check Home command under the Setup Menu to establish or check a fixed known position on the machine. This command is also available through the Jog Control Panel Pop-Up Menu.

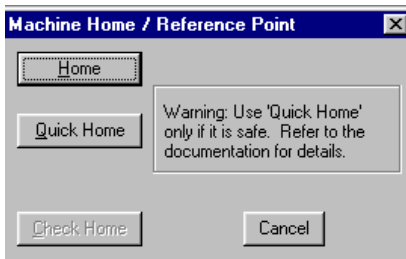

### Home

This option moves the machining center’s spindle, cross slide and saddle to the ends of travel along each axis and sets the Machine Coordinate System to X0, Y0, Z0.

### Quick Home

This option is for homing when you have lost position slightly, or when you start the machine at the beginning of the day and the machine hasn’t moved. Using this option, the Control Program assumes that it is close to being homed (that it knows approximately what the machine position is). The Control Program rapids the machine to a short distance from the limits before homing; this is much faster than feeding in at the normal rate. The Quick-Home feature is particularly useful for homing the machine after hitting a limit or after pressing the Emergency Stop while the machine is moving at a high speed.

### Check Home

This option checks the reference point, identical to using a G27 code. It compares the reported position against zero to see if any position has been lost.

## Goto Position Command

The Goto Position command opens the Goto Position dialog box. Use the Goto Position dialog box to move the tool to a particular coordinate position on the machining center.

This command is also available under the Position Window Pop-Up Menu and Jog Control Panel Pop-up Menu. You can also double click on the Position Window.

To use the Goto Position command:

1. Enter the coordinates for the new tool position.
2. Enter the feed rate at which you would like the tool to travel.
3. Click on the **Go** button. The tool moves to the new position at the defined feed rate.

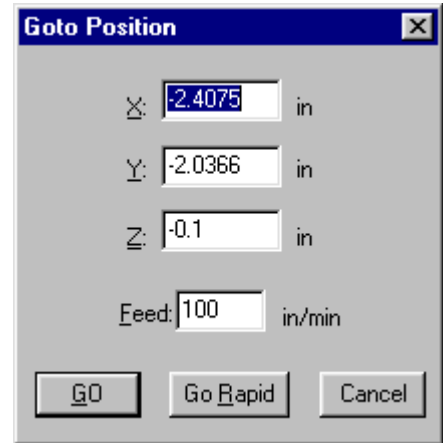

**Note:** If you would like the tool to travel at the Rapid feed rate, click on the Go Rapid button instead.

## Units Command

Use the Units command under the Setup Menu to select the unit of measure for the application. When you select the Units command, a fly-out menu appears allowing you the option of using Inch (standard) or Metric measurement.

## Coordinate Systems Command

Use the Coordinate Systems command under the Setup Menu to define multiple coordinate systems for machining more than one workpiece. This is often done for production runs of the same part. This command is also available under the Position Window Pop-up Menu. For an overview of coordinate systems, see page H-27.

To select an existing coordinate system:

1. Select **Coordinate Systems** from the Setup Menu.
2. Select an existing coordinate system from the fly-out menu. The coordinate systems available, CS1 through CS6, are equivalent to using the codes G54 through G59 in your NC program.
3. Or select the Work Coordinates command to cancel the Coordinate System offsets and return to Work Coordinates.

To define a coordinate system:

1. Select **Coordinate Systems** from the Setup Menu.
2. Select **Setup** from the fly-out menu.

## IMPORTANT NOTE:

Machine coordinates are established by Homing the system to establish a point of origin at the ends of travel on the Machining Center. Once established, these coordinates remain fixed. Each time you turn on the machining center, you should Set Home in the Setup Menu. Most machine operations will require this.

Work coordinates are different. When you use the Set Position command to set a point of origin on the workpiece, you are actually entering a position that is offset from the fixed machine position. The same thing occurs when you use a G92 code.

Work Coordinates are not fixed; they can be established anywhere on the system by using either the Set Position command or the G92 code.

Within the Work Coordinates you can set separate coordinate systems using the codes G54 through G59, or the Setup Coordinate Systems dialog box.

If you reset the Work Coordinates either with a G92 code or in the dialog box, the G54-G59 Coordinate System offsets will change accordingly.

If you Home the machine while using Coordinate systems, the offsets will not be affected.

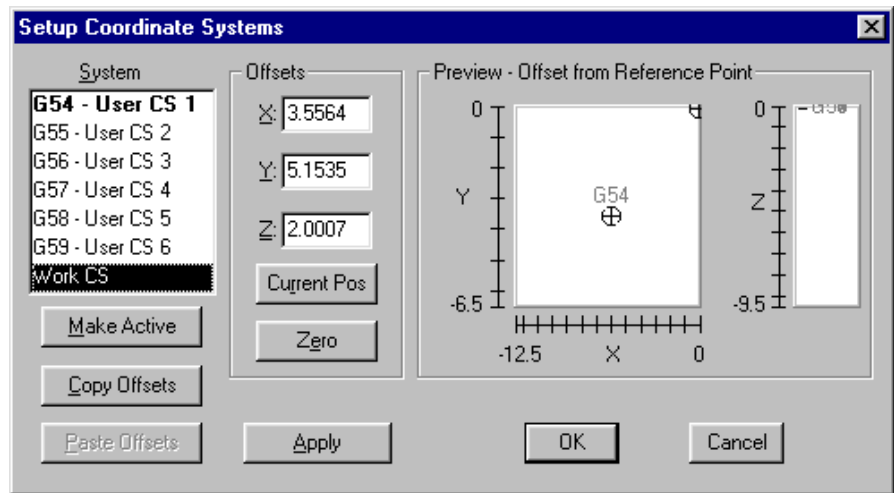

### 3. Select a coordinate system, then enter and apply the offsets.

- Select a CS from the **System** box.

The system titled "Work CS" contains the current values for the work coordinate system. This is like adding a G92 code to your NC program. You can change the default for the work coordinate system by entering new values in the Offsets boxes. These values are offset from the true origin of a coordinate system and affect all coordinate systems.

- Select the offsets for the user-coordinate system using one of the following methods:
  - ◆ Entering X, Y and Z offset values in the **Offsets** boxes.
  - ◆ Clicking the **Current Pos** button to establish offset values based on the current tool position.
  - ◆ Selecting a Marker in the **Preview Area** for the coordinate system and dragging it to the desired position.
  - ◆ Copying offsets from one CS to another using the **Copy Offsets** and **Paste Offsets** buttons.
- Make the currently selected CS the active CS by selecting the **Make Active** button.
- Apply the coordinates or exit the dialog box:
  - ◆ The **OK** button applies the changes you have made and closes the dialog box.
  - ◆ The **Cancel** button closes the dialog box without applying any of the changes you have made since clicking the Apply button.
  - ◆ The **Apply** button applies the changes you have made and leaves the dialog box open in case you wish to make more changes (you can still cancel changes once they have been applied by selecting the Cancel button).

## Offsets Command

Use the Offsets command under the Setup Menu to modify the table of Offset Values used for certain NC codes. These offsets are typically used to compensate for variations in the cutting tools being used. The offset values are used for tool length offset, cutter compensation, and tool offset adjustment NC codes.

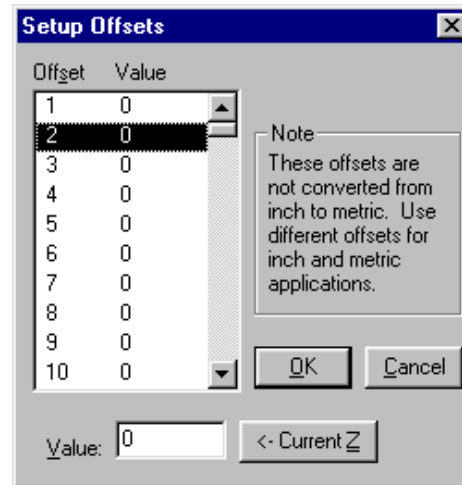

### To enter a compensation offset:

1. Select **Offsets** from the Setup Menu.
2. Click on an Offset Number (the numbers 1 through 199 are available). This number only acts as a designation (a name) for the offset.
3. Enter an Offset Value in the **Value** box, or select the **Current Z** button to use the current Z position (this is useful for defining tool heights if you are using G43 or G44 to specify tool heights).
4. Press **Enter** or click on **OK**. The Offset Value has been associated with the Offset Number. The next time you open the Offsets Table, you will see the new offset.

### The Offset Table

The Offset Table stores up to 200 values which are used in several operations including tool offset adjustment, cutter compensation, and tool length compensation to ensure uniform application of an offset value. The numbers are stored as unit-less values; their interpretation depends on the Units currently in effect.

Set the values in the Offset Table using the Offsets command under the Setup Menu. The Offsets are stored in the **Bench4k.ini** file when running with a machine, and in TESTCTL.INI when running in simulation mode.



## Spindle Command

Use the Spindle command under the Setup Menu to specify a spindle speed if you have not used an S code in your NC program.

To specify a spindle speed:

1. Select the **Spindle** command from the Setup Menu. The Spindle Setup dialog box appears.
2. Select a spindle speed by entering a value in the RPM box, or by using the slider and arrow buttons.

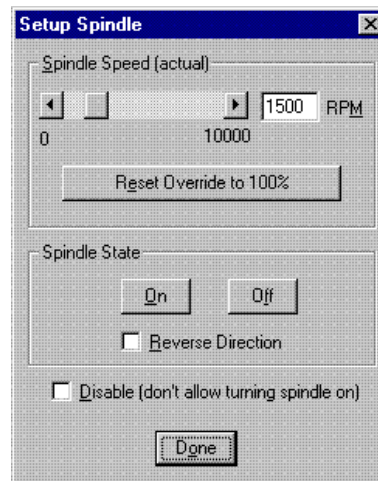

Also in this dialog box:

- ◆ Reset the spindle override value to 100% by clicking on the **Reset Override to 100%** button.
- ◆ Change the On/Off state of the spindle using the **On** and **Off** buttons in the Spindle State area.
- ◆ Reverse spindle direction by selecting the **Reverse Direction** box.
- ◆ Disable spindle operation by selecting the **Disable** option. This is useful if you have a device mounted in the spindle that should not be rotated, such as a wired probe.
- ◆ Select **Done** to close the dialog box.

## Backlash Command

Use the Backlash command under the Setup Menu to define the amount of distance that is lost when reversing direction. The system default is set at a backlash value of 0.0 on all three axes, with a feed rate of 10 ipm.

To establish new backlash parameters:

1. Select **Backlash** from the Setup Menu.
2. Enter the desired backlash distances and feed rate.
3. Press **Enter** or click on **OK** to accept the new backlash parameters, or click on **Cancel** to exit the Setup Backlash dialog box without setting new backlash parameters.

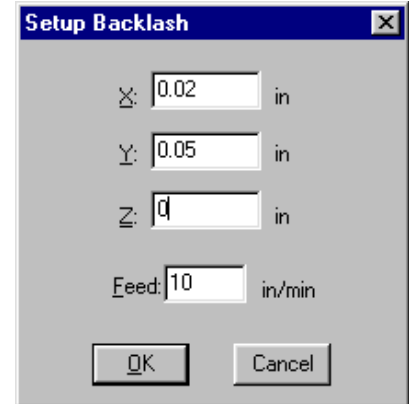

**Note:** You should not specify too slow of a backlash feed rate or you will notice delays each time an axis with backlash changes direction.

## Soft Limits Command

Use the Soft Limits command under the Setup Menu to establish software limits for each axis. The limits are different than the fixed hardware limits on the machining center. Soft limits can confine the tool travel to an area smaller than the normal maximum travel.

The machining center shuts down if it trips a soft limit, just as it does when it trips one of the limit switches. This is helpful when working with devices such as robots, or when you have installed fixtures within the normal work area that you don't want the tool to hit.

To establish software limits on the machining center:

1. Select **Soft Limits** from the Setup Menu.
2. Enter the coordinates, relative to the Home position, that define the software perimeter you wish to establish.
3. Click on the **Enable Soft Limits** option to enable soft limits. Use this option to turn soft limits on or off as you need to use them.
4. Press **Enter** or click on **OK** to accept the new soft limit parameters, or click on **Cancel** to exit the Setup Soft Limits dialog box without setting new soft limit parameters.

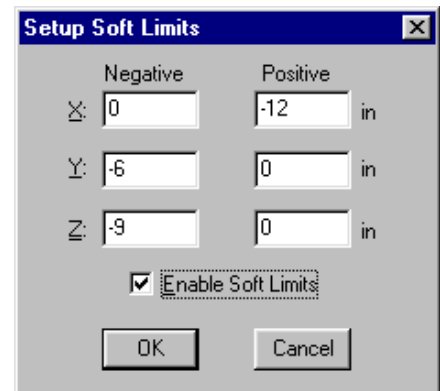

---

### IMPORTANT!

---

Soft limits are defined in relation to the machine coordinates; therefore, you must home the Machining Center before using soft limits. Soft limits are not enforced if the Machining Center has not been homed.

**Note:** You must be within the Soft Limit range in order to Enable the Soft Limits. If you are outside of the Soft Limit range and Soft Limits are enabled when you close the dialog box, you will be instructed to jog the machine to within the Soft Limits. After you do so, you can open the Soft Limits dialog box and enable them.

## Preferences Command

Use the Preferences command under the Setup Menu to establish defaults for saving files and setting security features.

To alter the system preferences:

1. Select the **Preferences** command from the Setup Menu.
2. Select the Control, Editor, or Security preferences tab.

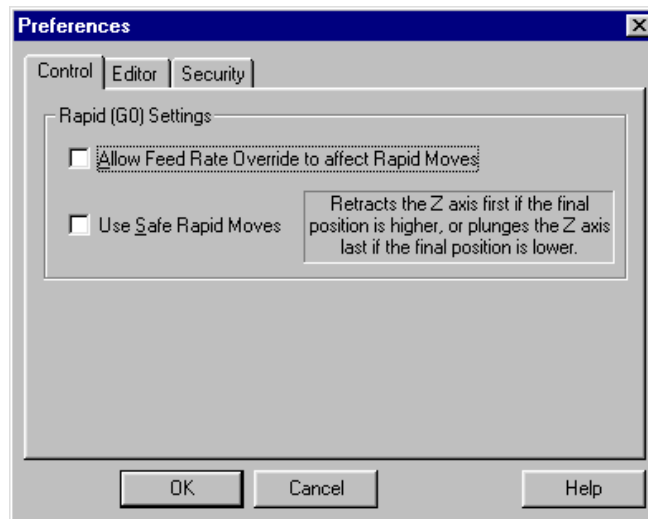

### Control Preferences

The Control Preferences allow you to control some of the machine motions. If you want the feed rate override setting to affect the speed of rapid moves, select the checkbox on this panel. Forcing the machine to use Safe Rapid Moves means moving the spindle away from the workpiece before executing any rapid moves.

### Editor Preferences

The Editor Preferences allow you to automatically save your NC program files at regular intervals, and establish a default directory in which to store your files. When you select the Editor tab in the Preferences dialog box, the Editor panel appears.

The **Hilite Comments** box will highlight comments in the NC program in a different color.

The **Quick Run/Verify by Default** box suppresses the messages and dialog boxes that appear asking for the file name and starting line when you run a program.

To select AutoSave features:

- ◆ Select **Save when idle** and enter a value in the **Every:\_\_\_ minutes** box to save your NC programs automatically at the specified time increment.

- ◆ Select **Save Before Running** to save changes to your NC program prior to running it for the first time with the changes.
- ◆ Select **Prompt Before AutoSaving** if you wish to be prompted by the Control Program before it automatically saves the NC program at the specified time increment.

**To select File Default features:**

- ◆ Enter an **Extension** for your NC part program files. The default is “NC.”
- ◆ Select **Lock Files When Opened** to have your NC programs locked by default. Deselect this feature to have your NC programs unlocked by default.
- ◆ Select the **Set** button to specify a target directory in which to save your NC program files. The default directory appears in the Directory box.

**To exit the Preferences dialog box:**

Press Enter or click on **OK** to accept the new preference settings, or click on **Cancel** to exit the Preferences dialog box without setting new Editor or Security Preferences.

**To access Help for this panel:**

Select the Help button to access the Help files for this panel.

## Security Preferences

The Security Preferences allow you to control which features others may use. When you select the Security tab in the Preferences dialog box, the Security panel appears.

The Security Preferences panel offers two modes, User and Administrator. Administrator Mode allows a supervisor, such as a teacher in a classroom, to turn commands on or off using the Allowed Commands list. User Mode does not have access to this feature.

**To secure the software using Administrator Mode:**

1. Set the **Default Mode** to **User**. (Note that this will not change the current mode.)
2. Use the **Change Password** button to create a password. The default password is blank (no password).
3. Select the **Allowed Commands**. Double-click on the listed commands to enable or disable them. If the commands are enabled, they are marked with an X. A description of each selected command is displayed on the right side of the panel.
4. Use the **Change Mode** button to change to User Mode.
5. Select **OK** or press **Enter** to exit the Preferences dialog box.

The software is now running in User Mode. The next time you open the Preferences dialog box, the Security preference panel is displayed in User Mode. In this mode it is not possible to turn commands on or off.

**To return to Administrator Mode:**

1. Use the **Change Mode** button to toggle the Mode from User to Administrator. A dialog box appears, prompting you to enter your password.
2. Enter your password and press **Enter** or click on **OK**.

**To change your password:**

1. Click on the **Change Password** button.
2. Enter your current password.
3. Enter the new password.
4. Enter the new password again to verify that it is correct.

**To exit the Preferences dialog box:**

Press **Enter** or click on **OK** to accept the new preference settings, or click on **Cancel** to exit the Preferences dialog box without setting new Editor or Security Preferences.

**To access Help for this panel:**

Select the Help button to access the Help files for this panel.

---

## Window Menu

The Window Menu commands allow you to manipulate the arrangement of the Program Edit Windows.

Command:	Used to:
<b>Cascade</b>	Layer the open edit windows.
<b>Tile</b>	Tile the open edit windows.
<b>Arrange Icons</b>	Arrange any minimized edit windows along the bottom of the edit area.
<b>Window List</b>	Display and select from the currently open NC programs by their file names.

## Cascade Command

Similar to the standard Windows/Cascade command. Places the open Program Edit Windows in a layered format, cascading down to the right with the currently selected window on top.

## Tile Command

Similar to the standard Windows/Tile command. Places the open Program Edit Windows in a tiled format, filling the Edit Area from top to bottom.

## Arrange Icons Command

When you minimize a Program Edit Window, it becomes a small icon. The Arrange command under the Window Menu arranges these icons along the bottom of the edit area.

## Window List Command

Lists the currently open Program Edit Windows. The currently selected window is designated with a check mark. You may select any window by clicking on the window itself, or by selecting the window name from this list.

---

## Help Menu

The Help Menu commands allow you to navigate through the Help files, to save or restore parameters set throughout the current session, and provides handy tips and other information about the Control Program.

Command:	Used to:
Help	Display Help for the current task or command.
Index	List Help topics.
Using Help	Display instructions about how to use Help.
Save Settings	Save the current machine and application settings.
Restore Settings	Reset machine and application settings from defaults.
Tip of the Day	Display a Tip of the Day.
About Benchman	Display program information, version number and copyrights.

Note: When you reset machine defaults using the Restore Settings command, all ATC initialization information is lost.

## Help Command

Use the Help command to access the Help contents. You can also press the F1 key to get information about the currently highlighted command on a drop-down or pop-up menu.

## Index Command

Use the Help Index command to access an index of available Help topics.

## Using Help Command

Use the Using Help command to obtain information on using the Help utility.

## Save Settings Command

The Save Settings command allows you to retain current library, security, screen and control settings as defaults.

- ◆ Click on a particular setting(s) to tag it, then click on the **Save** button to save the selected items and exit the dialog box.
- ◆ Click on the **Save All** button to save all settings without having to select each one.
- ◆ Click on the **Cancel** button to exit the Save Defaults dialog box without changing the existing defaults.

## Restore Settings Command

The Restore Settings command allows you to restore all or some of the current settings to the defaults you set using the Save Settings command (User Defaults) or to the factory set defaults.

- ◆ Click on a particular setting(s) to tag it, then click on a Restore From option. Click the **Restore** button to restore the selected items and exit the dialog box.
- ◆ Click on the **Restore All** button to restore all settings without having to select each one.
- ◆ Click on the **Cancel** button to exit the Restore Defaults dialog box without changing the existing defaults.

## Tip of the Day Command

This command brings up information about the operation of the machining center, tips & tricks for using the Control Program, and NC programming ideas.

## About BENCHMAN ... Command

This command brings up the BENCHMAN information box. Included is information on the Control Program version number, the release date, and copyright information.

The **Details** box allows you to see what options have been installed, and the software and firmware versions.

---

## Selecting Commands

There are a few different ways to select commands in the Control Program. Use the method that is most convenient for you.

---

### Select a Command Using Pop-Up Menus

Clicking the right mouse button on certain windows or panels brings up a pop-up menu. Each pop-up menu is context-sensitive. Commands which cannot be performed at that time are grayed out.

**To select a pop-up menu command:**

1. Position the cursor on the window or panel.
2. Click the right mouse button. The context-sensitive menu appears.
3. Select a command by moving the pointer over it and clicking the left mouse button.

**The following windows have pop-up menus:**

- ◆ Program Edit Window
- ◆ Position Window
- ◆ Verify Window
- ◆ Jog Control Panel

The Machine Info Window and Operator Panel only provide the Dockable and Hide commands on their Pop-up menus.

### Program Edit Window Pop-up Menu

The Program Edit Window Pop-Up Menu contains different combinations of these commands, depending on whether the file is locked, is being run or verified, and if text is selected.

#### Cut Command

Cut is the same as selecting the Cut command from the Edit Menu.

#### Copy Command

Copy is the same as selecting the Copy command from the Edit Menu.

#### Paste Command

Paste is the same as selecting the Paste command from the Edit Menu.





## Clear Command

Cut is the same as selecting the Cut command from the Edit Menu.

## Evaluate Selection

This command evaluates the selected text (expression) and replaces it with the result (e.g. selecting  $3/4$  and evaluating it replaces  $3/4$  with  $.75$ ). You can use parentheses, normal operations (+, -, \*, /), modulus (%), power (^), trig functions (cos, sin, tan, acos, atan, asin) and SQRT.

To use the Evaluate Selection command, the program must be unlocked, and a single line selected.

## Goto Line Command

Goto Line is the same as selecting the Goto Line command from the Edit Menu.

## Renumber Command

The Renumber command is the same as selecting Renumber from the Edit Menu. A dialog box appears that allows you to alter the N codes in the NC program.

## Save Command

Saves the current program.

## QuickRun Command

The QuickRun command is a shortcut that runs the currently selected NC part program. When you click on this command, the program behaves as though you had selected the Run/Continue Command from the Program Menu with the following exceptions:

- ◆ You do not have the option of selecting a starting line.
- ◆ You do not have the option of changing any settings.

## QuickVerify Command

The QuickVerify command is a shortcut that verifies the currently selected NC part program. When you click on this command, the program behaves as though you had selected the Verify Command from the Program Menu with the following exceptions:

- ◆ You do not have the option of selecting a starting line.
- ◆ You do not have the option of changing any settings.

## Estimate Runtime

This command performs the same function as the Estimate Runtime command under the Program Menu.

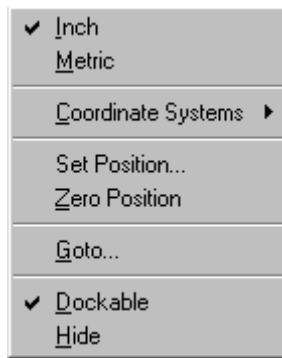

## Position Window Pop-up Menu

The Position Window Pop-Up Menu contains these commands:

### Inch Command

Automatically switches the units of measure to inches.

### Metric Command

Automatically switches the units of measure for the application to metric units.

### Coordinate Systems Command

Produces a fly-out menu that allows you to set up and select coordinate systems.

### Set Position Command

Opens the Set Position dialog box.

### Zero Position Command

Sets the current tool position to zero on all axes.

### Goto Command

Opens the Goto Position dialog box.

### Dockable Command

The Dockable command toggles the window between being a dockable window and being undockable. See *Docking and Floating Windows* for more information. This command is available on all pop-up menus for the windows and panels available under the View Menu.

### Hide Command

The Hide command closes the window. To open the window again, select it from the View Menu. This command is available on all pop-up menus for the windows and panels available under the View Menu.

## Verify Window Pop-up Menu

The Verify Window Pop-Up Menu contains these commands:

### Solid Command

Switches the verification to a solid view.

### Centerline Command

Switches the verification to a centerline view.

### Setup...

Opens the Verify Setup dialog box.

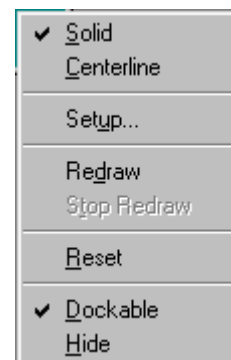

## Redraw Command

This command repeats the most recent tool path verification simulation.

## Stop Redraw Command

This command will interrupt a redraw currently in progress.

## Reset Command

This command resets the Verify Window; it clears the tool path lines and resets the tool to the starting position.

## Dockable Command

The Dockable command toggles the window between being a dockable window and being undockable. See Docking and Floating Windows for more information. This command is available on all pop-up menus for the windows and panels available under the View Menu.

## Hide Command

The Hide command closes the window. To open the window again, select it from the View Menu. This command is available on all pop-up menus for the windows and panels available under the View Menu.

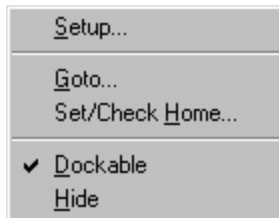

## Jog Control Panel Pop-up Menu

The Jog Control Panel Pop-Up Menu contains these commands:

### Setup Command

This command opens the Jog Settings dialog box.

### Goto Command

This command opens the Goto Position dialog box.

### Set/Check Home Command

This command opens Machine Home/Reference Point dialog box.

### Dockable Command

The Dockable command toggles the window between being a dockable window and being undockable. See Docking and Floating Windows for more information. This command is available on all pop-up menus for the windows and panels available under the View Menu.

### Hide Command

The Hide command closes the window. To open the window again, select it from the View Menu. This command is available on all pop-up menus for the windows and panels available under the View Menu.

## Select a Command Using Hot Keys

Some menu commands have one or more key designations listed next to them on the menus; these are the *hot keys* for that command. Pressing the hot key(s) selects the corresponding command.

### To select a command using hot keys:

Press the hot key for the desired command. For example, press **Ctrl+S** to save your file. Here's a list of the available hot keys:

<b>Key(s):</b>	<b>Menu/Command:</b>
<b>Ctrl+C</b>	Edit Menu/Copy
<b>Ctrl+F</b>	Edit Menu/Find
<b>Ctrl+G</b>	Edit Menu/Goto Line
<b>Ctrl+H</b>	Setup Menu/Set/Check Home
<b>Ctrl+L</b>	Edit Menu/Lock
<b>Ctrl+N</b>	File Menu/New
<b>Ctrl+O</b>	File Menu/Open
<b>Ctrl+P</b>	File Menu/Print
<b>Ctrl+R</b>	Setup Menu/Run Settings
<b>Ctrl+S</b>	File Menu/Save
<b>Ctrl+Space</b>	Program Menu/Stop
<b>Ctrl+T</b>	Tools Menu/Setup Library
<b>Ctrl+V</b>	Edit Menu/Paste
<b>Ctrl+X</b>	Edit Menu/Cut
<b>Ctrl+Y</b>	Edit Menu/Redo
<b>Ctrl+Z</b>	Edit Menu/Undo
<b>Ctrl+Shift+Z</b>	Setup Menu/Zero Position
<b>Ctrl+Shift+E</b>	Evaluate Selection
<b>F1</b>	Help Menu/Help
<b>F2</b>	Edit Menu/Delete Line
<b>F5</b>	Program Menu/Run/Continue
<b>F6</b>	Program Menu/Verify
<b>F8</b>	Setup Menu/Goto Position
<b>Ctrl+KeyPad+</b>	Increase Feed rate Override

<b>Ctrl+KeyPad-</b>	Decrease Feed rate Override
<b>Ctrl+Backspace</b>	Edit Menu/Undo
<b>Shift+Delete</b>	Edit Menu/Cut
<b>Shift+F1</b>	Context Help
<b>F4</b>	Activate Jog Control
<b>Ctrl+F5</b>	QuickRun
<b>Ctrl+F6</b>	QuickVerify
<b>Ctrl+TAB</b>	Next Edit Window
<b>Ctrl+Insert</b>	Edit Menu/Copy
<b>Shift+Insert</b>	Edit Menu/Paste
<b>Pause</b>	Pause

---

## Select a Command Using Toolbars

The Toolbars contain buttons that correspond to frequently used menu commands. Clicking a button on a toolbar is equivalent to selecting the same command from a menu, and is usually quicker. The BENCHMAN 4000 Control Program provides Standard, ATC, Input, and Output toolbars. Use the commands under the View Menu to control whether each toolbar is displayed or hidden.

---

## Positioning Screen Components

The Control Program interface is easily configured and optimized by opening, closing, resizing, and repositioning the screen components.

---

### Positioning Toolbars

#### Docking Area:

The gray portion of the screen where toolbars, windows and information areas are placed as stationary objects.

You can reposition any of the toolbars (Standard, Inputs, Outputs or ATC Control) simply by dragging them off their docking areas. Once away from the docking area, the toolbar becomes a floating window, which can be moved and closed like any other window. To move the toolbar, click on the toolbar background (the area around the buttons) and drag.

---

### Positioning Windows and Panels

The windows and panels (Position Window, Machine Info Window, Verify Window, Jog Control Panel, and Operator Panel) are initially docked on the docking area on the right side of the screen. If these items are moved away from the docking area, they become floating windows or panels until they are moved back to the docking area.

The Verify window is initially not dockable.

**To move a window or panel (create a floating window):**

1. Press the Ctrl key.
2. Click on the information area with the left mouse button.
3. Hold and drag the area off the docking area.
4. Release the Ctrl key.
5. When the floating window is over its new location, release the mouse button.  
You can move and close the window as you would any other window.

**To return a floating window to its docking area (the window must be dockable):**

1. Click on the title bar of the floating window.
2. Drag the area back to the docking area.
3. Release the mouse button.

For more information about Dockable and Undockable windows, see page E-62.

---

## Positioning Program Edit Windows

Program Edit Windows can be moved, resized or closed just like any other window. The only restriction is that the Edit Windows can not be moved out of the edit area. For instance, you can not move an Edit Window to a docking area.

---

## Saving the Window Positions

After arranging the application's windows on the screen, you can save their positions. Use the Save Settings command on the Help menu to save the window positions (and any other selected items). To restore your saved window positions, or to restore the default window positions (the factory preset positions), use the Restore Settings command on the Help menu.

The Control Program automatically stores the current window positions when you exit the software, and automatically restores them the next time you run it.

---

## Docking and Floating Windows and Toolbars

Windows and Toolbars can behave in two ways; they can be placed in a stationary state, docked, or they can be in a free-floating state, and moveable.

### Docked Screen Components

A docked screen component is fixed in place, unlike a floating component which can be placed anywhere on the screen. When a screen component is docked, the window frame and title disappear.

### Floating Screen Components

A floating screen component can be moved to any position on the Control Program screen, unlike a docked screen component, which is fixed in place. When a screen component is floating it has a window frame and title.

#### To select the Docking/Floating state of a toolbar:

- ◆ Click on the background area of the toolbar and drag it away to float it.
- ◆ Click on the background, or the title bar of the toolbar and drag it to the docking area to dock it.

#### To select the Docking/Floating state of a window:

1. Position the mouse pointer over the window you would like to dock/float.
2. Click the right mouse button.
3. Select Dockable from the drop-down menu.

When the Dockable command is checked, the window can be dragged to a docking area and docked. It can also be kept floating by moving it away from the docking areas and keeping the Ctrl key pressed. Dockable windows can **not** be resized.

When the Dockable command is not checked, the window will float and can not be docked. Floating windows can be resized.



**Note:** There are two Offset Tables, one for Simulate Mode, and one for Normal Mode. If your off-line NC program development includes using values from the offset table, you must ensure that they are present in the Normal Mode offset table and in the same positions as in the Simulation Mode offset table.

---

## Using the Offset Table

The Offset Table stores 200 values which are used in several operations including tool offset adjustment, cutter compensation, and tool length compensation to ensure uniform application of an offset value. The numbers are stored as unit-less values; their interpretation depends on the Unit mode currently in effect. Offset zero is always 0.0 and cannot be modified. Using Offset zero for most compensations cancels that compensation.

Set the values in the Offset Table using the Offsets command under the Setup Menu. The Offsets are stored separately for the machine, and for Simulation Mode.

---

## Working in Simulation Mode

Simulation mode is provided to allow the Control Program to be used when your computer is not connected to a VMC-4000 Machining Center. This is primarily to support the off-line development of NC programs.

NC program verification and running is supported in Simulation Mode. Programs will run in approximately the same amount of time that they would if a machine were attached (excluding stops that have indefinite length of stop time, see Estimate Runtime).

The principal difference between Simulation Mode and Normal Mode is, since no machine is available to send and receive data, there are no Inputs and Outputs. The Inputs and Outputs buttons on the toolbars have no affect. If your program contains commands to wait for certain input values that are not the default, the events will never occur. If the values are the default, the wait will occur immediately.

## The Setup Program

The Setup Program allows you to select a number of program and hardware defaults, as well as configure the options installed on the machine. To access the Setup Program, you must exit the Control Program. Then select the Start Menu> Programs> BENCHMAN> Setup. The program will start and you will see the Welcome screen. You may choose from the file tabs to view the defaults for each category.

The Setup Program provides defaults under the following categories:

- ◆ Welcome
- ◆ General
- ◆ Options
- ◆ Interface Card

## Welcome Panel

This panel provides one option, **Units Default**. This option sets the default unit of measure (Inch or Metric) for the Control Program and the Setup Program. When running the Control Software, you can change the default using the Units command under the Setup Menu.



## General Panel

This panel allows to you alter several software defaults.

- ◆ **Run Offline** starts the Control Program in Simulate Mode without checking for a machine connection.
- ◆ **Decimal Places for Inch Values** controls the display of values in dialog boxes. When in Metric mode, the software displays 1 less than the specified number of decimal places.
- ◆ **Tool Shaft Height** controls the tool shaft length in the Preview Window (in the Verify Settings dialog box) and the Verify Window. The control software uses this value to insure that the tool with the smallest length offset is verified with a length at least as large as this value.

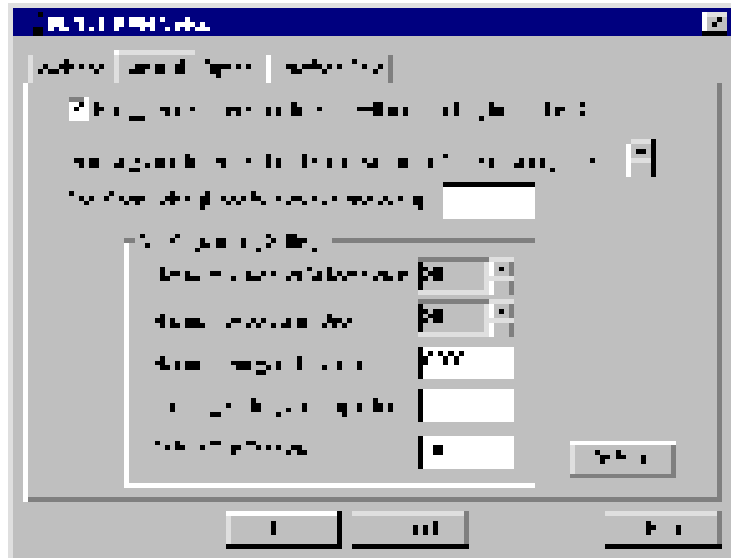

- ◆ **NC Programming Settings** controls several programming options:
  - The maximum number of subprograms.
  - The maximum depth of subprograms; the number of nested subprograms.
  - The maximum arc radii deviation; the allowable difference between the two radii,  $r_1$  and  $r_2$ , of an arc before being considered an error.
  - The default L-factor; the angle at which a line segment approximates a portion of an arc.
  - The default feed rate; the initial feed rate when running or verifying an NC program; used until a feed rate is specified in the NC program.

## Options Panel

The Options Panel allows you to match your software settings to the hardware configuration of your machine.

In the Installed Options list, select the options you want to enable or disable by checking/unchecking the box next to the option. If there are more settings for a particular option, they will be listed to the right.

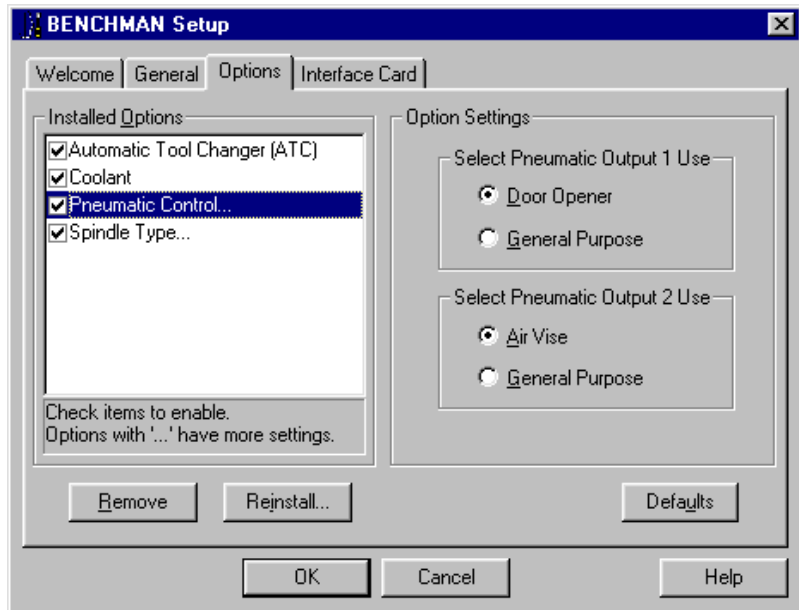

If the option you want to install is not shown, select the Reinstall button at the bottom of the panel. This displays a list of the available options. Select the desired option by placing a check in the box and choosing reinstall.

You can choose to remove or reinstall options by selecting the buttons at the bottom of the window, or restore the default settings for that option.

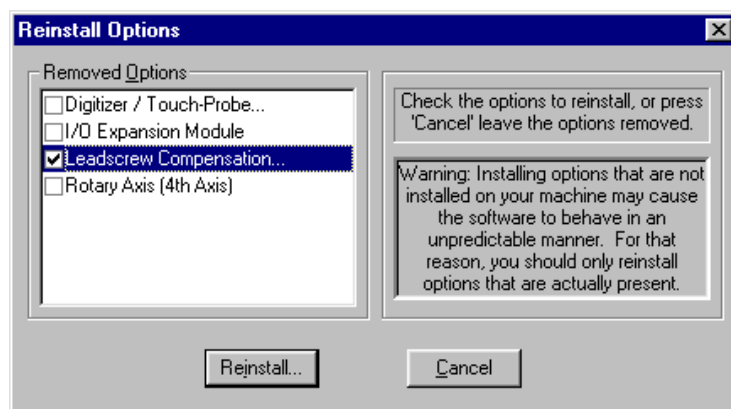

## Interface Card Panel

This panel allows you to change the **Interface Card Address**. Once you have installed the Interface Card and software, and performed the initial setup, this address should not change. However, if the Control Program does not recognize the motion control card, you probably have an address conflict and need to reset this address. For complete instructions for installing the interface card and setting the interrupt address, see Section A: Installation.

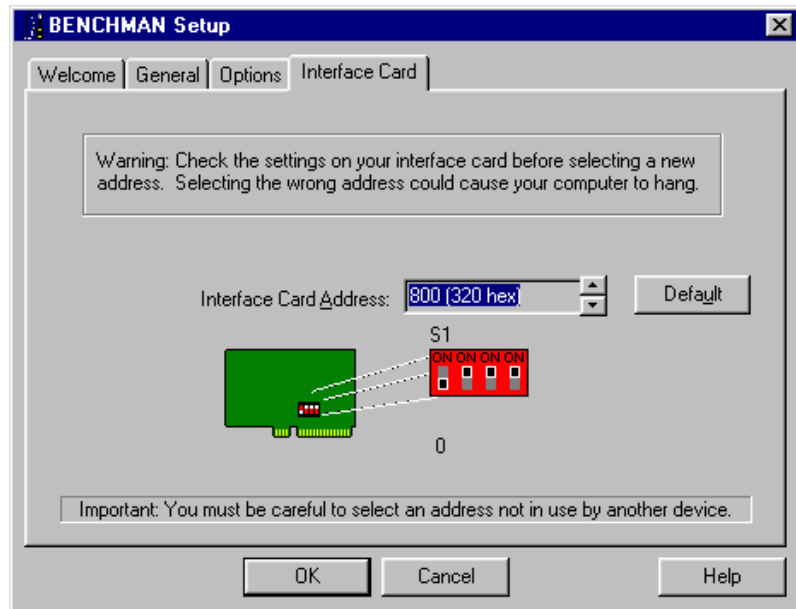



# Basic CNC Programming

**The Elements of an NC Part Program**

**Categories of NC Code**

**General Programming Suggestions**

## The Elements of an NC Part Program

Part programs generally incorporate two types of instructions: those which define the tool path (such as X, Y and Z axis coordinates), and those which specify machine operations (such as turning the spindle on or off). Each instruction is coded in a form the computer can understand.

An NC program is composed of *blocks* (lines) of code. The maximum number of blocks per program is limited by the memory (RAM) on your computer. You can, if necessary, chain programs together to form very large part programs.

Each block contains a string of *words*. An NC word is a code made up of an alphabetic character (called an *address character*) and a number (called a *parameter*). There are many categories of address characters used in NC part programs for the machining center (see Categories of NC Code).

Each block of NC code specifies the movement of the cutting tool on the machining center and a variety of conditions that support it. For example, a block of NC code might read:

```
N0G90G01X.5Y1.5Z0F1
```

If the machine is currently set for inch units, the individual words in this block translate as:

- N0** This is the block sequence number for the program. Block 0 is the first block in the program.
- G90** This indicates absolute coordinates are used to define tool position.
- G01** This specifies linear interpolation.
- X.5** This specifies the X axis destination position as 0.5".
- Y1.5** This specifies the Y axis destination position as 1.5".
- Z0** This specifies the Z axis destination position as 0". The cutting tool will move to the absolute coordinate position (0.5,1.5,0).
- F1** This specifies a feed rate of 1 inch per minute, the speed at which the tool will advance to the specified coordinate points.



## Categories of NC Code

There are many categories of NC code used for programming. The following is a list of the NC codes (designated by the address character) supported by the BENCHMAN 4000.

<b>Code:</b>	<b>Function:</b>
%	Incremental Arc Centers (Fanuc).
\$	Absolute Arc Centers (LMC).
\	Skip.
/	Optional skip.
D	Compensation offset value.
F	Feed rate in inches per minute; with G04, the number of seconds to dwell.
G	Preparatory codes.
H	Input selection number; Tool length offset.
I	Arc center, X axis dimension (circular interpolation).
J	Arc center, Y axis dimension (circular interpolation).
K	Arc center, Z axis dimension (circular interpolation).
L	Loop counter; Program cycle (repeat) counter for blocks and subprograms; Specify homing tolerance.
M	Miscellaneous codes.
N	Block number (user reference only).
O	Subprogram starting block number.
P	Subprogram reference number (with M98); Uniform scale multiplier (with G51).
Q	Peck depth for pecking canned cycle.
R	Arc radius for circular interpolation (with G02 or G03); Starting reference point for peck drilling (with canned cycle codes).
S	Spindle speed.
T	Tool specification.
U	Incremental X motion dimension for absolute dimensioning.
V	Incremental Y motion dimension for absolute dimensioning.
W	Incremental Z motion dimension for absolute dimensioning.
X	X axis motion coordinate.
Y	Y axis motion coordinate.
Z	Z axis motion coordinate.
;	Comments.

---

## Incremental Arc Center (%)

The incremental arc center code selects the Fanuc mode for programming arc coordinates. This mode is selected for the entire NC program as well as for any chained programs.

In the Fanuc mode, arc centers are always incremental, regardless of whether the system is in G90 (absolute) or G91 (incremental) mode. In contrast, arc center specifications in EIA-274 mode follow the selected programming mode, absolute or incremental.

You can specify the default arc center mode in the Run Settings dialog box.

**This character must stand alone on the first line of the NC program in which it appears.**

---

## Absolute Arc Centers (\$)

The absolute arc center code selects the EIA-274 mode of programming arc coordinates. This mode is selected for the entire NC program as well as for any chained programs.

In the EIA-274 mode, the mode of programming arc centers follows the selected programming mode; absolute (G90) or incremental (G91). In contrast, arc center specifications in Fanuc mode are always incremental, regardless of whether the system is in absolute or incremental mode.

You can specify the default arc center mode in the Run Settings dialog box.

**This character must stand alone on the first line of the NC program in which it appears.**

---

## Skip (\) and Optional Skip (/)

The Skip and Optional Skip codes allow you to skip particular lines of code in your program.

**To use the Skip code (\):**

Place the code at the beginning of the line you wish to skip. When you run the NC program, the specified line will be skipped.

**To use the Skip code (\) with a parameter:**

**Note:** The optional skip (/) code works only when the Optional Skip parameter from the Run Settings dialog box is on.

Use the Skip code with a parameter to instruct the Control Program to execute the line of code every nth pass. Place the code at the beginning of the line you wish to skip.

The syntax is: \n, where n is the number of passes between executions.

For example, if you want to execute a block of code every 5 passes, place \5 as the first code at the beginning of the block.

**To use the Optional Skip code (/):**

1. Place the code at the beginning of the line you wish to skip.
2. Select the Optional Skip option from the Run Settings dialog box or the Operator Panel.

When you run the NC program, the specified line will be skipped. If you do not select the Optional Skip option in the Run Settings dialog box, the skip code is ignored and the line is executed normally.

**To use the Optional Skip code (/) with a parameter:**

Use the Optional Skip code with a parameter to instruct the Control Program to execute the line of code every nth pass. Place the code at the beginning of the line you wish to optionally skip.

The syntax is: /n, where n is the number of passes between executions.

For example, if you want to execute a block of code every 5 passes, place / 5 as the first code at the beginning of the block.

---

## Compensation Offset Value (D Code)

The D code is used to select a value from the Control Program Offset Table. For example, D1 selects entry number 1 from the Offset Table.

**Use the D code with:**

- ◆ Cutter compensation codes to specify the tool radius.
- ◆ Tool offset adjust codes to specify a consistent increase or decrease in the commanded movement.

Use the Offsets command under the Setup Menu to view and manage the Offsets Table.

---

## Feed Rate (F Code)

Use the F code to:

- ◆ Specify the rate of speed at which the tool moves (feed rate). This can be inches per minute (ipm), or millimeters per minute (mm/pm) depending on the Units setting. For example, F3 equals 3 ipm or mm/pm.

The feed rate should be set to a low value (up to 50 ipm) for cutting operations. Feed rate values are in millimeters per minute (mm/pm) when using metric units. The Control Program limits the programmed feed rate so it doesn't exceed the maximum allowed by the machining center.

- ◆ Specify the number of seconds to dwell when used with the G04 code.

---

## Preparatory Codes (G Codes)

G codes take effect before a motion is specified. They contain information such as the type of cut to be made, whether absolute or incremental dimensioning is being used, whether to pause for operator intervention, and so on.

More than one G code from different groups can appear in each NC block. However, you may not place more than one G code from the same group in the same block.

**The G codes supported by the Control Program fall into the following groups:**

- ◆ The Interpolation Group
- ◆ The Units Group
- ◆ The Plane Selection Group
- ◆ The Wait Group
- ◆ The Canned Cycle Group
- ◆ The Programming Mode Group
- ◆ The Preset Position Group

*Note: More than one G code from different groups can appear in each NC block. However, you may not place more than one G code from the same group in the same block.*

- ◆ The Compensation Functions Group
- ◆ The Coordinate System Group
- ◆ The Polar Programming Group

## The Interpolation Group

The interpolation group allows you to specify the type of motion for interpolation. These G codes are retained until superseded in the NC program by another code from the interpolation group.

**The supported interpolation G codes are:**

- G00** Rapid traverse
- G01** Linear interpolation (default)
- G02** Circular interpolation (clockwise)
- G03** Circular interpolation (counterclockwise)

## The Units Group

By default, an NC program is interpreted using the units of measure (inch or metric) specified using the Units command on the Setup Menu.

The codes in the Units group, G70 (inch) and G71 (metric), are used to override the Units command, for the entire program, or for a single line.

If the code is placed at the beginning of the program before any tool motions are made, that unit of measure is assumed for the entire program. If the code appears in a block of code, the unit of measure is in effect for that block and all following blocks. You can use these codes to switch between inch and metric modes throughout your program at your convenience.

The Fanuc equivalents, G20 (inch) and G21 (metric), can also be used.

## The Plane Selection Group

This group of codes allows you to select different planes for circular interpolation. G17 is the Control Program default.

**The supported Plane Selection Group codes are:**

- G17** Select the X, Y plane for circular interpolation. The arc center coordinates are given by I for the X axis and J for the Y axis.
- G18** Select the X, Z plane for circular interpolation. The arc center coordinates are given by I for the X axis and K for the Z axis.
- G19** Select the Y, Z plane for circular interpolation. The arc center coordinates are given by J for the Y axis and K for the Z axis.

## The Wait Group

Wait Group codes apply only to the block in which they appear. The program does not continue until the wait conditions are satisfied.

The supported Wait Group codes are:

- G04** Dwell (wait): Stop motion on all axes for the number of seconds specified by the F code, then continue the program. Because the F code is used to specify the number of seconds, you cannot also specify a new feed rate in the same block.  
Example: G04F10; Wait for 10 seconds
- G05** Pause: Used for operator intervention. Stop motion on all axes until the operator manually resumes program execution.
- G25** Wait until TTL input #1 goes low before executing the operations on this block. Used for external device synchronization.
- G26** Wait until TTL input #1 goes high before executing the operations on this block. Used for external device synchronization.
- G31** Linear move to specified coordinate; used with H code to specify both the input number and the High or Low condition for stop (designated by the input operator, + or -). The move occurs until an input is triggered or until a coordinate is reached. The move stops short if specified input goes High (if H is positive) or Low (if H is negative). The default is input 1 High.  
You can have the control program go to a specified block (N Code number) if the input meets the required condition. Use a P code to specify the destination, as with the M98 code.  
For example, G31X5Y5H-2P50000 instructs:  
Move (using the current programming mode) to the X and Y given.  
If input 2 goes low during the move, jump to block number 50000.  
If input 2 doesn't go low, continue with the next block in the program.
- G35** Wait until TTL input #2 goes low before executing the operations on this block. Used for external device synchronization.
- G36** Wait until TTL input #2 goes high before executing the operations on this block. Used for external device synchronization.

**G131** Specifically for digitizing with the probe. The user specifies a Z position and a feedrate. The probe moves from its current position to the specified Z position at the specified feedrate (or current feedrate if not specified on the same block). If the probe input is tripped before reaching the specified Z position, a valid point is captured. In either event (point or no point), when the probe stops moving down, it rapids back to the initial Z position.

## The Canned Cycle Group

Canned cycle codes allow you to perform a number of tool motions by specifying just one code. Canned Cycle codes are typically used for repetitive operations to reduce the amount of data required in an NC program. Canned cycle codes are retained until superseded in the program by another canned cycle code.

The supported Canned Cycle codes are:

**G80** Canned cycle cancel  
**G81** Canned cycle drilling  
**G82** Canned cycle straight drilling with dwell  
**G83** Canned cycle peck drilling  
**G85** Canned cycle boring  
**G86** Canned cycle boring with spindle off (dwell optional)  
**G89** Canned cycle boring with dwell

Refer to Section G for more information on these functions.

## The Programming Mode Group

Programming mode G codes select the programming mode, absolute (G90) or incremental (G91). These codes remain in effect until superseded by each other. The default code on program start up is G90.

With absolute programming, all X, Y and Z coordinates are relative to origin of the current coordinate system. With incremental programming, each motion to a new coordinate is relative to the previous coordinate.

The supported Programming Mode codes are:

**G90** Absolute programming mode  
**G91** Incremental programming mode

## The Preset Position Group

The preset position G codes move the tool to a predetermined position, or affect how future motions will be interpreted.

The supported Preset Position codes are:

- G27** Check reference point: This code moves the machine to its home position and compares the reported position against zero to see if any position has been lost. The difference between the reported position and zero is compared to a tolerance value specified using the Setup Program. Use the L code in this block to override the tolerance value in the Setup Program.
- G28** Set reference point: This code moves the machine to its home position and sets the machine position to 0,0,0. The G28 code performs an automatic calibration of the axes.
- G92** Set position: This code works like the Set Position command under the Setup Menu. The X, Y and Z coordinates following a G92 code define the new current position of the tool.
- G98** Rapid move to initial tool position after canned cycle complete.
- G99** Rapid move to point R (surface of material or other reference point) after canned cycle complete.

## The Compensation Functions Group

Use the cutter compensation NC codes to automatically compensate for the variations in a cutting tool's radius and length. Refer to Section H for more information on using cutter compensation.

**The supported Compensation codes are:**

- G39** Corner offset circular interpolation.
- G40** Cancel cutter compensation.
- G41** Left cutter compensation: Enables cutter compensation to the left of programmed tool path.
- G42** Right cutter compensation: Enables cutter compensation to the right of programmed tool path.
- G43** Tool length offset: Shifts Z axis in a positive direction by a value in the Offset Table, specified by an H code.
- G44** Tool length offset: Shifts Z axis in a negative direction by a value in the Offset Table, specified by an H code.
- G45** Tool offset adjust: Increases the movement amount by the value stored in the offset value memory.
- G46** Tool offset adjust: Decreases the movement amount by the value stored in the offset value memory.



- G47** Tool offset adjust: Increases the movement amount by twice the value stored in the offset value memory.
- G40** Tool offset adjust: Decreases the movement amount by twice the value stored in the offset value memory.
- G49** Cancels tool length offset.
- G50** Cancels scaling.
- G51** Invokes scaling.
- G68** Invokes rotation.
- G69** Cancels rotation.

## The Coordinate System Group

Use the coordinate system codes to establish multiple coordinate systems on one work piece to create multiple parts.

For instance, you can run a part program using a typical coordinate system (with the point of origin on the surface of the front left corner of the workpiece), then select another coordinate system which has its origin at a different point on the surface of the workpiece. For an overview of coordinate systems, see page H-27.

There are seven coordinate system codes. One of these codes (G53) is used to rapid to specified machine coordinates. The other six codes allow you to make up to six individual parts on the same workpiece by specifying different work coordinate systems for each part.

The coordinate system codes are G54 through G59, referring to coordinate systems 1 through 6 respectively. These coordinate systems may be set through the Coordinate Systems command on the Setup Menu.

## The Polar Programming Group

The polar programming codes allow you to perform polar programming operations, based on polar coordinates. The polar coordinates are defined by X (radius) and Y (angle in degrees) when programming for the X, Y plane. Refer to Section H of this Guide for more information on using polar programming.

The supported Polar Programming codes are:

- G15 Polar programming ON
- G16 Polar programming OFF

---

## Input Selection Number/Tool Length Offset (H Code)

The H code has multiple uses. It can be used to specify inputs, input state changes, outputs, and offset amounts.

Use the H code in conjunction with:

- ◆ The wait codes G25 and G26, to specify the input number. If the H code is **not** used with these G codes, input 1 is assumed.
- ◆ The wait code G31, to specify input change to high or low. If the H code is **not** used with this G code, input 1 High is assumed.
- ◆ The tool length offset codes G43 and G44, to specify the amount of Z axis shift. (The Offset Table you use for Tool Length Offset H values is the same table you use for Cutter Compensation and Tool Offset Adjust D values.)
- ◆ The transmit codes M25 and M26 for interfacing with robots or other external devices, to specify the output number. If the H code is not used with these M codes, output 4 is assumed.

---

## X Axis Coordinate of Center Point (I Code)

In absolute programming mode (G90), the I code specifies the X axis coordinate of the center point of a circle when using circular interpolation. In incremental mode (G91), the I code specifies the X axis distance from the end of the last motion to the center point of the circle for circular interpolation.

If no I code is specified, the system uses the current X axis location as the X axis center of the arc.

In Fanuc mode, all arc centers are incremental.

The I code is also used with the G51 code to specify the scale factor for the X axis when performing scaling functions, including scaling each axis and mirror scaling. Refer to Reference Guide Section H for more information on using scaling.

---

## Y Axis Coordinate of Center Point (J Code)

In absolute programming mode (G90), the J code specifies the Y axis coordinate of the center point of a circle when using circular interpolation. In incremental mode (G91), the J code specifies the Y axis distance from the start point of motion to the center point of the circle for circular interpolation.

If no J code is specified, the system uses the current Y axis location as the Y axis center of the arc.

In Fanuc mode, all arc centers are incremental.

The J code is also used with the G51 code to specify the scale factor for the Y axis when performing scaling functions, including scaling each axis and mirror scaling. Refer to Reference Guide: Section I for more information on using scaling.

---

## Z Axis Coordinate of Center Point (K Code)

In absolute programming mode (G90), the K code specifies the Z axis coordinate of the center point of a circle when using circular interpolation. In incremental mode (G91), the K code specifies the Z axis distance from the end of the last motion to the center point of the circle for circular interpolation.

If no K code is specified, the system uses the current Z axis location as the center of the arc.

In Fanuc mode, all arc centers are incremental.

The K code is also used with the G51 code to specify the scale factor for the Z axis when performing scaling functions, including scaling each axis

and mirror scaling. Refer to Reference Guide: Section I for more information on using scaling.

**Note:**

All M codes used to turn on a device, such as the spindle, execute at the beginning of the tool motion for that block of NC code.

All M codes used to turn off a device execute after the tool motion for that block is completed.

To avoid confusion, it is sometimes easier to place M codes in a separate block from the motion commands.

---

## Angle of Arc Resolution, Loop Counter (L Code)

The L code specifies the angle of arc resolution in circular interpolation programming. With BENCHMAN, it is only used if a helical motion is executed, or if you specifically enable approximated arcs in that program (M111 command).

Use the L code with:

- ◆ The M98 code as a loop counter for subprograms.
- ◆ The M47 code as a program cycle counter, to repeat a program a specified number of times.
- ◆ The G27 code to specify tolerance with homing commands (this is an LMC-specific NC language extension). The difference between the current position and 0 is compared to a tolerance value specified using the Setup Program; use the L code to override this tolerance value.

---

## Miscellaneous Codes (M Codes)

M codes control a variety of functions while a part program is running. M codes should be placed on separate blocks to avoid confusion over whether an M code is activated during or after a motion command.

**The supported M codes are:**

**M00** Pause: Allows you to place a pause in your code. Acts like a G05 pause.

**M01** Optional Stop: Allows you to place an optional pause in your code. Place an M01 in the block of code where you would like to pause. There are switches to activate or deactivate the Optional Stop code in the Run Settings dialog box and on the Operator Panel.

With Optional Stop on, the M01 works like a G05 pause.

With Optional Stop off, the M01 code is ignored, and the other codes on the block are executed as usual.

**M02** End of Program: Takes effect after all motion has stopped; turns off drive motors, spindle and accessories.

**M03** Spindle Motor On Forward: Activated concurrently with motion specified in the program block; remains in effect until superseded by M04 or M05.

- M04** Spindle Motor On Reverse: Activated concurrently with motion specified in the program block; remains in effect until superseded by M03 or M05.
- M05** Spindle Motor Off: Activated after the motion specified in the program block; remains in effect until superseded by M03 or M04.
- M06** Tool Change: Pauses all operations, turns off spindle, retracts spindle for tool change.
- M08** Coolant On: Turns on coolant; remains in effect until superseded by M09.
- M09** Coolant Off: Turns off coolant; remains in effect until superseded by M08.
- M10** Air Vise On: Unclamps Air Vise; remains in effect until superseded by M11.
- M11** Air Vise Off: Clamps Air Vise; remains in effect until superseded by M10.
- M20** Chain to Next Program: This code is used to chain several NC files together. It appears at the end of a part program and is followed on the next line by the file name of another program which is executed when all motion stops. Here's an example of a part program chain to another program:
- ```

N37 Z.2
N38 M20
PROGRAM2.NC ;CHAIN TO PROGRAM TWO

```
- If the two programs you are chaining are not in the same directory on your computer, you must specify the full path name for the next program file.
- M22** Output current position to file. Typically used in digitizing.
- M25** Set TTL output #1 Off: Used for external device synchronization.
- M26** Set TTL output #1 On: Used for external device synchronization.
- M30** End of program: Same as M02.
- M35** Set TTL output #2 Off: Used for external device synchronization.
- M36** Set TTL output #2 On: Used for external device synchronization.
- M47** Rewind: Restarts the currently running program; takes effect after all motion comes to a stop. Typically used with an L code to repeat a program a set number of times.
- M98** Call to subprogram. Use the P code to specify the subprogram starting block number. Use the L code to specify the number of

times the subroutine is executed. You can nest subprogram calls to a depth of 20.

- M99 Return from Subprogram; Goto
- M105 Operator Message (LMC)
- M122 Output current position to file. Almost identical to M22, except that if a macro (@X@Y@Z) is used to insert a coordinate, the position of the digitized point will be used, rather than the current machine position.

## M22: Output Current Position to File

The M22 code is used to write information to a file while a program is running. Typically, this code is used when digitizing to write the current X, Y, and Z machine coordinates to a file. The proper format for using this code is: `M22(filename)DataToWriteToFile`. The first time the Control Program encounters an M22 code, it opens the specified file. You must enclose the name of the file in parentheses for the Control Program to recognize it. If you do not specify any DataToWriteToFile text, the default data is output. This default is the current position, equivalent to specifying 'X@X Y@Y Z@Z'. Notice that the @X,@Y,@Z 'macros' are replaced by the actual machine position when the data is written. Each M22 code automatically adds a line feed to the end of its output so the next M22 starts on a new line.

If the file name is followed by "A" (e.g., test.nc,A), the Control Program does not delete previous information from the file, it appends the information to the end of the existing information. If the file does not exist, it is created.

If you use more than one M22, only the first occurrence must have the file name in the parentheses. The remaining M22's may have empty parentheses, ( ), or may specify a different file.

If you want to generate more than one file at a time, you must include the filename each time you specify M22. If a filename is not specified, the first file opened is used.

### Example:

```
. . .           ; code to move to position
; Open my1.xyz, discard contents, write coordinates
M22(my1.xyz)
. . .           ; code to move to next position
```

```

; Append to currently open data file
M22()
. . . ; code to move to next position
; Open my2.xyz and append coordinates
M22(my2.xyz,A)

```

Information about digitizing is provided with the digitizing package. For additional information, please call Light Machines Technical Support.

**Special codes that can be used with M22 to generate run-time reports:**

```

@X    Current X position (in current coordinate system).
@Y    Current Y position (in current coordinate system).
@Z    Current Z position (in current coordinate system).
~ (tilde) New Line (starts a new line in the file).
@TD   Time of Day (12 hour) "11:59:59AM"
@TC   Time (elapsed) for cycle "99:11:59" (0's trimmed from
left)
@TT   Time Total (program run) "99:11:59"
@TA   Time Average (per cycle) "99:11:59" ("?:?:?" if first part)
@TL   Current Tool #. "5"
@C    Cycle # (Current Pass) "3"
@D    Date "12/31/94"
@FN   Current File (w/o path) "PART.NC" ("UNTITLED.NC" if
untitled)
\t    TAB
\\    Outputs a single '\' character.

```

**Example:**

```

; Start of file
... ; Process a single part
; Output part time statistics to file c:\Reports\Stats.txt
(c:\Reports directory must exist)
M22 (c:\Reports\Stats.txt,A) Part #@C processed in @TC.
M47 L50 ; We want to process 50 parts.

```

## M99: Return from Subprogram, Goto

The M99 code has two specific uses; it can be used as a command to return from a subprogram or it can be used as a goto command.

**Using M99 with subprograms:**

When used in a subprogram, this code returns you to the block following the last M98 (Call to Subprogram) command.

You can use the P code plus a block number to override the block returned to; however, if this feature is used from a nested subprogram call,

all return targets are discarded. The rules for a Goto target block apply to this use as well.

#### **Using M99 as a Goto command:**

This command can be used in the main NC program as a Goto command to jump to a block on a line before the M02 command.

Use the P code to identify the block number being jumped to. Control is transferred to the first occurrence of this N code; it cannot be used to transfer control between chained programs (see M20).

This command can be used anywhere in the program to change the flow of program execution. It is good programming practice to place this command on a line by itself to improve the program's readability.

## **M105: Operator Message**

This command is used to display messages in the Control Program. It provides a way to display messages to the operator on the Message Bar while an NC program is running. You can also pause the program with a custom message. This code is a non-standard, Light Machines code.

By default, the message is centered, displayed as black characters on a white background, and is persistent (not cleared until the operator manually does so or until the next message is displayed).

#### **The correct format for using this code is:**

`M105(the message);comment`

For instance, the following line of code displays a simple message:

`M105(End of Roughing Segment);Display message in white;continue`

#### **Messages can be altered by using the following alternate characters:**

^ Displays the message and performs a pause requiring operator intervention to continue.

~ Displays the message as a Warning Message.

\b Beeps when the message is shown.

#### **The format for using the M105 code with an alternate character is:**

`M105(alternate character plus the message) ;comment`

For example:



M105(~WARNING);Message in yellow, continue

Here are some other examples of how to use this code:

M105( ) ; clears current message

M105(^Please stop and read this!) ; Normal Message, pauses

M105(~^I MEAN IT!) ; Warning Message, pauses

M105(\b\b\b) ; Clears current message, beeps 3 times, and doesn't pause

---

## Block Number (N Code)

N codes have two uses:

- ◆ To provide destinations for Gotos (M99) elsewhere in the program.
- ◆ To clearly show the organization of the code and improve readability.

Using the N code is optional; however, when you do use the N code, it must be the first character in a block of NC codes.

Other than for the above stated uses, N codes are not recognized by the Control Program. Their presence, absence, or sequential value does not affect the execution of the NC program in any way (unless the target of a goto is missing).

You may have N codes on some blocks and not on others. N code sequence numbers do not have to be in order, but regular sequential order does make it easier to follow the program. The Control Program can change the N codes in a program by inserting, removing, or renumbering them. See Edit Menu, Renumber Command in Section E.

---

## Subprogram Block Number (O Code)

The O code is used to indicate the start of a subprogram, and must be followed by a number which identifies the subprogram. The O code replaces the N code in the first block of the subprogram.

To call a subprogram, use the M98 code; the P code specifies which subprogram to execute. To return from the subprogram, use the M99 code.

Only the first block in the subprogram contains the O code. The remaining blocks may contain N codes. The O and N code numbers may be used to help identify and set apart the subprogram to improve readability, for example:

M98P50000;call to first subprogram

...;after first subprogram is finished, M99 code returns to this point

...

M98P60000 ;call to second subprogram

Note: Full circles (360° arcs) cannot be performed with an R code. Split the arc into two arcs or use center point (I, J and K) values for full 360° circles.

...;after second subprogram is finished, M99 code returns to this point

...

O50000 ;start of subprogram

N50010 ;first line of subprogram

N50020 ;second line of subprogram

N50030M99 ;last line of subprogram

...

O60000 ;second subprogram

N60010 ;first line of second subprogram

N60020 ;second line of second subprogram

N60030M99 ;last line of second subprogram

## Subprogram Reference Number (P Code)

Use the P code with:

- ◆ The G31 code to reference a goto target block.
- ◆ The G51 code to specify a uniform scaling factor.
- ◆ The M98 code to reference a subprogram using the subprogram block number.
- ◆ The M99 code to specify a return block number as a goto target.

## Peck Depth (Q Code)

The Q code is used with the G83 code in canned cycle peck drilling to specify the depth of each peck.

### CAUTION

Using multiple tools is an advanced operation, and should not be attempted by persons unfamiliar with using the machining center.

## Radius of Arc, Drilling Start Location (R Code)

As an alternative to specifying the center point of an arc (I Code, J Code, or K Code) you can specify the arc radius. Use the same value for the radius in both absolute and incremental programming modes.

G02 or G03 specifies the direction of motion.

Positive values for R (radius) are specified for arcs up to 180°. Negative values are used for arcs greater than 180°. Full circle arcs cannot be performed with an R code. Split the circle into two arcs, or use center point (I, J, and K) values for full 360° circles.

Use the R code in canned cycles to specify a Z axis reference point for peck drilling. The point can be at the material surface or at another refer-

ence point. The R code is also used to specify the rotation angle, in degrees, with the G68 code.

Note: Do not place absolute and incremental commands in the same block. For example:

G90X1V1

will not produce the expected motions.

---

## Spindle Speed (S Code)

Use the S code to set the spindle speed from within the NC program. Spindle speed is specified by the address character “S” followed by a parameter that represents the speed in RPM. For example, S750 is the designation for a spindle speed of 750 RPM. For the S code to have affect the spindle must be turned on by the M03 or M04 command. If the spindle is off, the spindle speed is stored and used when the spindle is turned on again within the program. Use the M05 command to turn the spindle off.

---

## Tool Selection (T Code)

T codes specify the tool offset (number) in the Tool Library in multiple tool machining operations. They *do not* specify the Automatic Tool Changer (ATC) station number, but they *do* have an ATC station associated with them. Tools are specified by the address character “T” followed by a parameter that represents the number of the tool. For example, T3 is the designation for tool number three.

---

## X Axis Coordinate (X or U Code)

An X code specifies the coordinate of the destination along the X axis. A U code is used in absolute programming mode (G90) to specify an incremental X motion. You cannot use the U code to mix incremental and absolute programming in the same block.

---

## Y Axis Coordinate (Y or V Code)

A Y code specifies the coordinate of the destination along the Y axis. A V code is used in absolute programming mode (G90) to specify an incremental Y motion. You cannot use the V code to mix incremental and absolute programming in the same block.

---

## Z Axis Coordinate (Z or W Code)

A Z code specifies the coordinate of the destination along the Z axis (spindle axis). A W code is used in absolute programming mode (G90) to specify an incremental Z motion. You cannot use the W code to mix incremental and absolute programming in the same block.

---

## Comment Codes

The Control Program allows you to add *comments* to your NC blocks. The Control Program recognizes two comment codes:

- ◆ A semicolon “;”

- ◆ An open parenthesis “(“

These two comment codes are equivalent. The use of either of these codes at the end of an NC block indicates that a comment follows.

Comments must follow all other NC codes in the block. Comments are ignored when the part program is executed. Comments can be placed on a block without any NC codes to document what is occurring within a program. NC programmers use these comments to annotate their programs.

Here is an example of an NC block with a comment:

```
X0Y0Z0;MOVETOZEROPOINT
```

The comment tells us that the X, Y and Z codes in this block command the cutting tool to move to the zero point (coordinate 0,0,0).

Comments can be combined with the G05 pause and the M06 Tool Change codes to display messages to the operator during program execution. Here is an example of an NC block with a pause coded comment:

```
G05(ROUGHDIAMETERSHOULDBE0.5in.
```

When the program pauses, the program line, and thus the comment, is displayed on the message bar, telling the operator to verify the diameter of the workpiece before continuing. The M105 code provides a more versatile and powerful message facility.

By using the Renumber command you can strip the comments from a program with a single command; however, comments cannot subsequently be replaced automatically.

---

## General Programming Suggestions

The following rules should be followed when writing NC part programs.

- ◆ The sequence of words (address characters plus parameters) in an NC block must appear in the following order: /, N (0), G, X (U), Y (V), Z (W), A, I, J, K, R, Q, H, L, F, S, T, M, P, ; A different order may cause unpredictable results.
- ◆ In many cases, a word need not be repeated in the next block (line). The system assumes no change in codes unless a new code appears. This does *not* apply to: N words, I, J, and K, G04, G05, G25, G26, G92, F used for dwell, M02, M20, M25, M26, M30, M47, M98 or M99.
- ◆ You can use more than one G code in a block; however, you can use only one G code from any one group in a single block.
- ◆ N codes (sequence numbers) are not required in a part program; however, they can be useful in identifying a block when editing a long NC part program.
- ◆ An O code is required to mark the beginning of a subprogram and does not have to be in sequence with the N codes.



# More CNC Programming

**Linear Interpolation Programming**

**Circular Interpolation Programming**

**Rapid Traverse Programming**

**Canned Cycle Programming**

**Subprogram Programming**

# Linear Interpolation Programming

Linear interpolation is the movement of the tool in a straight line from its current position to a coordinate location specified by an NC block. Here's a typical block of NC code using linear interpolation:

**N5G90G01X.7Y1.2F2**

Broken down into individual words:

- N5** The block sequence number is 5
- G90** Coordinates are given using absolute dimensioning
- G01** Linear interpolation is specified
- X.7** X axis coordinate of end point = .7
- Y1.2** Y axis coordinate of end point = 1.2
- F2** Feed rate is 2 inches per minute

The G01 code *is* required when switching from circular interpolation or rapid traverse positioning back to linear interpolation. If we assume the current position of the tool is X.5, Y.5, the tool movement generated by the above block is something like this:

Typical tool movement using linear interpolation

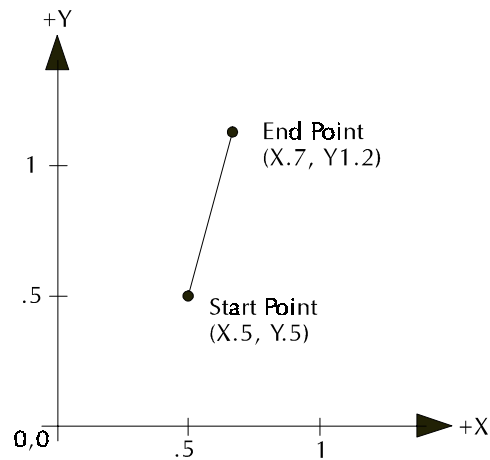

An equivalent movement is achieved with incremental dimensioning (G91):

**N5G91G01X.2Y.7F2**



## Circular Interpolation Programming

Circular interpolation moves the cutting tool along an arc from the starting point specified in one block, to an end point specified in the next block. The curvature of motion is determined by the location of the center point (I, J, or K), which must also be specified in the second NC block.

The direction of rotation from the starting point determines the actual shape of the arc relative to the spindle axis. A G02 code moves the tool in a clockwise (CW) motion from the starting point. A G03 code moves the tool in a counterclockwise (CCW) motion from the starting point.

Here are two typical blocks of NC code using circular interpolation:

G02 (CW) and G03 (CCW) cutting paths

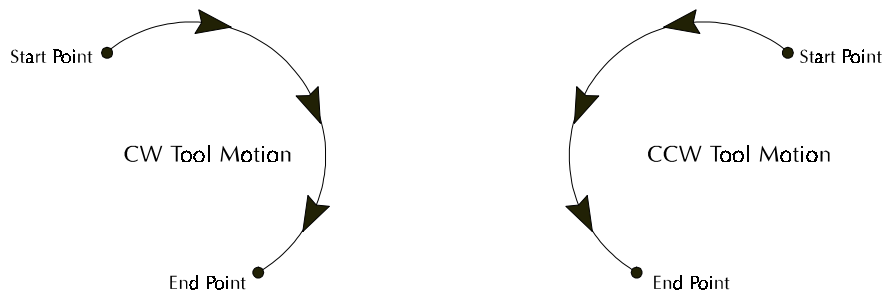

**N9G90X1Y0;SET START POINT**

**N10G03X0Y1I-1J0F2;COUNTERCLOCKWISE TO X0,Y1**

The first block defines the starting point. The second block defines the end point and the center of the arc. Broken down into individual words, the second block reads:

- N10** The block sequence number is 10
- G03** The tool will proceed in a counterclockwise direction from the starting point to specified (X, Y) coordinates; center point of arc is specified by (I, J) coordinates
- X0** X axis coordinate of end point = 0
- Y1** Y axis coordinate of end point = 1
- I-1** I coordinate of center point of arc = -1 (relative to start point)
- J0** J coordinate of center point of arc = 0 (relative to start point)
- F2** Feed rate is 2 inches per minute

The tool path generated by the preceding block is something like this:

Typical tool movement using circular interpolation

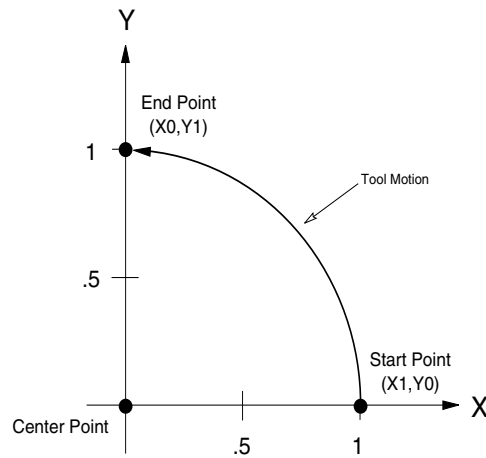

An equivalent movement is achieved with incremental dimensioning (G91):

```
N9G91X1Y0;SET START POINT  
N10G03X-1Y1I-1J0F2
```

In this NC block, the X and Y values are the distance the tool is to move from its current position. In both cases, the I and J values are equal to the X and Y distance from the start point to the center point.

---

## Circular Interpolation on Other Planes

To perform circular interpolation on a plane other than the X, Y plane, use a G18 code to select the X, Z plane, or use a G19 code to select the Y, Z plane. This feature is rarely used in manual part programming, but may be used by CAM systems to generate surfaces of revolution. The G17 code is used to return to the X, Y plane. An example of circular interpolation on the X, Z plane is:

```
N9X0Z0  
N10G90G18G03X0Z1I0K.5F2
```

In this NC block, the X and Z values are the destination position of the tool. The I and K values are the incremental location of the center point of the curvature of motion.

## Helical Interpolation Programming

Helical interpolation is performed when the axis not used in circular interpolation is commanded to move. For example (assuming a start point of 0,0,0):

```
N10G90G03X0Y1Z1I0J.5F2
```

This block would cause the Z axis to move at a constant feed to Z1 while the X and Y axes move in a circular path, resulting in a helical motion. Helical interpolation works with circular motion on the X,Z and Y,Z planes as well.

Here is an example of an NC program using helical interpolation.

```
G90M03S1500  
G0X0Y0Z0.070  
G0X2Y2  
G1Z-0.5F10  
G02X0Y2Z0I-1J0F10  
M02
```

This program uses incremental arc centers. Include the % code if you have changed the Control Program default to absolute.

In the example program, the tool plunges into the workpiece then makes the helical interpolation move to the back corner of the stock (X0Y2Z0).

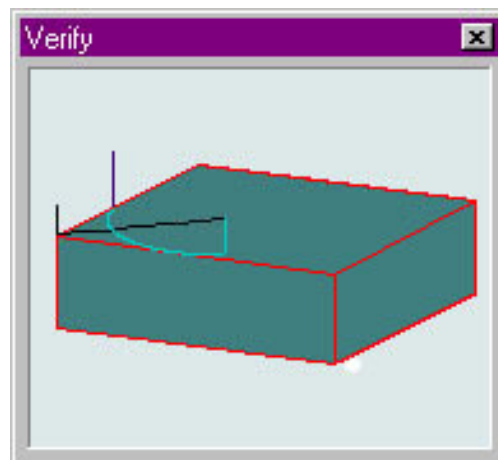

Centerline View

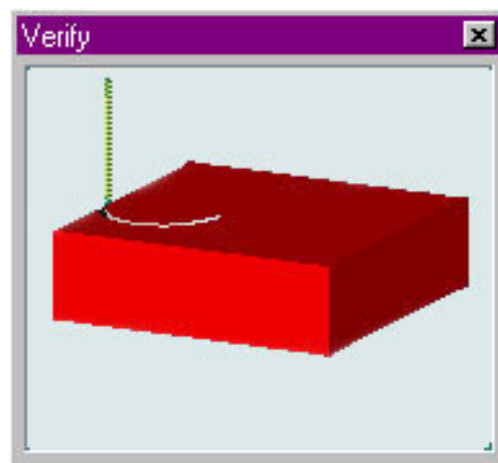

Solid View

## Rapid Traverse Programming

On the Machining Center, the rapid traverse code (G00) can move the tool at the maximum available feed rate (200 ipm) to specified coordinates. Rapid traverse is used to reposition the tool before ending a program, or in preparation for the next cut.

### WARNING

**The tool should not be engaged in a cutting operation while traversing to a new location!**

Rapid traverse can be used for all tool positioning motions. This will reduce the run time for the part program. The G00 code remains in effect until linear (G01) or circular (G02, G03) interpolation is again specified. Linear or circular interpolation resumes at the feed rate last specified prior to the rapid traverse motion(s) unless you specify a new feed rate.

Here's a sequence of typical NC blocks using rapid traverse:

**G90G01X1F2; MOVE IN A STRAIGHT LINE TO X = 1 AT 2 IPM**

**G00X2; RAPID TRAVERSE TO X=2**

**X3; RAPID TRAVERSE TO X=3**

**G01X4; MOVE IN A STRAIGHT LINE TO X=4 AT 2 IPM**

---

## Canned Cycle Programming

Canned cycle commands allow you to perform drilling operations by specifying just a few codes. They are typically used for repetitive operations to reduce the amount of data required in an NC program. Canned cycle codes are retained until superseded in the program by another canned cycle code. The supported canned cycles codes are:

- G80** Canned cycle cancel
- G81** Straight drilling
- G82** Straight drilling with dwell at bottom
- G83** Peck drilling
- G85** Boring cycle
- G86** Boring cycle with spindle off (dwell optional)
- G89** Boring cycle with dwell

These codes are used in conjunction with canned cycle codes:

- G98** Rapid to initial position after canned cycle complete; this is the system default
- G99** Rapid to point R after canned cycle complete
- Q Code** Specifies the depth of cut. In peck drilling each peck uses the same Q value. The Q value is always positive. If a negative value is specified, it is converted to a positive value.
- R Code** Used for specifying a starting reference point for peck drilling. The point can be at the material surface or at another reference point.

---

## Using G80

To cancel a canned cycle, use the G80 code. This code cancels the currently running canned cycle and resumes normal operation. All other drilling data is cancelled as well. You can also cancel canned cycles by using a G00 or G01 code; a G80 is automatically performed before the G00, G01, G02, or G03.

## Using G81

The G81 code performs straight drilling operations. By specifying an R value of zero, the tool will return to the initial point after drilling to point Z. Here is a sample G81 program.

```
G0X1Y1Z.1;RAPID TO 1, 1, .1
```

```
G81G98Z-.5R0F2;DRILL TO DEPTH OF -.5, RAPID TO INITIAL POINT
```

```
G80;CANCEL CANNED CYCLE
```

```
M2;END PROGRAM
```

This program will generate tool motions similar to this:

If we specified a G99 here instead of a G98, the tool would rapid to point R instead of the initial point.

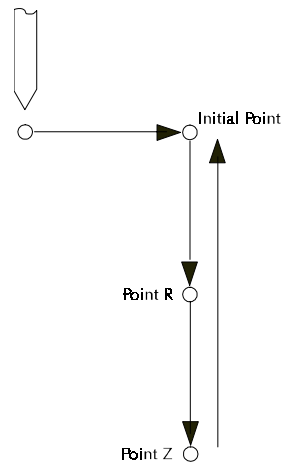

More than one canned cycle can be accomplished by specifying only X and Y coordinates. For example:

```
G0X1Y1Z.1;RAPID TO 1, 1, .1
```

```
G81G98Z-.5R0F2;DRILL TO DEPTH OF -.5, RAPID TO INITIAL POINT
```

```
X.5Y1;PECK AT NEW X,Y COORDINATES
```

```
X.25Y1;PECK AT NEW X,Y COORDINATES
```

```
G80;CANCEL CANNED CYCLE
```

```
M2;END PROGRAM
```

---

## Using G82

A G82 works just like a G81, except it is used when you wish to incorporate a dwell (P code) at the bottom of the hole (point Z). A block of code utilizing the G82 and P code, and the tool motion it creates are shown below.

```
G0X1Y1Z.1;RAPID TO 1, 1, .1
```

```
G82G98Z-.5R0P5F2;DRILL TO DEPTH OF -.5, RAPID TO INITIAL POINT AFTER A DWELL OF FIVE SECONDS
```

```
G80;CANCEL CANNED CYCLE
```

```
M2;END PROGRAM
```

If we used a G99 with the G82 instead of a G98, the tool would rapid to point R instead of the initial point.

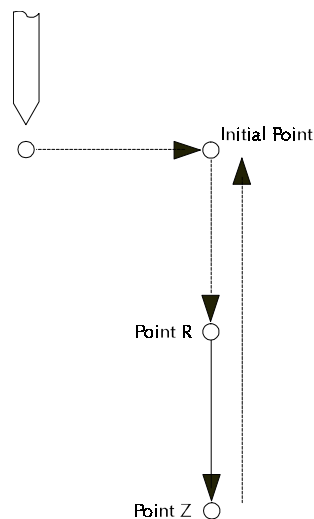

---

## Using G83

The G83 code is used for peck drilling cycles. By adding a Q depth to the code block, you can specify drilling increments. For instance, the following code will peck drill to a depth of -.5 in .1 increments. The tool will rapid back to point R after each peck drill. Also, before each peck the tool will rapid to .005 (.13mm) above the start point.

```
G0X1Y1Z.1;RAPID TO 1, 1, .1
```

```
G83G99Z-.5R0Q.1F3;PECK DRILL TO DEPTH OF -.5, RAPID TO R
```

```
G80;CANCEL CANNED CYCLE
```

```
M2;END PROGRAM
```

G99 returns the tool to point R. Use G98 with the G83 to return the tool to the initial point at the end of the canned cycle.

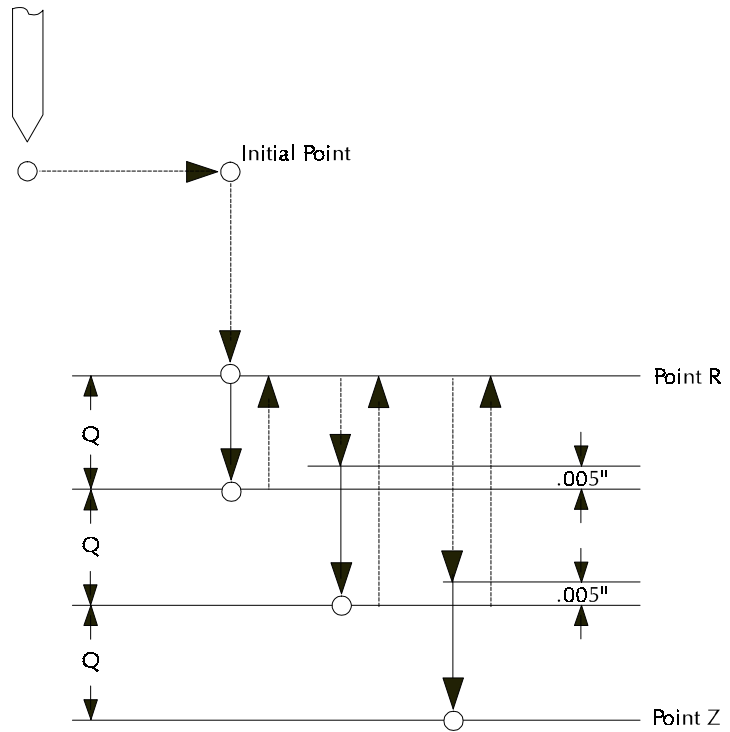

## Using G84

A G84 is used for tapping threads. You specify the depth of the tapped hole. When the tap reaches that depth, it is pulled out in at a rate 1.6 times the rate of insertion (60% faster). The G84 tells the computer to calculate the insertion/extraction ratio. You must use a tapping head with a reversing mechanism when using G84.

**G0X1Y1Z.1;RAPID TO 1, 1, .1**

**G84G98Z-.5R0F2;TAP TO DEPTH OF -.5, RAPID TO INITIAL POINT**

**G80;CANCEL CANNED CYCLE**

**M2;END PROGRAM**



---

## Using G85

A G85 specifies a boring cycle. After the tool plunges, it retracts at the same feed to point R. This sometimes gives a better surface finish on the hole. Then the tool rapids to the initial point.

G0X1Y1Z.1;RAPID TO 1, 1, .1

G85G98Z-.5R0F2;BORE TO DEPTH OF -.5, RAPID TO INITIAL POINT FROM POINT R

G80;CANCEL CANNED CYCLE

M2;END PROGRAM

If G99 were specified instead of G98, the tool would not rapid back to the initial point. It would remain at point R.

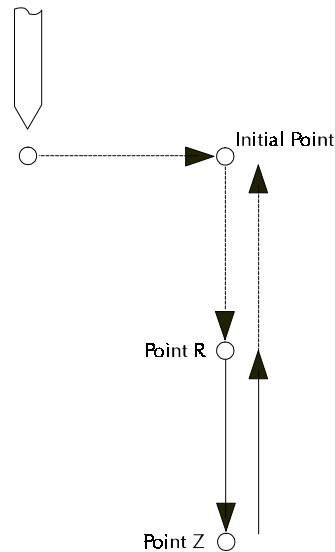

---

## Using G86

A G86 works like a G82 except the spindle stops at the bottom of the hole. The dwell (optional) allows the spindle to come to a complete stop before the tool rapids back to the initial point.

G0X1Y1Z.1;RAPID TO 1, 1, .1

G86G98Z-.5R0P5F2;DRILL TO DEPTH OF -.5, SHUT OFF SPINDLE, RAPID TO INITIAL POINT AFTER A DWELL OF FIVE SECONDS

G80;CANCEL CANNED CYCLE

M2;END PROGRAM

If a dwell is not specified (P code not used), a G05 pause is executed after the spindle stops at the bottom of the hole.

If G99 were used with the G86, the tool would not rapid back to the initial point. It would go to point R.

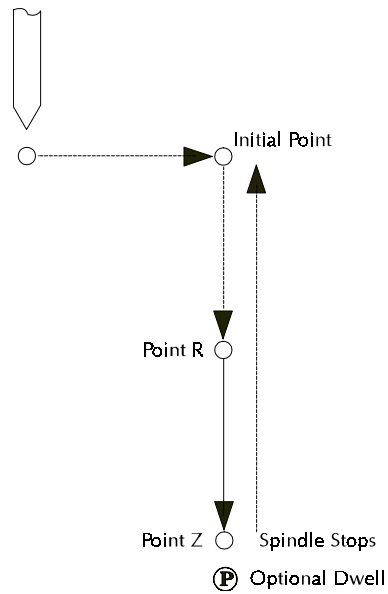

## Using G89

The G89 code works like the G85 except it utilizes a dwell at the bottom of the hole.

G0X1Y1Z.1;RAPID TO 1, 1, .1

G89G98Z-.5R0P5F2;BORE TO DEPTH OF -.5, PAUSE FOR FIVE SECONDS THEN RAPID OUT FROM POINT R

G80;CANCEL CANNED CYCLE

M2;END PROGRAM

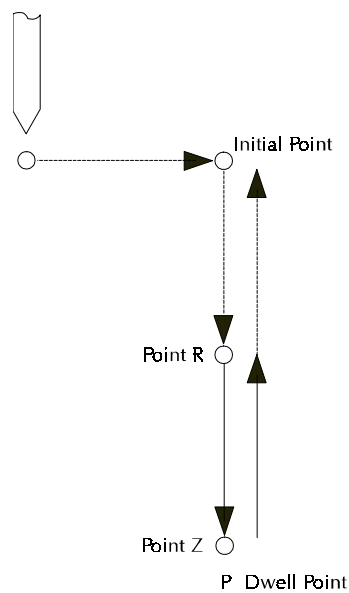

## Subprogram Programming

Subprograms are used to execute repetitive routines in an NC program. Since a subprogram can be called again and again, you don't have to enter the same data more than once. This is especially useful if the machining operation you wish to repeat is lengthy or complex. The NC codes used for subprogramming on the Machining Center are:

**M98** Call to subprogram.

**M99** Return from subprogram.

**P Code** The P code is used to reference the first block of the subprogram (which begins with an O code). The P code immediately follows an M98.

**L Code** The L code is used as a loop counter when used in subprogramming. The computer executes the subprogram as many times as defined by the L code. For instance, if the code is L5, the subprogram is executed five times. (Optional)

**O Code** The O code replaces the N code on the first block of a subprogram.

A subprogram is *called* by an M98 and a P code. When an M98 calls the subprogram, the main program is interrupted while the subprogram is executed.

The P code references the subprogram's address (the first block of the subprogram). The first block of the subprogram uses an O code instead of an N code for block numbering.

When the M99 is executed, the main portion of the NC program continues to execute from the block after the subprogram was called.

Subprograms can also be *nested* within other subprograms. This means that while a subprogram is being executed, it can call another subprogram. The default number of levels that subprograms can be nested is 20 levels deep. You can change the default by using the Setup Program (click on the Setup icon in the BENCHMAN program group).

Note: The L code is also used as a program cycle counter. For instance, if the last block of NC code in your program is M47L10, the program executes ten times. After the tenth time, the computer ignores the rewind and runs the remainder of the program.

Note: You can also perform an M99P "block number" at the end of the subprogram. This returns to the main program at the specified block. It's like a return with a go to.

## A Sample NC Subprogram

```
G05
M03S1000
; SAMPLE OF SUBPROGRAM
; USE 7.25 X 3.00 STOCK FOR VERIFY
GOX1Y1Z.1; RAPID TO 1, 1, .1
M98P1000L4; RUN SUBPROGRAM 1000 FOUR TIMES
G90G0X0Y0Z.1
M2; END OF MAIN PROGRAM
O1000; SUBPROGRAM TO MILL SQUARE AND MOVE TO NEXT POINT
G90G1Z-.1F2; PLUNGE AT CURRENT LOCATION
G91; INCREMENTAL COORDINATE
X1F5; FIRST MOVE, FEED RATE 5
Y1; SECOND MOVE
X-1; THIRD MOVE
Y-1; FOURTH MOVE
G90G0Z.1; RAPID UP ABOVE WORK
G91X1.5; RAPID TO START OF NEXT SQUARE
M99; RETURN FROM SUBPROGRAM
```

---

The M98 calls the subprogram that begins on block O1000 (referenced by P1000) and tells it to repeat four times.

# Advanced CNC Programming

Using Polar Programming

Using the Homing Commands

Using Cutter Compensation

Using Scaling and Rotation Codes

Multiple Tool Programming

Understanding Coordinate Systems

Using Tool Length Offset Codes

Using Tool Offset Adjust Codes

## Using Polar Programming

Using polar coordinates allows you to specify a radius and an angle by specifying a G16 code (polar programming on), then X and Y codes. The X code specifies the radius. The Y code specifies the angle in degrees. A G15 is used to cancel the polar programming mode. This programming method can be used in both absolute and incremental programming.

Polar programming is especially useful when writing programs for machining bolt holes. An L code can be used as a multiplier for the angle value. For instance, this bit of code:

```
G0X0Y0Z0.07
M03
G16
G91X2Y0
M98P1L12
M2
O1Y30
G81Z-.1R0
G80
M99
```

combines the use of polar programming with a canned cycle and a subprogram to drill a hole at 30° increments. The L value was determined by dividing 360 degrees by 30.

You can also cut an arc using code similar to:

```
G16
G91X2Y0
M98P1L360
G15
M2
O1Y1
M99
```

In polar programming, the center point is the origin if you specify G90 and the radius (X code). The center point is the current center if you specify only the angle (X and Y codes). The center point is the current point if you specify G91 and the radius (X code).

Note: On all ATC equipped machines, you must home the machine each time the machine is started.

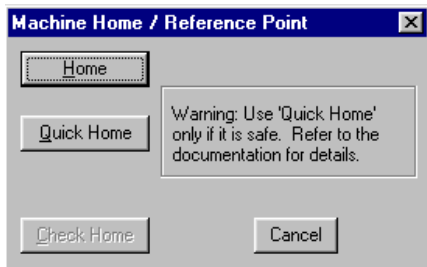

G28 sets a machine reference point, similar to the Set/Check Home command from the Machine Menu.

## Using the Homing Commands

The Homing commands allow you to establish a point of origin at the ends of travel on the Machining Center. The Machining Center then uses this point as a reference for all machine coordinate movements. The Machining Center can then move consistently to the same location when programmed to do so.

## Using G28

The G28 code “homes” the machine: It moves the machining center’s spindle, cross slide, and saddle to the ends of travel along each axis and sets the Machine Coordinate System to (0,0,0). This zero point is located at the positive limits of the X, Y, and Z axes. Use G28 to automatically initialize the machine every time it’s turned on. See the sample NC program below for one use of the G28 code.

## Using G28 in an NC Program

Here is an example of an NC program using Homing commands (the Homing commands and related commands are in italics):

```
G28; HOMING THE MACHINE  
M3S1000; SPINDLE MOTOR ON SPEED 1000  
G54; USE COORDINATE SYSTEM ONE  
G0X0Y0Z0; RAPID TO 0,0,0  
G1Z-0.070F5; CUTTING THE PIECE  
G1X3  
G1Y4.25  
G1X0  
Y0  
G0Z0.070  
M2
```

The G28 code homes the machine and sets the Machine Coordinates and World Coordinates to zero. Use a G27 if you want to check the home position, but do not want to set that position to zero.

The G54 calls up Coordinate System One (CS1), which contains the offset values relative to the machine’s home position. These are the values you entered for Coordinate System One in the Setup Coordinate Systems dialog box. The coordinates in the Position Window on the screen change to the coordinates of Coordinate System One

The next line (`G0X0Y0Z0`) calls for the machine to perform a rapid traverse motion from the Home position to point 0,0,0 in Coordinate System One.

The remaining lines of code instruct the machine to cut a square in a piece of stock.

## Using G28 Before Setting Soft Limits

Remember, Soft Limits are based on Machine Coordinates. You can not use Soft Limits until you have set the machine to the reference point using the G28 code or pressing the Home button in the Machine Home / Reference Point dialog box (access using the Set/Check Home command under the Setup Menu).

---

## Using G27

After you have set a reference point (using either the Setup Coordinate Systems dialog box or a G28 code) you can use the G27 code to check the actual machine position against the expected machine position. This command causes the machine to perform a homing-like function, moving each axis independently from its current position to the reference point. The Control Program then compares the current position to the one set by the G28. If the deviation is larger than a threshold you can specify in the SETUP file, the Control Program reports an error after all axes are checked. If there is no deviation, the program continues.

G27 also takes an optional position specified by XYZ. This position is called the *intermediate position*. You do not need to specify all axes for the intermediate point, but for each axis that you specify the current coordinate for the intermediate point is updated to that value. Only axes that have specified coordinates move when you specify an intermediate point. For example, if the first intermediate point commanded is `G27Z.6`, the intermediate point motion is only to move the Z axis to .6. The machine first moves to the current intermediate point at rapid traverse, then performs the reference point check.



## Using G29

The G29 code moves the tool at a rapid traverse rate to a coordinate specified by XYZ. If you have set an intermediate point on one or more axes, the machine first rapids from the current position to the intermediate point then continues to the specified destination. If you command a G29 code in Incremental mode, your specified XYZ point is relative to the intermediate point. If you have not specified an intermediate point, your specified XYZ point is relative to the current position. Use the G29 code after a G28 command to return the tool to a position closer to the part. The example below shows the use of a G28 code and a G29 code.

```
N1G28X2Y2Z-1; INTERMEDIATE POINT THEN HOME  
N2G29X4Y1Z1; GO TO G29 POINT
```

In block N1, the tool moves from its current point to the intermediate point, then to the reference point.

In block N2, the tool moves from the reference point, through the intermediate point, to the new point established by the G29 code.

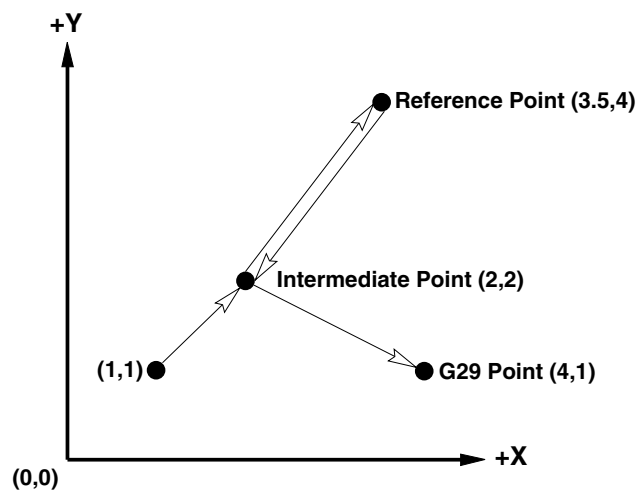

# Using Cutter Compensation

Cutter compensation automatically adjusts the VMC-4000 to compensate for variations in a cutting tool's radius. It uses values from the Offset Table (tool radius values) to determine the compensation offset value. Use the following codes for cutter compensation:

- G39** Inserts an arc at the corner of compensated path
- G40** Cancels cutter compensation
- G41** Invokes left cutter compensation
- G42** Invokes right cutter compensation
- D** Compensation offset value (Tool Radius Value)

Determine left and right cutter compensation in relation to the direction of the tool path. Use left compensation when you need to move the tool to the left of the programmed tool path. Use right compensation when you need to move the tool to the right of the programmed tool path.

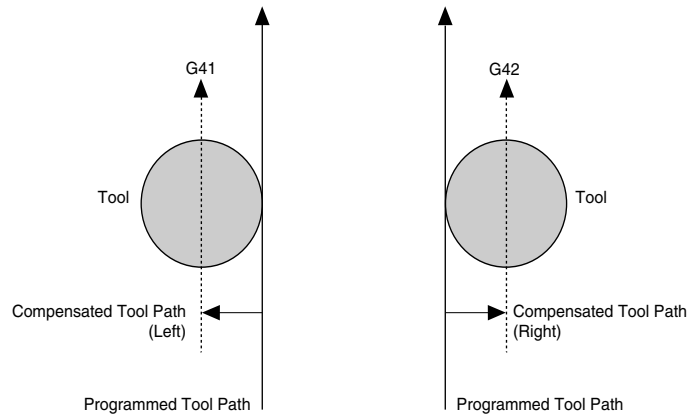

---

## IMPORTANT!

---

The Offset Table you use for Cutter Compensation D values is the same table you use for Tool Length Offset H values.

Select compensation offset values for D from the Offset Table. You can store 200 offset values in the table. Remember, however, that these offset values are the same values you use for adjusting tool length offsets.

## Starting Cutter Compensation (G41/G42)

Cutter compensation mode begins when the following are met:

- ◆ A G41 or G42 code is commanded.
- ◆ The specified offset number is not 0.
- ◆ A move in any of the axes in the offset plane is commanded. The move is not 0.
- ◆ No arc commands are commanded in the start up block.

You can start cutter compensation by inserting a G41 (for left compensation) or G42 (for right compensation) into your NC program. In the example below, left cutter compensation is enabled and the compensation value is equal to offset value 1 from the Offset Table.

```
G0X0Y0
G91; INCREMENTAL
G41D1; CUTTER COMP ON
G1X.25Y.25; MOVE TO P1
G1X0Y1; MOVE TO P2
G1X.75Y0; MOVE TO P3
G1X.25Y-.25; MOVE TO P4
G1X0Y-.75; MOVE TO P5
```

The following illustrations show how the Control Program constructs the compensated tool path for the NC code above:

1. This is the programmed tool path before cutter compensation is enabled. The tool sits at the start point waiting for the first motion command.

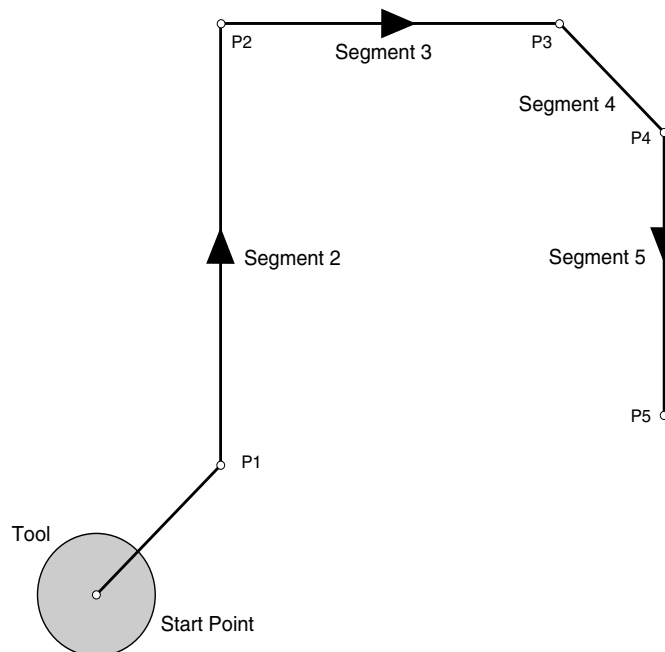

2. Because segment 1 begins before cutter compensation is enabled, the start point of segment 1 is on the original tool path. When cutter compensation is enabled, the Control Program creates Offset Vectors perpendicular to each segment of the programmed tool path to determine the compensated tool path.

Point A' is located at the intersection of the Offset Vector of segment 2 and a point offset by the value of D on the Offset Vector of segment 1. Point A is located on a path parallel to the tool path, offset by the value of D.

Before beginning each motion, the Control Program looks ahead to the next motion in the NC code to determine the compensated end point of the first motion.

Using this method, the Control Program determines that point A is the end point of the first motion. The tool moves to point A on the compensated tool path.

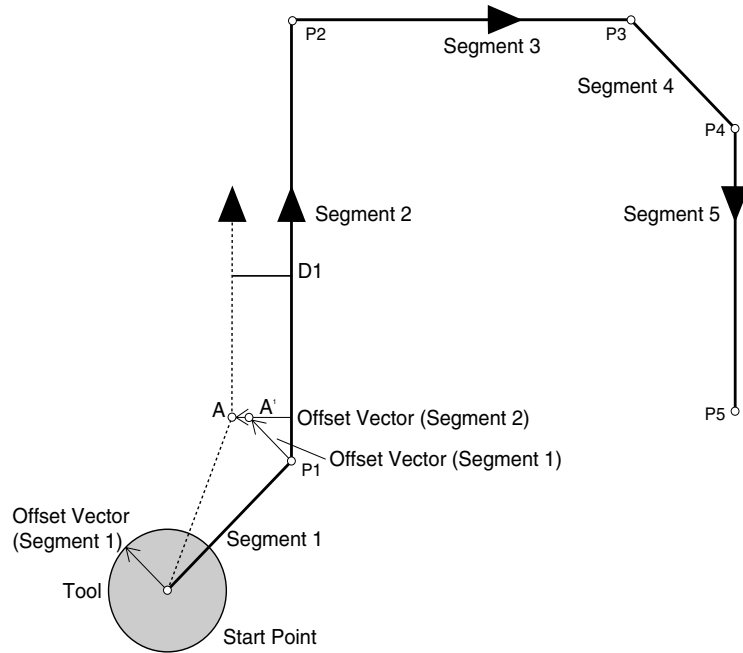

3. The tool moves to the end point of segment 2 (point B) on the compensated tool path. Point B is the intersection of lines drawn perpendicular to the Offset Vectors of segments 2 and 3 with an offset value of D from the programmed tool path.

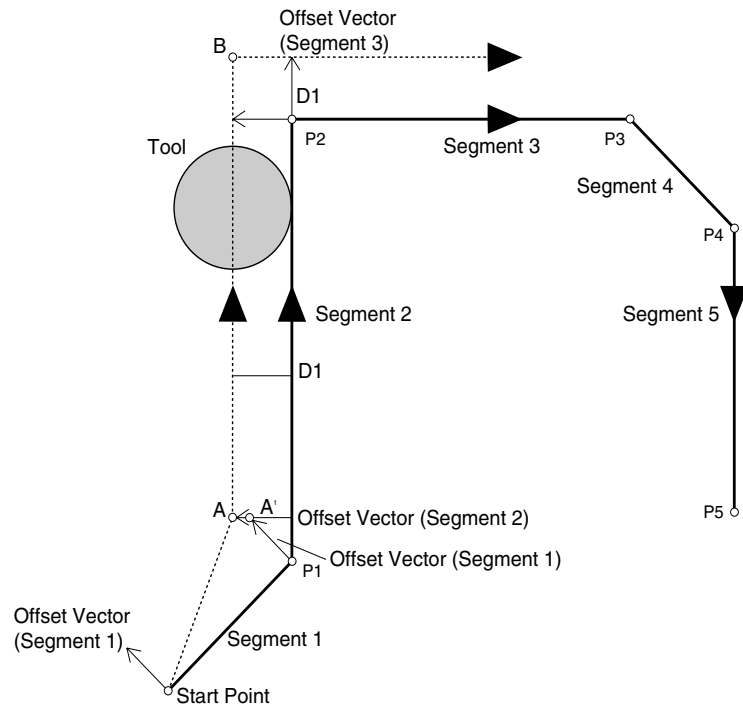

4. The tool moves to the end point of segment 3 (point C), which is located at the intersection of lines drawn perpendicular to the Offset Vectors of segments 3 and 4 with an offset value of D. The tool then begins travel towards point D, the end point of segment 4.

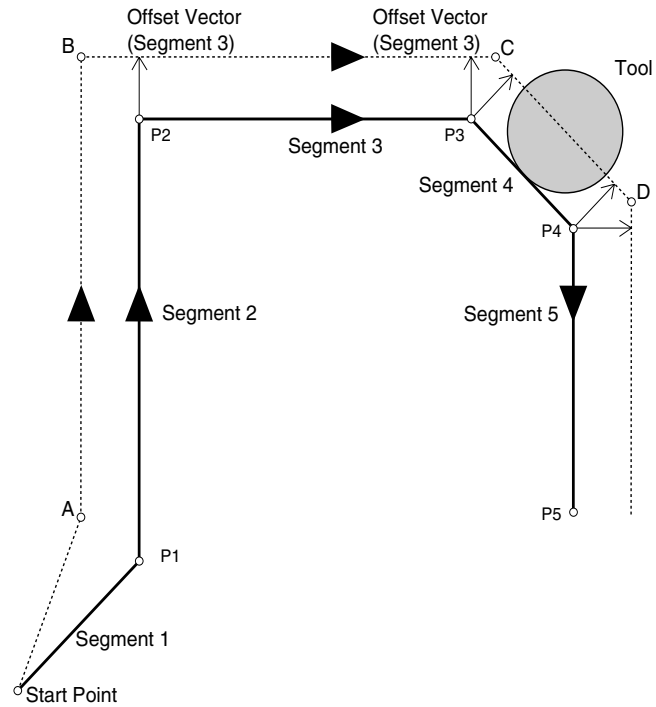

5. The tool moves to the end point of segment 5 (point E) on the compensated tool path. Point E is a point on the compensated path. (See *Canceling Cutter Compensation* in this section for more information.)

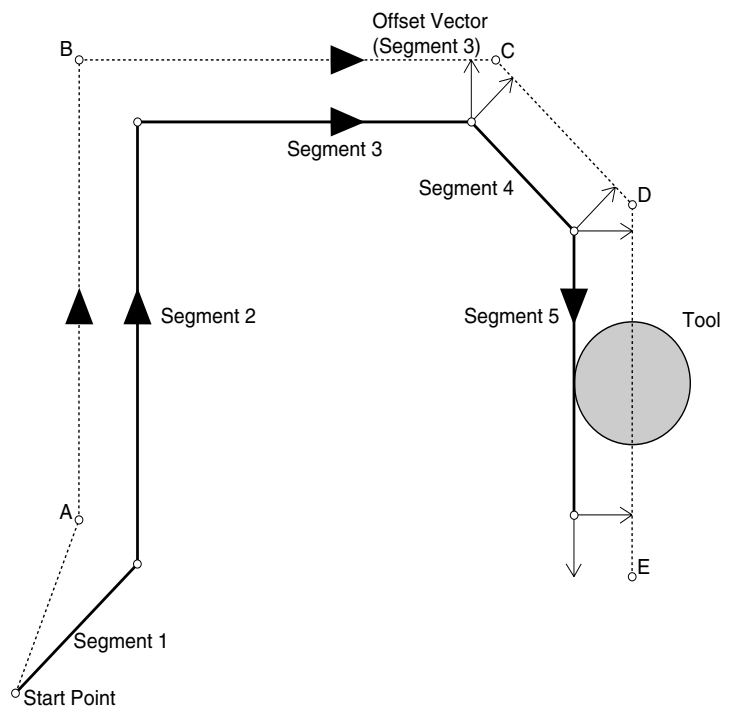

## Cutter Compensation with IJK Vectors

Any G41 or G42 command can include an IJK vector, which defines the end point direction vector and the end point offset vector. For example, if, for segment 3 of the previous illustration, we had specified

G41X.75I1J1

instead of just

X.75

the compensated tool path would look like this:

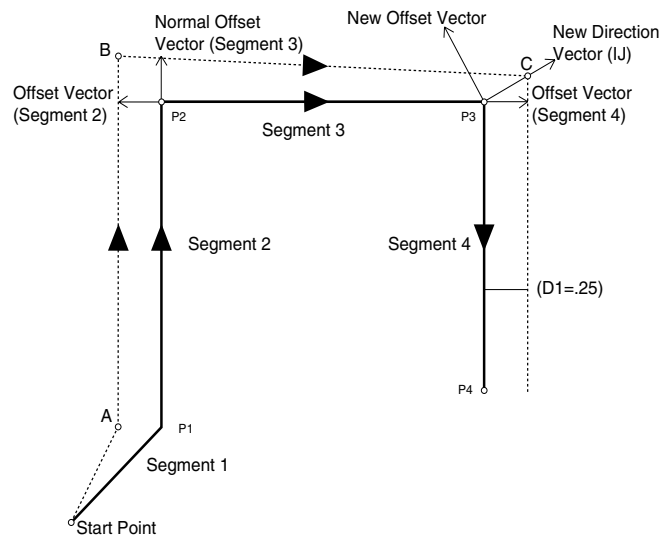

The IJK Vector represents an incremental direction (the length of the vector is not important. For example, I1J2 $\Leftrightarrow$ I3J6. By default, the end direction vector is tangent to the segment.

## Setting Cutter Compensation Offsets (D)

Select Setup Offsets from the Setup Menu to set the value for D (the cutter compensation offset value). The following dialog box appears:

Note: You cannot assign a value to offset number 0. The offset value for offset number 0 is always zero.

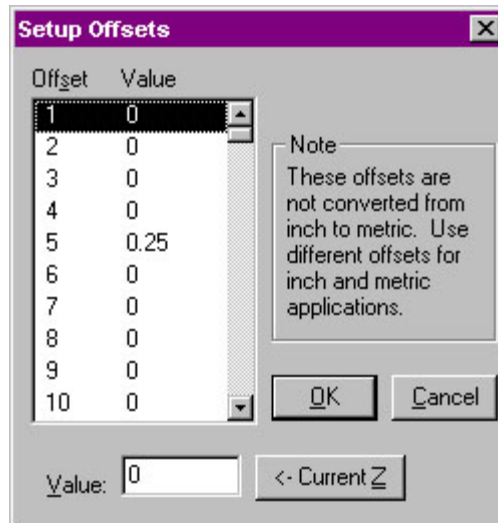

Select an offset to modify from the list. Change its value in the Value Edit box, or use the Current Z button to use the current Z position.

## Changing Offset Values

While cutter compensation is active, you can change offsets by specifying a new offset number with the D code. For example:

```
N1G91  
N2G41D1X.25Y.25  
N3Y.25  
N4X.25D3; USE OFFSET #3  
N5Y-.25
```

...

In this example, the offset number changes from 1 to 3 in line N4. Because the value of offset 3 is greater than the value of offset 1, the compensated path moves farther away from the programmed path and is at the new offset value by the time the tool reaches point C.

In this example: D1=.01 and  
D3=.03

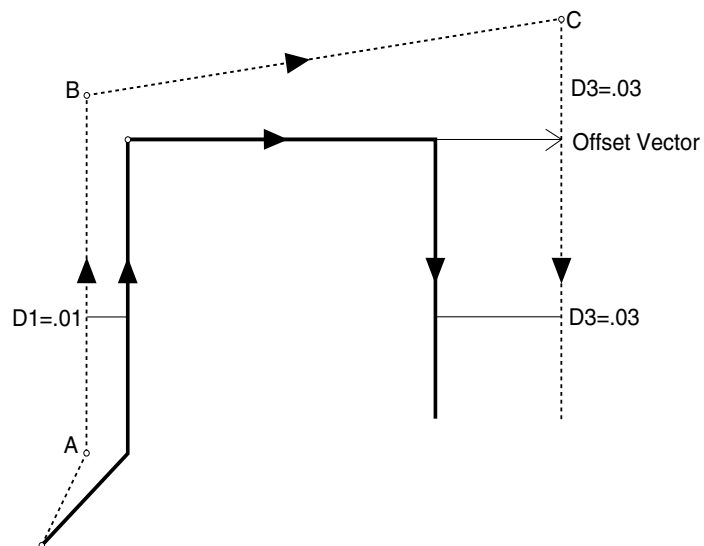



## Changing Offset Sides

You can change the side of compensation sides during cutter compensation. For example, you can start cutter compensation to the left then change to the right while in cutter compensation:

```
G91  
G41D1X.25Y.25; LEFT CC ON  
Y.25  
G42X.25; RIGHT CC ON  
Y-.25
```

...

In this example, left cutter compensation is on at point A, but right cutter compensation begins as the tool moves towards point B. In this case, the offset value (D) is the same for both left and right cutter compensation.

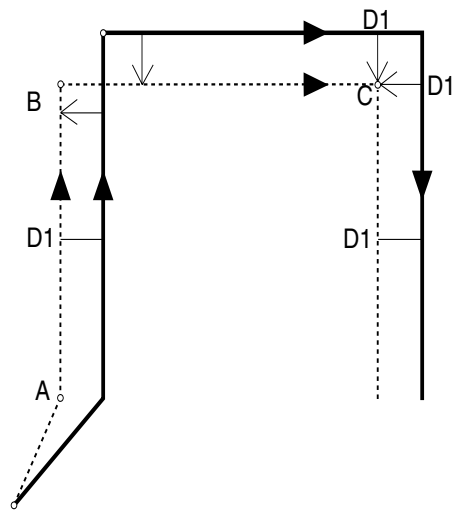

The same situation would occur if you made the offset value negative. For the example above, changing the D value from .01 to -.01 would produce the same result as changing from G41 to G42.

## Using Corner Offset Circular Interpolation (G39)

The G39 code inserts an arc at the corner of a cutter compensated tool path. The G39 instructs the cutter compensation function to complete the current segment by moving to its default endpoint (the endpoint of the Offset Vector). It then creates an arc (with a radius equal to the offset value), starting at the buffered segment's default endpoint, and ending at the endpoint of the offset vector (IJ). Here is an example of an NC program using G39:

```
G91  
G41D1...  
...  
Y.25  
X.25  
G39I0J-1; CORNER OFFSET
```

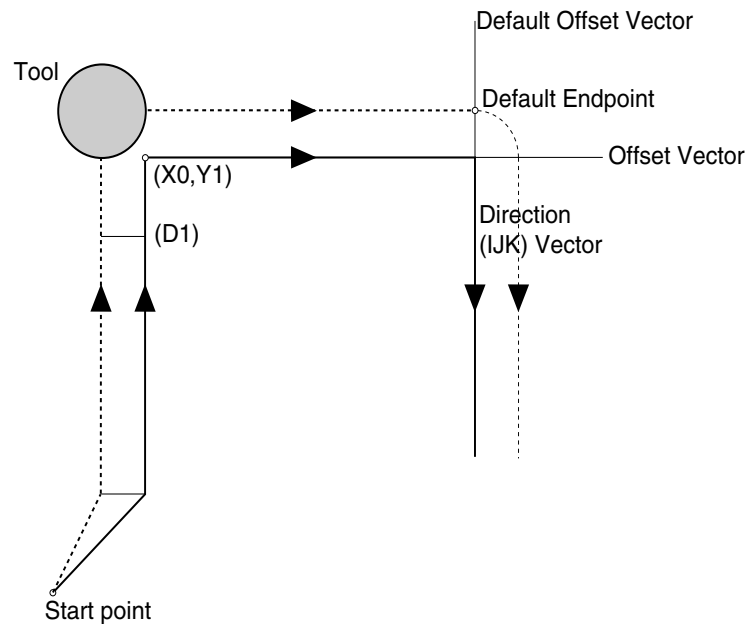

## Canceling Cutter Compensation

Use the G40 code to cancel cutter compensation. G40 is effective for only one move. There are six methods for cancelling cutter compensation.

1. G40
2. G40XYZ
3. G40XYZIJK
4. D0
5. D0XYZ
6. G41/42D0XYZIJK

With methods 4 through 6 above, setting the offset number to zero has the same effect as cancelling cutter compensation. However, cutter compensation is still active.

### Methods 1 and 4

With method 1 the G40 code cancels cutter compensation. The cutter moves from the offset path to the programmed end point. The same occurs with method 4, where you set the D value to zero.

```
G91G41D1
...
X.25
Y-.25
Z.2; RETRACT
G40; OR D0
X-.5Y-.25
M2
```

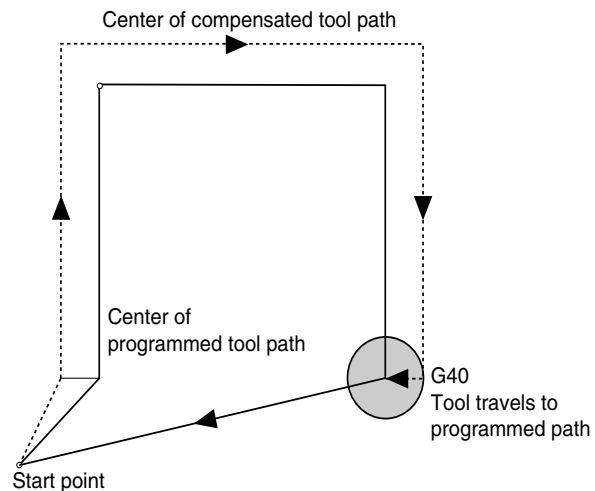

## Methods 2 and 5

With methods 2 and 5, the G40 (or the D0) cancels the cutter compensation, but a subsequent motion (X-.5Y-.25) is included in the program. The tool moves towards the programmed path in the direction of X-.5Y-.25.

G91G41D1

...

X.25

Y-.25

Z.2;RETRACT

G40X-.5Y-.25

M2

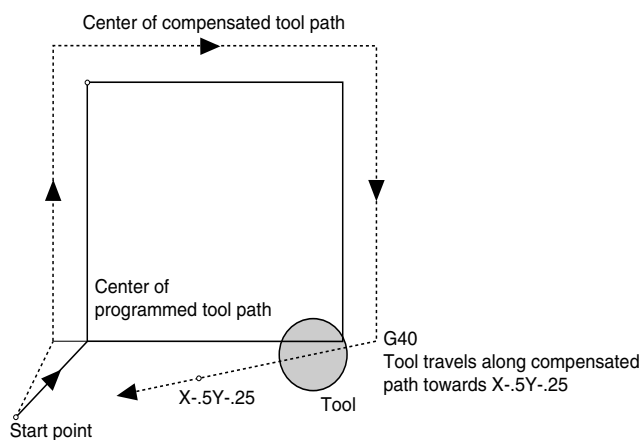

## Methods 3 and 6

With these methods an IJK vector specifies the direction of movement after cutter compensation is cancelled.

G91G41D1

...

X.25

Y-.25

Z.2; RETRACT

G40X-.5Y-.25I-.5J-.25

M2

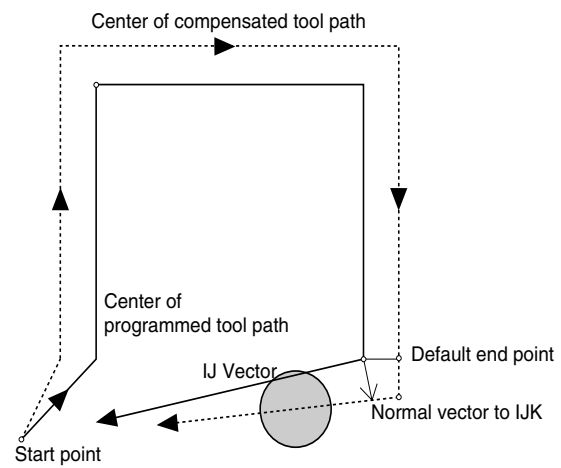

---

# Using Scaling and Rotation Codes

Scaling codes and rotating codes can be used separately or they can be combined. Each of these functions is described in the following paragraphs.

---

## Scaling

Use the scaling codes to scale one or more axes of a part from a fixed scaling origin. You can scale the entire piece uniformly, or set different scaling factors for each axis. Use the following codes for scaling:

- G50 Cancels scaling
- G51 Invokes scaling
- P Uniform scale multiplier

## Uniform Scaling

Use a P Code to scale an entire piece uniformly along each axis. When you specify a value for P, subsequent motions are scaled by that value, starting from the scaling center. The Control Program measures the distance from the scaling center to the start and end points of the shape, then multiplies those values by the P value.

The NC program below creates a half-circle then scales those motions by two to create a larger, uniformly-scaled half-circle (the scaling codes are in italics):

```
N0G0Z.5
N1X1Y1.5
N2G1Z-.1F10
N3G2Y.5J-.5
N4G0Z1
N5G51X1Y1ZOP2; SUBSEQUENT MOTIONS SCALED BY 2
N6G0Z.5
N7X1Y1.5
N8G1Z-.1F10
N9G2Y.5J-.5
N10G0Z1
N11G50; CANCEL SCALING
```

The values for X, Y, and Z in line N5 represent the absolute position of the scaling center. The P value represents the scale factor. In this example, the entire part is scaled by two. The G50 in line N11 cancels the scaling.

---

### CAUTION

---

Using a P Code to scale an entire piece will affect the Z axis, which will affect your programmed depths of cuts. Use caution when performing scaling operations.

Note: If you do not specify any of the coordinates for the scaling center, the current position for unspecified axes becomes the scaling center coordinate.

In this example, a uniform scaling factor for all axes produces a shape scaled from the original.

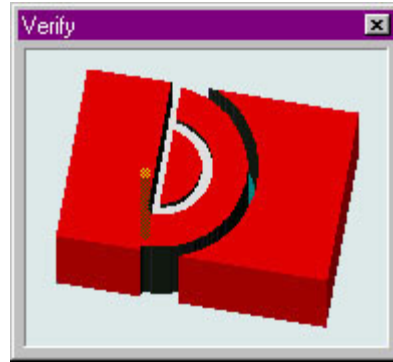

## Scaling Each Axis

You can scale each axis by different magnifications. The following NC program uses scaling to change the proportions of a motion by scaling each axis separately (the scaling codes are in bold print):

```
N0G0Z.5  
N1X1Y1.5  
N2G1Z-.1F10  
N3G2Y.5J-.5  
N4G0Z1  
N5G51X1Y1Z0I1.5J1.75K1; SCALING ON  
N6G0Z.5  
N7X1Y1.5  
N8G1Z-.1F10  
N9G2Y.5J-.5  
N10G0Z1  
N11G50; CANCEL SCALING
```

The values for X, Y, and Z in line 5 represent the absolute position of the scaling center. The I, J, and K values represent the scale factors for the X, Y, and Z axes respectively. When scaling each axis individually, you do not use a P code.

In this example, different scaling factors for the X and Y axes produce a shape similar to the one shown here.



When an arc is scaled differently in the two plane axes (X and Y in G17), an ellipse results. Because the Control Program cannot construct ellipses, it interprets the shape as an arc followed by a line segment move to the desired end point. The Control Program determines the arc by using the smaller of the two scale factors to determine its radius.

## Creating Mirror Images with Scaling

You can create mirror images of shapes by specifying negative values for I, J, and K. The NC program below uses negative I and J values to create a mirror image of the original shape on the XY plane (the scaling codes are in italics):

```
N0G0Z.5
N1X1Y1.5
N2G1Z-.1F10
N3G2Y.5J-.5
N4G0Z1
N5G51X1Y1Z0I-1J-1K1; SCALING ON
N6G0Z.5
N7X1Y1.5
N8G1Z-.1F10
N9G2Y.5J-.5
N10G0Z1
N11G50; CANCEL SCALING
```

---

### CAUTION!

---

Performing Z axis mirroring is an advanced operation. Use extreme caution when machining negative Z values.

Note: If you do not specify a scale factor for an axis, the value of that axis defaults to a factor of 1

The values for X, Y, and Z in line 5 represent the absolute position of the scaling center. The I, J, and K values represent the scale factors for the X, Y, and Z axes respectively. Notice the negative I and J values for mirroring on the XY plane. Remember that performing Z axis mirroring is an advanced operation. Use caution when machining negative Z values.

In this example, negative I and J values create a mirror image of the original shape, forming a complete circle.

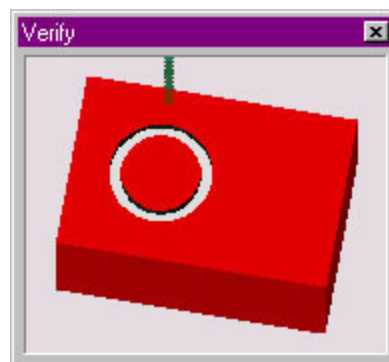



## Rotation Codes

Rotation codes allow you to rotate a programmed shape around a rotation origin. You can rotate a shape on any plane, one plane at a time. Use the Rotation code to modify an NC program when a work piece has been rotated from the programmed position on the machine.

**G68** Invokes rotation

**G69** Cancels rotation

Here is an example of an NC program using Rotation (the Rotation codes are in italics):

N0G0Z.5

N1X1Y1.5

N2G1Z-.1F10

N3G2Y.5J-.5

N4G0Z1

*N5G68X1.583Y1.5R90; ROTATION ON ROTATION ORIGIN XY*

N6G0Z.5

N7X1Y1.5

N8G1Z-.1F10

N9G2Y.5J-.5

N10G0Z1

*N11G69; CANCEL ROTATION*

In this example, G68 rotates a shape 90° from the original.

Rotation Origin  
(1.583, 1.5)

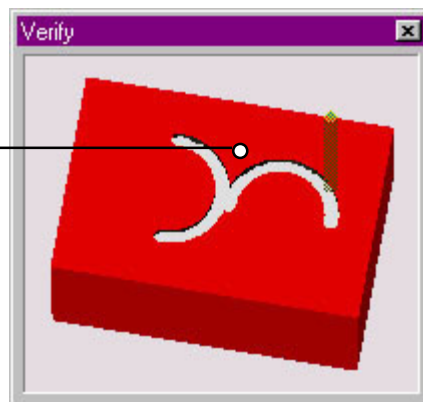

The X and Y values in line N5 are the coordinates of the rotation origin; the rotation occurs around this point. The R value represents the absolute value of the rotation angle. The G69 in line N11 cancels the rotation.

Note that positive R values represent counterclockwise rotation angles; negative R values represent clockwise rotation angles.

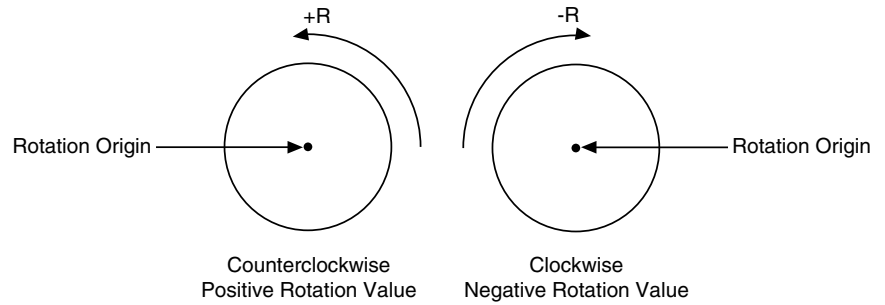

---

## IMPORTANT!

---

When combining the scale and rotate features, always scale the part first, before rotating it.

Notice that in this program the P Code is used to reference the first block of the subprogram (not shown in this example). The subprogram contains the code that creates each part.

In this example, scaling and rotation are combined to produce different sized shapes that are scaled and rotated from the original.

## Combining Scaling and Rotation Codes

You can combine scaling and rotation in the same NC program. The portion of the NC program below combines the scaling and rotation codes necessary to machine the following part (the actual subprogram to cut the shield (O100) is not listed here).

```
N1; DO THE ORIGINAL FIRST
N2M98P100
N3; NOW SCALE BY 1/2 AND ROTATE 90 CCW
N4G51X1.583Y0Z0I.5J.5K1; SCALING ON
N5G68X1.583Y1.5R90; ROTATION ON
N6M98P100; SECOND PART
N7; NOW MIRROR AND SCALE BY 1/2, AND ROTATE 90 CCW
N8G69G50
N9G51X1.583Y0Z0I-.5J.5K1
N10G68X1.583Y1.5R90
N11M98P100; THIRD PART
N12; NOW SCALE BY 1/2 AND ROTATE BY 90 CW
N13G69G50
N14G51X1.583Y0Z0I.5J.5K1
N15G68X1.583Y1.5R-90
N16M98P100; FOURTH PART
N17;END OF PROGRAM
```



---

## Multiple Tool Programming

The VMC-4000 allows you to define up to 20 different tools for use during milling operations. If your machine is equipped with an optional Automatic Tool Changer (ATC), multiple tool programs require very little user intervention, other than setup.

You will need to define tools, configure the ATC, and write the tool changes into the NC program. For defining tools and ATC configuration, the easiest method is to use the Setup Tool Wizard under the Tools menu. This will walk the user through all the setup steps.

Even if your machine is not equipped with the ATC, you may use the Wizard. Defining tools is explained in the tutorial on page D-8 of this guide. Programming codes, reference tools, offsets, and testing are described below.

---

## Using Multiple Tool Codes

The T code is used in the NC program to offset the cutter so that the NC program becomes independent of the cutter length, which is set up in the Setup Tool Library dialog box. This means you can replace a worn tool with a tool of a different length without changing the NC program, just by entering new offsets. (Any actual tool change is performed manually.) The T code can be located anywhere within the block of NC code, but it is normally placed after the G code.

When you place T codes in your program for tool changes, you should also use the M06 code to retract and shut off the spindle. This code instructs the machining center to shut off and retract the spindle to the top of the vertical column, where it pauses until you manually change the tool. Pressing the Enter key turns the spindle back on and moves it back to the previous position to continue with the NC program.

---

## Establishing the Reference Tool

When using multiple tools, a reference tool, normally Tool #1, is set to zero for the Z axis. This establishes a reference tool position which is used as a reference point for additional tools. For demonstration purposes, we will use Tool #1 as the reference tool and Tool #2 as the additional tool.

To set the reference tool:

1. Decide on a reference point (a point on the workpiece, or on a gauge, where you will jog the tip of each tool).
2. Install a tool into the spindle.
3. From the Tools Menu, choose Select Tool. If the tool is not already defined in the pull down menu, see page D-8 to define the tool.
4. Choose the tool you are using, then click the Select Tool button.
5. If you are using a Tool Height Sensor (included in the Quick Change tooling package), place it on the cross slide or other conductive surface.
6. Using the Jog Control Panel, jog tool #1 to the tip of the sensor until the lights come on.
7. Select **Set Position** from the Setup Menu, set the Z axis value to zero, and click OK.

Tool #1 is now established as the reference tool.

---

## Establishing Tool Offsets

Now that the reference tool is established, additional tools can be assigned offsets. You can move the tool and accept its current Z axis position as the offset value, or you can manually enter offset values.

To set the offset for Tool #2:

1. Install tool #2 in the spindle.
2. From the Tools Menu, choose Select Tool. If the tool is not already defined in the pull down menu, see page D-8 to define the tool.
3. Choose the tool you are using, then click Select Tool.
4. Jog tool #2 to the tip of the sensor until the lights come on.
5. Select **Offsets** from the Setup Menu.

---

### CAUTION

---

Do not use collets for tool changing. Use the Quick Change Tooling option to make sure the tool length protruding from the spindle does not vary each time you load a tool into the spindle.

6. Choose the correct tool (the description that matches the tool you installed) from the list, and click on the **Current Z** button at the bottom of the window. Select **OK** to save the value.
7. Repeat this process for each additional tool.

The offset for Tool #2 is now established.

---

## Testing Your Multiple Tool Program

After setting all of the tool offsets, test run your program without a workpiece mounted and with the spindle speed turned down.

1. After installing Tool #1, close the safety shield, put on your safety glasses, and complete the safety checklist.
2. Select the Run/Continue command from the Program Menu. Enter zero as the start block and select the Run Program button. Throughout the test, be prepared to press the emergency stop switch on the machining center, or the space bar on the computer keyboard in case of a tool crash. The computer will run the program until it reaches the M06 code. If your machine is equipped with an ATC, the tool change will take place automatically, and you may ignore steps 3-7. The M06 code stops the NC program and retracts the spindle.
3. When the spindle has completely stopped and the Pause message appears on the screen, push in the Emergency Stop button on the front panel.
4. Open the safety shield.
5. Remove Tool #1 and install Tool #2, making certain it is securely fastened to the spindle.
6. Close the door, and pull out the Emergency Stop button. Press the Enter key on the computer keyboard. The spindle turns on and moves to the previous position. Operation continues as programmed until the next M06 code is encountered.
7. At each pause, repeat Steps 3 through 6, installing the appropriate tool at the appropriate points in the program.
8. Edit the program, if required. When you are satisfied that the program works correctly, mount the workpiece, set the spindle speed, and run your multiple tool program.

# Understanding Coordinate Systems

For a beginning user, understanding coordinate systems can be difficult. The first thing to remember is before performing most machining operations, you are required to set the machine to “home” position. This returns the machine to the machine zero point, and acts as a reference point for all operations. It is a good idea to home the machine at power on.

## Machine Coordinates

Machine Zero is the extreme positive end of travel on the X,Y and Z. This is a fixed point on the machine, and cannot be changed. The machine uses this as a starting point for all operations. If the machine is not homed (set to the machine zero) it cannot coordinate the position of the Automatic Tool Changer, or accurately locate the workpiece on the cross slide. The machine is homed by selecting Set/Check Home under the Setup Menu, and choosing the Set Home button; or by using a G28 code in the NC program.

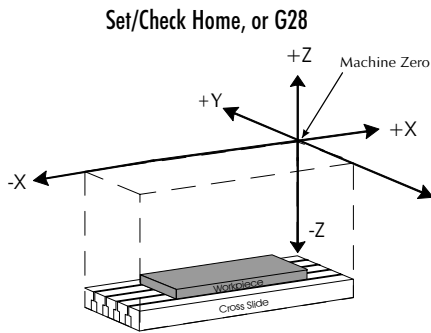

## Work Coordinates

Once home is set, your program will need a point of origin to start from. Setting a point of origin will establish the work coordinates. Work coordinates relate to the workpiece, and are usually set from the top of the front left corner of the workpiece mounted on the cross slide. Once the stock is mounted on the cross slide, jog the spindle to the top of the front left corner of the workpiece. From the Setup Menu, select Set Position. The spindle coordinates appear in the dialog box. Click on **OK** to set the current tool position as the point of origin on the workpiece.

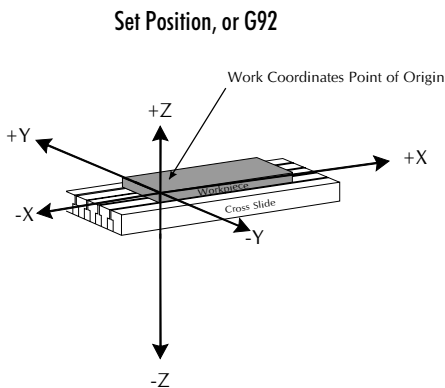

## Setting Coordinate Systems

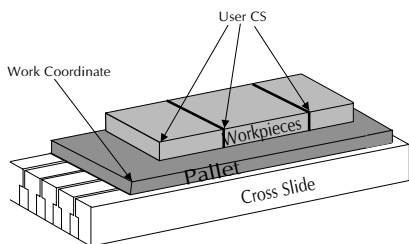

## Multiple Coordinate Systems

For more advanced operations, such as machining multiple parts, you can set up multiple coordinate systems. For example, three or four workpieces are attached to a pallet, and the pallet is secured to the cross slide. Set the work coordinate point of origin (0,0) at the corner of the pallet using the Set Position dialog box from the Setup Menu. After setting the corner of the pallet as the origin, select Coordinate Systems from the Setup menu. The Setup Coordinate Systems dialog box appears. Select a “User CS”, enter the coordinates for the first workpiece, and click on **Apply**. Repeat this procedure for as many User CS’ as necessary. (For a detailed description of the Setup Coordinate Systems procedure, see page E-44.)

## Using Tool Length Offset Codes

Setting tool length offsets is explained in Establishing Tool Offsets on page H-25. When you command a tool change in the program and the tool is loaded, the offset is automatically read as part of the tool information that was entered when the tool was defined.

However, if you are programming in Fanuc mode, that information is not recognized. Use the tool length offset codes to adjust the machine for variations in tool lengths. The tool length offset codes are:

- G43** Compensate for a longer tool.
- G44** Compensate for a shorter tool.
- G49** Cancel tool length offset.
- H** Specifies the offset number from the offset table. (The Offset Table you use for Tool Length Offset H values is the same table you use for Cutter Compensation and Tool Offset Adjust D values.)

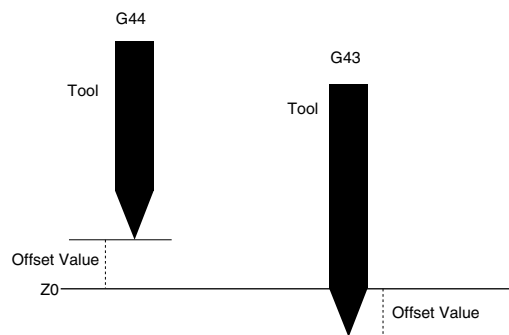

The G43 compensates for a longer tool by retracting the spindle away from the cross slide. The G44 compensates for a shorter tool by moving the spindle closer to the cross slide.

The T code normally specifies the tool, its diameter, and offset value. When you include a G43 or G44, the computer ignores the T code offset value and uses the offset you assign to H.

Here is an example of the tool length offset code used in an NC program:

```
M06  
G43T2H1
```

The M06 code stops the machine. The G43 compensates for a tool that is longer than the reference tool. The T2 refers to the tool number and the tool diameter, but not the offset value. The H1 represents the offset value set in the Offset Table.



## Using Tool Offset Adjust Codes

Use these codes for making critical dimension adjustments to the offset values. When you specify tool offset adjust codes, you can increase or decrease the movement distance of the specified axis by the offset value (D). The tool offset adjust codes are:

Longer tools need G43 to retract the spindle from the cross slide, while shorter tools need G44 to move the spindle closer to the cross slide.

- G45 Increases the movement amount by the value stored in the offset table
- G46 Decreases the movement amount by the value stored in the offset table
- G47 Increases the movement amount by twice the value stored in the offset table
- G48 Decreases the movement amount by twice the value stored in the offset table
- D Offset value

You must command a motion for tool offset adjust codes to adjust the offset values. Following are examples of the motions caused by tool offset adjust codes.

### Using G45

1. The offset value increases the actual movement by 1.5 beyond the commanded movement.



2. The negative offset value decreases the actual movement by 1.5 from the commanded movement. Note that A G45 code with a negative offset value is the same as a G46 code with a positive value.



## Using G46

The G46 code decreases the commanded movement by the offset value. Note that the G46 code is the same as reversing the positive or negative direction specified by the offset value of a G45 code.



## Using G47

The G47 code increases the commanded movement by twice the offset value.

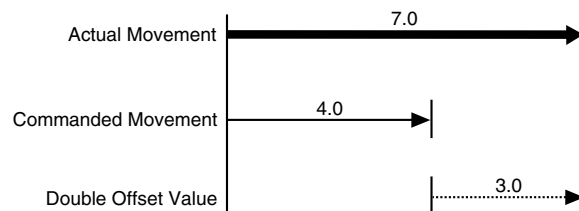

## Using G48

The G48 code decreases the commanded movement by twice the offset value. Note that the G46 code is the same as reversing the positive or negative direction specified by the offset value of a G47 code.

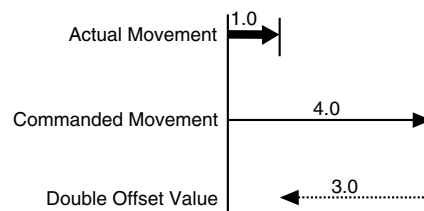

# General Machining Information

Feed Rate and Depth of Cut

Spindle Speeds

Feed Rate and Spindle Speed Selection

Tool Types

Sharpening Tools

## Feed Rate and Depth of Cut

Two terms used in general machining are *feed* and *cut*.

Normal machining on the machining center involves removing material from the surface of the workpiece. This is accomplished by advancing the cutting tool into the workpiece by an appropriate amount (depth of cut).

The rate of tool travel is called the feed rate, and is controlled by the X and Y axis drive motors. The depth of cut is set by the vertical column (Z axis) drive motor. The depth of cut and feed rate you select should depend on the turning speed of the spindle, the type of material and lubricant used, and the type of cutting tool used for the operation.

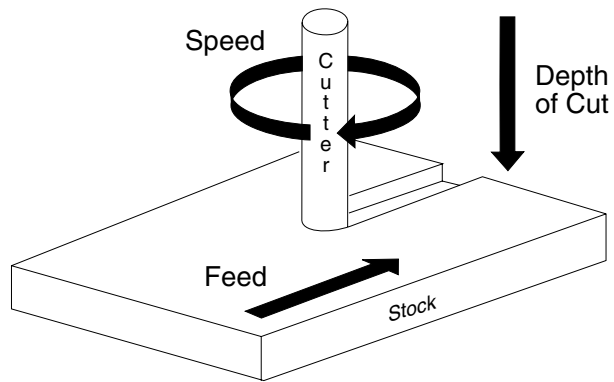

Excessive depth of cut and high feed rates place greater strain on the spindle, may bind the tool and workpiece, or produce a poor surface finish on the part.

---

## Spindle Speeds

The relative hardness of the material and the type of cutting tool (end mill or drill) affect spindle speed. The harder the material is, the slower the speed should be.

High spindle speeds may produce excess heat which causes the workpiece to expand. If the workpiece expands, the cutting tool will *rub* rather than cut the material, resulting in a poor surface finish. Slow spindle speeds cause no harm, but may be inappropriate for finishing certain types of materials.

The load put on the spindle motor must also be taken into account. Heavy cuts at low speeds will make the motor run hotter than lighter cuts at higher speeds. The selected feed rate and depth of cut should not cause the spindle motor to greatly lose speed or cause the tool to *chatter* against the workpiece.

---

## Feed Rate and Spindle Speed Selection

Feed rate selection for machining parts on the VMC-4000 depends on factors such as: type of material, type of cut, depth of cut, and spindle speed. The type of tool chosen to make the cuts also affects the depth of cut and, therefore, the feed rate. Consult your Machinist's Handbook for selecting a feed rate based on spindle speed and material type. Experience and experimentation will enable you to establish feed rates best suited to particular applications.

---

## Tool Types

Cutting tools are usually made from hardened steel and are ground to various shapes. The clearances ground behind cutting edges are adjusted for the type of material the tool will cut and the direction the tool will be fed along the workpiece.

Insufficient clearance behind the cutting edge will cause the tool to rub. Excessive clearance will produce a ridged or wavy finish due to the small length of tool edge in contact with the workpiece. Standard tool types are: end mills, center drills, drills and boring tools. Tools are often ground to shape by the operator to suit a particular cutting requirement.

### End Mills

End mills come in many shapes and configurations. They should be sharp and must run true. Holding end mills in a drill chuck is a poor practice; use collets instead. Be certain the spindle speed is set correctly for the type of material being machined. An end mill can be instantly damaged if a cut is attempted at excessive speed.

When plunging into the workpiece, use a center cutting end mill. Center cutting end mills have teeth at the end of the mill going into the center of the mill.

Begin with light cuts and progressively increase cuts until satisfactory results are obtained. End mills should not be used for drilling holes, but they can be used to enlarge holes.

---

#### CAUTION

---

Always be careful when handling end mills. They have sharp edges which can easily cut your hands. Use proper hand protection when handling tool bits.

## **Drills and Center Drills**

Drills and center drills are used to drill holes in a workpiece. Center drills have a tip that starts the hole before the actual drilling takes place. The workpiece is mounted in a vise or on the cross slide.

Use small amounts of cutting lubricant with center drills. Clear the drill frequently, otherwise the tip may clog and twist off even in soft materials.

## **Boring Tools**

Boring tools are used to enlarge or modify a drilled or cored hole in a workpiece. The workpiece is mounted in a vise or on the cross slide. Clearance must be maintained behind the cutting point of the tool.

A slow feed rate and frequent tool withdrawals are required with boring tools because chips cannot freely escape from the hole. Depth of cut and feed rates must be reduced to avoid chatter.

The tool should not be driven deeply into a hole. When boring a hole where a flat bottom is required, stop the down feed at least 0.002 inch above the desired depth of the smaller hole being bored out.





# Safe Machining Center Operation

**Safety Rules**

**Safety Checklist**

**Lista de Seguridad**

**Emergency Stops**

Feel free to copy these rules, or the Safety Checklist, and post them in your work area for quick reference.

---

## Safety Rules

The following safety rules should be reviewed and practiced by all operators of the VMC-4000.

---

### Wear Safety Glasses

Foresight is better than no sight. During operation any power tool can throw foreign objects and harmful chemicals into your eyes. Always put on safety glasses or eye shields before starting up the machining center. Safety glasses or shields should provide full protection at the sides, as well as the front of the eyes.

---

### Know Your Machine Tool

Read this guide carefully before you use the machining center and keep it readily accessible for quick reference. Know the intended applications and limitations of the machining center as well as its hazards.

---

### Ground All Tools

The machining center has an AC power cord terminated by a three-prong plug. The power cord should be plugged into a three-hole, *grounded* receptacle. If a grounding adapter is used to accommodate a two-prong receptacle, the adapter wire *must* be attached to a known ground. *Never* remove the third prong from the plug on the AC power cord.

---

### Keep the Safety Shield in Place

The safety shield should remain in place whenever the spindle motor is on or the cross slide is moving.

---

## **Remove Adjusting Keys and Wrenches**

Make it a habit to check that keys and adjusting wrenches are removed from the machining center before turning on the machine.

---

## **Keep the Work Area Clean**

Cluttered work areas and bench tops invite accidents.

---

## **Avoid a Dangerous Environment**

Don't use the machining center in damp or wet locations. Never operate electrical equipment in the presence of volatile and flammable petroleum-based solvents and lubricants.

---

## **Keep Untrained Visitors Away from the Equipment**

Children, and visitors unfamiliar with the hazards of rotating machinery, should always be kept away from the work area.

---

## **Prevent Unauthorized Users from Operating the machining center**

Lock and remove the key from the machining center control panel when the system is not in use.

---

## **Do Not Force a Tool**

Select the feed rate and depth of cut best suited to the design, construction and purpose of the cutting tool. It is always better to take too light a cut than too heavy a cut.

---

## Use the Right Tool

Select the type of cutting tool best suited to the milling operation. Don't force a tool or attachment to do a job it wasn't designed to do.

---

## Dress Appropriately

Don't wear loose clothing or jewelry which can get caught in moving parts. Wear a hat or net, or tie your hair back to keep it away from moving parts.

---

## Secure the Workpiece

Be certain that you have firmly secured the workpiece and the cutting tool in the collet before turning on the spindle motor.

---

## Do Not Overreach

Keep your footing and balance at all times so you won't fall into or grab the moving machine.

---

## Maintain Cutting Tools In Top Condition

Keep cutting tools sharp and clean. Lubricate and clean machining center components on a regular basis.

---

## Disconnect Tools Before Servicing

Always use the emergency stop switch to disconnect power and disable the spindle motor before mounting or removing the workpiece, or changing tools. *Do not* rely solely on a programmed Pause command to disable machining center operation.

---

## **Avoid Accidental Starting**

Make sure the power switch on the machining center is off before plugging in the power cord.

---

## **Use Recommended Accessories**

To avoid stressing the machining center and creating a hazardous machining environment, use only those accessories designed for use with the VMC-4000 machining center, available through Light Machines Corporation.

---

## **Tighten All Holding, Locking and Driving Devices**

Tighten the collet. Do not over-tighten tool holding devices. Over-tightening may damage threads or warp parts, thereby reducing accuracy and effectiveness.

---

## **Keep Coolant Away from Electrical Components**

Do not allow coolant to splash into or near the computer.

---

## **Do Not Operate the Machine Under the Influence of Alcohol or Drugs**

Alcohol or drugs may impair your judgement and reaction time, which could contribute to an on-the-job accident.

---

## **Avoid Distractions While Running the Machine**

Use simple common sense and pay attention while operating any piece of machinery.

# Safety Checklist

---

## IMPORTANT!

---

Post copies of this checklist in the work area. Verify that all items are checked-off prior to each operation of the BENCHMAN.

### Before you enter the work area:

- Put on safety glasses.
- Tie back loose hair and clothing.
- Remove jewelry including rings, bracelets and wristwatches.

### Before machining a part:

- Make sure you have the correct tool for the job.
- Secure the tool properly.
- Make sure all tool positions have been properly initialized.
- Verify the NC program on the computer before machining.
- Remove all loose parts and pieces from the machine.
- Remove adjusting keys and wrenches from the machine.
- Close the safety shield.
- Only operate the machine after being properly trained in its use.
- Perform a dry run:
  - Set the spindle speed to lowest manual speed setting.
  - Make certain there is no workpiece in place.
  - Run the NC program to make sure all the moves make sense before running the program with a workpiece in place.
- After completing the dry run, properly secure the workpiece to the machine.
- Keep fluids away from all electrical connections, electronic or electrical devices, the computer and nearby electrical outlets.

### While machining a part:

- Do not touch moving or rotating parts.
- Press the Emergency Stop button before opening the safety shield.
- Only open the safety shield after the spindle has stopped rotating.
- Press the Emergency Stop button whenever changing tools or mounting or removing a workpiece.
- Pull the Emergency Stop button out only after closing the safety shield.
- Keep all unauthorized persons away from the work area.

---

## ¡IMPORTANTE!

---

Pegue copias en el área de trabajo.  
Verifique que todos los puntos estén  
checados antes de cada puesta en  
marcha de la máquina.

# Lista de Seguridad

## Antes de entrar en el área de trabajo:

- Use sus lentes de seguridad.
- Procure recogerse el cabello y no usar ropa floja.
- No use joyería como: anillos, pulseras y relojes.

## Antes de trabajar a máquina una pieza:

- Utilice la herramienta correcta para el trabajo. Asegurela de forma correcta en el husillo con una boquilla.
- Asegurese que la posición de la herramienta de corte ha sido inicializada correctamente.
- Remueva todas las partes sueltas y coloquelas lejos de la Fresadora. Limpie todos los residuos de la Fresadora después de cada corrida.
- Cierre la guarda de seguridad antes de ejecutar cualquier operación en la Fresadora.
- Corra los programas por primera vez con el motor del husillo apagado y sin pieza de trabajo. Asegurese que todos los movimientos sean correctos.
- Asegure la pieza de trabajo a la mesa. Quite las herramientas y llaves antes de cerrar la guarda de seguridad.
- Asegurese que todos los contactos de corriente A.C. estén aterrizados.
- Mantenga los líquidos refrigerantes lejos de la Caja de Control, Computadora y cualquier Suministro Eléctrico.

## Mientras trabaja a máquina una pieza:

- Nunca levante la guarda de seguridad mientras que la Computadora este ejecutando un programa. Presione siempre primero el botón de “Paro de Emergencia”.
- Presione siempre el botón de “Paro de Emergencia” cuando se cambie una herramienta, se coloque o remueva una pieza de trabajo. Jale el botón de “Paro de Emergencia” después de haber puesto la guarda de seguridad.
- Mantenga fuera del área de trabajo a toda persona no autorizada.

---

## Emergency Stops

All BENCHMAN operators must be fully aware of how to shut down the machine quickly, should the need arise.

- ◆ In an emergency, you should **always** use the red Emergency Stop button on the machine front panel.
- ◆ You can also stop the machine by pressing the Control and Space keys on the computer keyboard, or by clicking on the stop buttons on the screen with the mouse. But, in an emergency, **always** use the Emergency Stop button on the machine.



# G and M Codes Listed by Group

**G Codes by Group**

**M Codes by Group**

## G Codes by Group

|                               |             |                                                                                                                                                                                                                                                                                                                                                                                                                                                                            |
|-------------------------------|-------------|----------------------------------------------------------------------------------------------------------------------------------------------------------------------------------------------------------------------------------------------------------------------------------------------------------------------------------------------------------------------------------------------------------------------------------------------------------------------------|
| <b>Interpolation Group</b>    | <b>G00</b>  | Rapid traverse                                                                                                                                                                                                                                                                                                                                                                                                                                                             |
|                               | <b>G01</b>  | Linear interpolation                                                                                                                                                                                                                                                                                                                                                                                                                                                       |
|                               | <b>G02</b>  | Circular interpolation (clockwise)                                                                                                                                                                                                                                                                                                                                                                                                                                         |
|                               | <b>G03</b>  | Circular interpolation (counterclockwise)                                                                                                                                                                                                                                                                                                                                                                                                                                  |
| <b>Programming Mode Group</b> | <b>G90</b>  | Absolute coordinate programming (Fanuc uses U,W): All X, Y and Z axes coordinates are relative to a (0,0) location on a mill.                                                                                                                                                                                                                                                                                                                                              |
|                               | <b>G91</b>  | Incremental coordinate programming: Each command is relative to the one before it in the program.                                                                                                                                                                                                                                                                                                                                                                          |
| <b>Units Group</b>            | <b>G70</b>  | Inch: Used to instruct the mill that inches are the unit of measure for the part program. (Fanuc G20)                                                                                                                                                                                                                                                                                                                                                                      |
|                               | <b>G71</b>  | Metric: Used to instruct the mill that millimeters are the unit of measure for the part program. (Fanuc G21)                                                                                                                                                                                                                                                                                                                                                               |
| <b>Wait Group</b>             | <b>G04</b>  | Dwell (wait): Equals the value of the feed rate (F code) in seconds (used primarily for robotic operations). G04 excludes motion commands with a new feed rate on the same line (block).                                                                                                                                                                                                                                                                                   |
|                               | <b>G05</b>  | Pause: Used for operator intervention. The order of action for the pause and dwell codes in one NC block is G05, G04 (pause, dwell).                                                                                                                                                                                                                                                                                                                                       |
|                               | <b>G25</b>  | Wait for robot input to be high: Used in conjunction with H code, which specifies input number. Used for robot synchronization.                                                                                                                                                                                                                                                                                                                                            |
|                               | <b>G26</b>  | Wait for robot input to be low: Used in conjunction with H code, which specifies input number. Used for robot synchronization.                                                                                                                                                                                                                                                                                                                                             |
|                               | <b>G31</b>  | Linear to specified coordinate. Stop short if specified input goes High (if H is positive) or Low (if H is negative).                                                                                                                                                                                                                                                                                                                                                      |
|                               | <b>G131</b> | Specifically for digitizing with the probe. The user specifies a Z position and a feedrate. The probe moves from its current position to the specified Z position at the specified feedrate (or current feedrate if not specified on the same block). If the probe input is tripped before reaching the specified Z position, a valid point is captured. In either event (point or not point), when the probe stops moving down, it rapids back to the initial Z position. |

**Polar Programming  
Group**

- G15 | Polar programming cancel.
- G16 | Begin polar programming.

**Coordinate System Group**

- G53 | Rapid traverse to specified coordinates in the Machine Coordinate System. (e.g. G53X0Y0Z0 rapids to machine reference point)
- G54 | Use coordinate system one.
- G55 | Use coordinate system two.
- G56 | Use coordinate system three.
- G57 | Use coordinate system four.
- G58 | Use coordinate system five.
- G59 | Use coordinate system six.

**Canned Cycle  
Group**

- G80 | Canned cycle cancel.
- G81 | Canned cycle drilling.
- G82 | Canned cycle straight drilling with dwell.
- G83 | Canned cycle peck drilling.
- G84 | Canned cycle tapping.
- G85 | Canned cycle boring.
- G86 | Canned cycle boring with spindle off (dwell optional).
- G89 | Canned cycle boring with dwell.

**Preset Position  
Group**

- G27 | Check reference point: This code moves the tool to its home position on the machining center to check the calibration of the axes. Compares reported position against zero to see if position has been lost.
- G28 | Set reference point: This code moves the tool to the home position on the machining center and calibrates the axes. This position is the Machine Coordinate System point of origin.
- G29 | Return to reference point: Moves the tool to a coordinate specified by XYZ. Typically used after a G27 or G28 code.
- G92 | Set position: This code works like the Set Position function under the Setup Menu (see Section 3). The X, Y and Z coordinates following a G92 code define the new current position of the tool.
- G98 | Rapid move to initial tool position after canned cycle complete (Section 5).
- G99 | Rapid move to point R (surface of material or other reference point) after canned cycle complete (Section 5).

|                                  |     |                                                                                                                                                                                                                                                                                     |
|----------------------------------|-----|-------------------------------------------------------------------------------------------------------------------------------------------------------------------------------------------------------------------------------------------------------------------------------------|
| <b>Plane Selection Group</b>     | G17 | Select the X,Y plane for circular interpolation. This is the default plane for circular interpolation. Use this code to switch back to the X,Y plane after circular moves on the X,Z or Y, Z planes. The arc center coordinates are given by I for the X axis and J for the Y axis. |
|                                  | G18 | Select the X,Z plane for circular interpolation. Use this code to perform circular interpolation on the X,Z plane. The arc center coordinates are given by I for the X axis and K for the Z axis.                                                                                   |
|                                  | G19 | Select the Y,Z plane for circular interpolation. Use this code to perform circular interpolation on the Y,Z plane. The arc center coordinates are given by J for the Y axis and K for the Z axis.                                                                                   |
| <b>Scaling Group</b>             | G50 | Cancel scaling.                                                                                                                                                                                                                                                                     |
|                                  | G51 | Invoke scaling. Use this code to scale axes with independent factors around a fixed origin. The default is 1.                                                                                                                                                                       |
| <b>Rotation Group</b>            | G68 | Invoke rotation. Use this code to rotate a geometry from its origin by an arbitrary angle. Rotation works on any plane, one plane at a time.                                                                                                                                        |
|                                  | G69 | Cancel rotation.                                                                                                                                                                                                                                                                    |
| <b>Cutter Compensation Group</b> | G39 | Corner offset in circular interpolation.                                                                                                                                                                                                                                            |
|                                  | G40 | Cancel cutter compensation.                                                                                                                                                                                                                                                         |
|                                  | G41 | Invoke cutter compensation left.                                                                                                                                                                                                                                                    |
|                                  | G42 | Invoke cutter compensation right.                                                                                                                                                                                                                                                   |
|                                  | D   | Specifies the offset number from the Offset Table.                                                                                                                                                                                                                                  |
| <b>Tool Length Offset Group</b>  | G43 | Shifts Z axis in a positive direction by a value specified by H.                                                                                                                                                                                                                    |
|                                  | G44 | Shifts Z axis in a negative direction by a value specified by H.                                                                                                                                                                                                                    |
|                                  | G49 | Cancel Tool Length Offsets.                                                                                                                                                                                                                                                         |
|                                  | H   | Specifies the offset number from the Offset Table.                                                                                                                                                                                                                                  |
| <b>Tool Length Adjust Group</b>  | G45 | Increases the movement amount by the value of D.                                                                                                                                                                                                                                    |
|                                  | G46 | Decreases the movement amount by the value of D.                                                                                                                                                                                                                                    |
|                                  | G47 | Increases the movement amount by twice the value of D.                                                                                                                                                                                                                              |
|                                  | G48 | Decreases the movement amount by twice the value of D.                                                                                                                                                                                                                              |
|                                  | D   | Specifies the offset number from the Offset Table.                                                                                                                                                                                                                                  |

## M Codes by Group

### Program Stop/End Group

|     |                                                                                                                                                                                                                                                                                                 |
|-----|-------------------------------------------------------------------------------------------------------------------------------------------------------------------------------------------------------------------------------------------------------------------------------------------------|
| M00 | <i>Pause:</i> Allows you to place a pause in your code. Acts like a G05 pause.                                                                                                                                                                                                                  |
| M01 | <i>Optional Stop:</i> Allows you to place an optional stop in your code. Place an M01 in the block of code where you would like to pause. With Optional Stop on, the M01 works like a G05. With Optional Stop off, the M01 code is ignored, the other codes on the block are executed as usual. |
| M02 | <i>End of Program:</i> Takes effect after all motion has stopped; turns off drive motors, spindle and accessory outlets.                                                                                                                                                                        |
| M30 | <i>Program stop:</i> Same as M02.                                                                                                                                                                                                                                                               |

### Spindle Group

|     |                                                                                                                                        |
|-----|----------------------------------------------------------------------------------------------------------------------------------------|
| M03 | <i>Spindle Motor On:</i> Activated concurrently with motion specified in the program block; remains in effect until superseded by M05. |
| M05 | <i>Spindle Motor Off:</i> Activated after the motion specified in the program block; remains in effect until superseded by M03.        |

### Tool Change Group

|     |                                                                                                           |
|-----|-----------------------------------------------------------------------------------------------------------|
| M06 | <i>Tool Change:</i> Used in conjunction with a T code to perform multiple tool operations. See Section F. |
|-----|-----------------------------------------------------------------------------------------------------------|

### Accessories On/Off Group

|     |                                                                                                                                                                     |
|-----|---------------------------------------------------------------------------------------------------------------------------------------------------------------------|
| M08 | <i>Coolant On:</i> Turns on coolant concurrently with the motion specified in the program block; remains in effect until superseded by M09.                         |
| M09 | <i>Coolant Off:</i> Turns off coolant; remains in effect until superseded by M08.                                                                                   |
| M10 | <i>Clamp ACC2:</i> Turns on ACC2. Closes air vise accessory concurrently with the motion specified in the program block; remains in effect until superseded by M11. |
| M11 | <i>Unclamp ACC2:</i> Turns off ACC2. Opens air vise accessory after the motion specified in the program block; remains in effect until superseded by M10.           |

M20

*Chain to Next Program:* This code appears at the end of a part program and is followed on the next line by the file name of another program which is executed when all motion stops. Here's an example of a part program chain to another program:

```
N37Z.2
N38M20
PROGRAM TWO
```

If the two programs you are chaining are not in the same directory, you must specify the full pathname for each file. If the specified file is not found, the Open dialog box appears so you can locate it.

M22

*Output to file:* Outputs information to a file. The first time the Control Program encounters an M22 code, it opens the specified file. You must enclose the name of the file in parentheses for the Control Program to recognize it.

The proper format for using this code is: M22([filename.ext [,A]]) [text and macros]. Items in brackets [ ] are optional, except that a filename is required for the first M22. If no text is specified to be output to the file, the current axis positions are output. M22 automatically adds a tilde (~) to the output text, so the next M22 starts on a new line in the file.

If you use more than one M22, only the first occurrence must have the filename in the parentheses. The remaining M22's may have empty parentheses, (). If you want to generate more than one file at a time you must include the filename each time you specify M22. If a filename is not specified, the first file opened is used.

Following is a list of special codes that can be used with M22 to generate run-time reports.

|           |                                                                       |
|-----------|-----------------------------------------------------------------------|
| @X        | Current X position (in current coordinate system)                     |
| @Y        | Current Y position (in current coordinate system)                     |
| @Z        | Current Z position (in current coordinate system)                     |
| ~ (tilde) | New line (starts a new line in the file)                              |
| @TD       | Time of day (12hour): "11:59:59AM"                                    |
| @TC       | Time (elapsed) for cycle: "99:11:59" (0's trimmed from left)          |
| @TT       | Time total (of program run): "99:11:59"                               |
| @TA       | Time Average (per cycle): "99:11:59" ("??:??" if first part)          |
| @TL       | Current tool number: "5"                                              |
| @C        | Cycle number (current pass): "3"                                      |
| @D        | Date: "12/31/94"                                                      |
| @FN       | Current file (without path): "PART.NC"<br>("UNTITLED.NC" if untitled) |
| \t        | Tab                                                                   |
| \\        | Outputs a single backslash character to the file                      |

The M22 code supports multiple output files. The first occurrence of a filename opens the file. In the name M22(FILE.OUT,A) TEXT... the output is appended to the file (if it exists). Each unique filename opens a separate file. For backward compatibility, empty parentheses M22() TEXT... cause the M22 output to go to the first file that was opened with an M22.

**Program Management Group  
-continued**

- |      |                                                                                                                                                                                                                                                                                     |
|------|-------------------------------------------------------------------------------------------------------------------------------------------------------------------------------------------------------------------------------------------------------------------------------------|
| M47  | <i>Rewind:</i> Restarts the currently running program; takes effect after all motion comes to a stop. Use the L code to repeat a finite number of times. The L code defines the number of times to run. For example, M47L2 rewinds twice.                                           |
| M98  | <i>Call to subprogram</i>                                                                                                                                                                                                                                                           |
| M99  | <i>Return from subprogram:</i> Returns you to the block following the initial M98 command.<br><br><i>Go to:</i> Used with P code. P code defines N code destination. Goes to first occurrence of N code within the main program. The N code can not follow any subprogram (O code). |
| M105 | This command is used to display messages in the Control Program.                                                                                                                                                                                                                    |
| M122 | Output current position to file. Almost identical to M22, except that if a macro (@X@Y@Z) is used to insert a coordinate, the position of the digitized point will be used, rather than the current machine position.                                                               |

**I/O Group**

- |     |                                                                                                                               |
|-----|-------------------------------------------------------------------------------------------------------------------------------|
| M25 | <i>Set device output:</i> Used for external device synchronization. Used in conjunction with H code to specify output number. |
| M26 | <i>Set device output:</i> Used for external device synchronization. Used in conjunction with H code to specify output number. |





# Index

## Symbols

10,000 RPM Spindle B-16  
4th Axis Control B-17

## A

About Benchman 4000 E-53  
Absolute coordinate programming code K-2  
AC Power Supply B-7  
Accessories J-5  
Address character F-2  
Adjust the Stock D-7  
Adjust the View D-6  
Adjustment B-11  
Administrator Mode E-50  
Air Vise B-16  
Alter existing tool E-32  
Arc Centers Incremental E-39  
Arrange Icons E-52  
Assign tool station E-33  
ATC Control Toolbar E-7  
Auto-refresh E-42  
Automatic Tool Changer B-17  
AutoSave E-49  
Axis Drive Belts B-13

## B

Backlash E-48  
Ball Screws  
    lubricant B-9  
Belts B-13  
Blocks  
    maximum number per program F-2  
    of NC code F-2  
Boring cycle G-11  
Boring cycle code G-7  
Boring cycle with dwell code G-7  
Boring cycle with spindle off code G-7  
Boring Tools I-5  
Buttons E-43

## C

Call to subprogram code G-13  
Canned cycle  
    boring G-11  
    cancel G-7  
    codes K-3  
    dwell G-9  
    G codes G-7  
    peck drilling G-9  
    programming G-7  
    straight drilling G-8  
    tapping threads G-10

Caring for Floppy Disks B-15  
Caring for the Computer B-14  
Cascade E-51  
Center Drills I-5  
Centerline Options E-42  
Chain to next program K-6  
Check Home E-43  
Check Your Shipment A-3  
circuit breakers B-4  
Circular interpolation G-4, H-14  
    clockwise, code for K-2  
    counterclockwise, code K-2  
Circular interpolation programming G-3  
Clamp ACC2 code K-5  
Clear E-19  
Close Command E-13  
compensation offset E-46  
Computer System Requirements A-2  
Configure ATC E-33  
Connecting Air A-18  
Connecting Power A-18  
Connecting the VMC-4000 A-16  
Connecting the VMC-4000 to the Computer A-18  
Context Help E-6  
Continue Program button E-3  
Control Program  
    screens C-4  
    starting C-2  
Coolant  
    filling B-18  
    Maintenance B-19  
Coolant Flow B-18  
Coolant Setup and Operation B-18  
Coordinate System  
    codes K-3  
    Command E-44  
Copy E-18  
Corner offset circular interpolation H-14  
Corner offset code K-4  
Crosspad E-9  
Ctrl+C E-58  
Ctrl+F E-58  
Ctrl+G E-58  
Ctrl+H E-58  
Ctrl+L E-58  
Ctrl+N E-58  
Ctrl+O E-58  
Ctrl+P E-58  
Ctrl+R E-58  
Ctrl+S E-58  
Ctrl+Shift+Z E-58  
Ctrl+Space E-58  
Ctrl+T E-58  
Ctrl+V E-58  
Ctrl+X E-58  
Ctrl+Y E-58  
Ctrl+Z E-58

- Customer Service Department A-4
- Cut E-18
- Cutter compensation H-6
  - canceling H-15
  - codes K-4
  - IJK vectors H-10
  - setting offsets H-11
  - starting H-6, H-7
- Cycle Start B-4, E-10
- Cycle Stop B-4

## D

- Default Values for Speed E-37
- Define the Tool D-8
- Delete E-19
- Depth of Cut
  - defined I-2
- Differences A-19
- Digitizing Package B-16
- DIP Switch Settings A-12
- docked screen component E-62
- DOW Corning 732 Silicone A-6
- Drive Power Light B-4
- Dry Run D-11
- Dwell code K-2

## E

- Edit Menu E-17
- Edit Tool Materials E-31
- Edit Window C-9
  - moving E-61
- Editor Preferences E-49
- Emergency Stop B-4, D-3
- Emergency Stop Button D-3
- Enable Soft Limits E-48
- Enable Subprograms E-39
- End Mills I-4
- End of program K-5
- Environmental Conditions B-8
- Estimate Runtime E-28, E-55
- Exit command E-16

## F

- F1 E-58
- F3 E-58
- F5 E-58
- F6 E-58
- F8 E-58
- Factory Installed Options B-16
- Feed Rate
  - defined I-2
- Feed Rate Override B-4, E-10
- Feedhold E-29
- File Default E-50
- File Menu E-12
- Find E-19

- floating screen component E-62
- Flood Coolant B-18

## G

- G92 E-45
- General Panel E-65
- Getting Ready for Installation A-3
- Glasses J-2
- Go to code K-7
- Goto Line E-20
- Goto Position E-44
- Graphite Dust Collection System B-17
- Grounding B-7

## H

- Hardware Installation A-7
- Helical interpolation G-5
- Help Index
  - Menu, Command E-52
- Home E-43
- Homing
  - commands H-3
- Hot Keys E-58

## I

- Inch programming code K-2
- Incremental coordinate programming code K-2
- Initial Tool Position E-42
- Initialize Station Location E-34
- Inputs Tool Bar C-8
- Inputs Toolbar E-7
- Insert N Codes E-21
- Insert or Remove Spaces E-22
- Insert Tool E-33
- Installation, software A-20
- Intended Use B-5
- Interface Card
  - Installing A-7
- interlock switch D-3
- Interpolation
  - circular G-3
  - linear G-2
- Interrupt Address
  - factory default A-10
  - Setting A-10

## J

- Jog Control E-25
- Jog Control Panel E-9
  - Pop-up Menu commands E-57
- Jog Distance E-37
- Jog Settings E-37
- Jog Speed E-37

## K

- Key Lock switch B-4

## L

- L code G-13
- Lifting Benchman A-5
- Limit Switches B-3
- limit switches D-3
- Linear
  - interpolation
  - programming G-2
- Linear interpolation code K-2
- Linear motion code K-2
- Lock E-23
- Loop counter code G-13
- Lubrication B-10

## M

- Machine Requirements A-2
- Machine Components B-3
- Machine Info Window E-4
- Main Power Light B-4
- Maximum blocks per program F-2
- Menu Bar C-4, E-12
- Message Bar E-3
- Metric code K-2
- Motion Control Card
  - Inserting A-8
  - Unpacking A-8
- Mount the Workpiece D-13
- Multiplier E-31

## N

- NC part programs F-2
- negative limit D-4
- New Command E-12
- Num Teeth E-31

## O

- O code G-13
- Offset
  - number E-46
  - number code K-4
  - sides, changing H-13
  - values, changing H-12
- Offset Table E-46, K-4
- Open Command E-13
- Opening a Recent Program E-16
- Opening the PC Chassis A-7
- Operate ATC E-34
- Operating Conditions B-7
- Operator Panel E-10, E-25
- Optional
  - Skip E-10, E-38
  - Stop E-10, E-39, K-5
- Options Panel E-42
- Origin E-41
- Output to file code K-6
- Outputs Toolbar C-6, E-8

## P

- P code, calling subprograms G-13
- Password
  - changing, creating E-51
- Paste E-18
- Pause E-29
  - G code for K-5
- Pause code K-2
- PC in a Shop Environment B-14
- Peck drilling code G-7
- Peck drilling cycles G-9
- Plane selection codes K-4
- Pneumatic Control B-17
- Polar programming H-2
- Polar programming cancel code K-3
- polar programming code K-3
- Pop-Up Menu E-54
- Position E-24
- Position Readout C-11
- Position Window E-5
  - Pop-up menu commands E-56
- Positioning Information Areas E-60
- Positioning Toolbars E-60
- positive limit D-4
- Power Switch B-4
- Preferences E-49
  - exiting E-50
  - Security E-50
- Preset View E-41
- preventative maintenance B-9
- Preview Window E-42
- Print E-15
- Print Setup E-15
- Program Edit Window E-3
  - Pop-up Menu commands E-54
- Program Menu E-26
- Program stop code K-5
- Programming
  - suggestions F-23
- proLIGHT 5000 Machining Center
  - misuses of B-6

## Q

- Quick Home E-43
- QuickRun E-55
- QuickVerify E-55

## R

- Rapid motion codes K-3
- Rapid to initial position code G-7
- Rapid to point R code G-7
- Rapid traverse
  - programming G-6
- Rapid traverse code K-2, K-3
- recommended coolant B-18

- Redraw E-57
- Register the VMC-4000 A-3
- Removal X Axis Cover A-6
- Remove Comments E-23
- Remove N Codes E-23
- Renumber E-21
- Renumbering and Subprograms E-22
- Replace E-20
- Reset Override E-47
- Restore Settings E-53
- Restore Unit Mode E-39
- Return from subprogram code G-13
- Return to reference point code K-3
- Rewind K-7
- robot synchronization codes K-2
- Rotation
  - and scaling H-23
  - codes for H-21
- Rotation codes K-4
- Rules, Safety J-1, J-2
- Run Settings E-27, E-38
- Run/Continue E-26, E-29
- Running a Sample NC Program D-5, D-13

**S**

- Saddle B-10
- Safety D-2
- Safety Glasses J-2
- Safety Rules D-2, J-1, J-2
- Safety Shield B-3, J-2
  - interlock switch D-3
- Save As ... E-14
- Save As Dialog Box E-14
- Save Command E-14
- Save Settings E-53
- Scaling
  - and rotation H-23
  - codes for H-18
  - creating mirror images with H-20
  - each axis H-19
- Scaling codes K-4
- select an existing coordinate system E-44
- Select Font E-24
- Select Tool E-32
- Selecting Commands
  - Pop-up Menus E-54
- Set
  - robot output K-7
- Set Position E-36
- Set reference point code K-3
- Set/Check Home E-43
- Setting
  - offsets H-11
  - soft limits H-4
- Setup Library E-30
- Setup Menu E-35
- Setup Program A-21, E-64
- Setup Tool D-8
- Sharpening Tools I-5
- Shield Interlock Switch B-3
- Shield, safety J-2
- Shift Z axis code K-4
- Show Tool E-42
- Simulation Mode E-63
- Single Step E-10, E-38
- slider bars E-42
- slider button E-42
- Soft Limits E-48
- Software Installation A-20
- Solid Options E-42
- Specify depth of cut code G-7
- Specify starting reference point code G-7
- spectraCAM B-2
- Spindle E-47
  - head B-12
  - motor off code K-5
  - motor on code K-5
- Spindle Motor B-3, B-12
- Spindle Shaft Play B-12
- Spindle Speed Override B-4, E-10
- spindle speeds B-2
- Standard Toolbar C-4, E-6
- Starting Block E-26
- Status Bar C-10, E-11
- Stock Dimensions E-41
- Stock Panel E-41
- Stop E-10, E-29
- Stop Program button E-3
- Stop Redraw E-57
- Stopping
  - with keyboard, with limit switch, with interlock s D-3
- Straight drilling G-8
- Straight drilling code G-7
- Straight drilling with dwell code G-7
- Style E-41
- Subprogram
  - call to K-7
- Subprogram reference block code G-13
- Subprogram, return from code K-7
- Subprograms G-13
  - nested G-13

**T**

- Tapping threads G-10
- Technical Support A-22
- Tile E-52
- Tip of the Day E-53
- Tool
  - add to library D-8
  - change code K-5
  - length offset H-28

- length offset code K-4
- offset adjust H-29
- Verify D-9
- Tool Library E-31
- Tool Type E-31, I-4
- Tool Wizard E-32
- Toolbars E-6, E-25
- Tools J-4
  - Creating E-31
- Tools and Fixtures B-5
- Tools Menu E-30

## U

- Unclamp air chuck code K-5
- Undo E-17
- Uniform scaling H-18
- Uninstalling the software A-21
- Units E-44
- Unpacking A-4
- Using Help E-53

## V

- Verify
  - While Running E-40
- Verify Program D-10
- Verify Settings D-6, E-27, E-40
- Verify Type E-43
- Verify Window C-12, E-4, E-25
  - Pop-up Menu commands E-56
- View Menu E-24
- View Panel E-41

## W

- Warnings as Errors E-39
- Warranty A-22
- Window List E-52
- Window Menu E-51
- Windows E-3
- Words, NC F-2
- Work Area B-7
- Workpiece Materials B-5
- Wrenches J-3

## Z

- Zero Position E-36
- Zoom E-41

