

SCORBASE

VERSION 7 AND HIGHER

FOR

SCORBOT-ER 4U

SCORBOT-ER 2U

ER-400 AGV MOBILE ROBOT

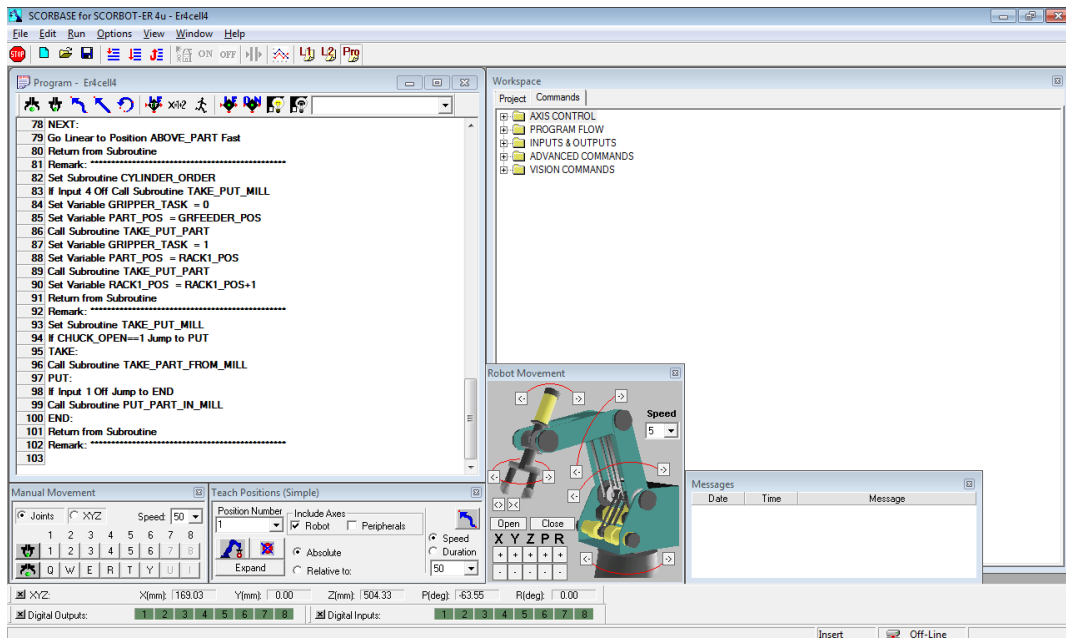

USER MANUAL

Catalog No. 100342 – Rev. 1

intelitek 



Copyright © 2016 Intelitek Inc.

Tel: (603) 625-8600

ScorBase User Manual

Fax: (603) 437-2137

Cat.# 100342 Rev. I

March 2016

website: <http://www.intelitek.com>

email: info@intelitek.com

All rights reserved. No part of this publication may be stored in a retrieval system, or reproduced in any way, including but not limited to photocopy, photography, magnetic or other recording, without the prior agreement and written permission of the publisher. Program listings may be entered, stored and executed in a computer system, but not reproduced for publication.

Every effort has been made to make this book as complete and accurate as possible. However, no warranty of suitability, purpose, or fitness is made or implied. Intelitek is not liable or responsible to any person or entity for loss or damage in connection with or stemming from the use of the software, hardware and/or the information contained in this publication.

Intelitek bears no responsibility for errors that may appear in this publication and retains the right to make changes to the software, hardware and manual without prior notice.



Table of Contents

1.	Introducing SCORBASE.....	1
2.	Starting SCORBASE.....	3
2.1.	System Requirements.....	3
2.2.	Installing the Software.....	3
2.3.	Uninstalling the Software	6
2.4.	Starting SCORBASE	6
2.5.	Quitting the Software.....	7
3.	Menus Overview	9
3.1.	The SCORBASE Window.....	9
3.2.	File Menu.....	10
3.3.	Edit Menu	12
3.4.	Run Menu	13
3.5.	Options Menu.....	14
3.6.	View Menu	16
3.7.	Window Menu.....	18
3.8.	Help Menu.....	19
3.9.	Charts	19
4.	Homing and Control.....	23
4.1.	General	23
4.2.	Homing	24
4.2.1.	Search Home All Axes Command	24
4.2.2.	Search Home – Robot Command	25
4.2.3.	Search Home – Peripherals Command	25
4.3.	Go Home Command	25
4.4.	On-Line Mode / Off-Line Mode	25
4.5.	Control On / Control Off – CON/COFF	25
5.	Position Definition	27
5.1.	Joint and Cartesian Coordinate Systems	27
5.1.1.	Joint Coordinate System.....	28
5.1.2.	Cartesian Coordinate System (XYZ)	28
5.2.	Absolute and Relative Positions	29
5.3.	Record and Teach	30
5.4.	Manual Movement Dialog Box.....	30
5.5.	Robot Movement Dialog Box.....	32

5.6.	Teach Positions Dialog Box	32
5.6.1.	Simple (Level 1)	32
5.6.2.	Simple (Advanced Level)	33
5.6.3.	Expand (Advanced and Pro Levels).....	34
5.6.4.	Simple (Pro Level).....	35
5.7.	Recording Positions (Joint Coordinates)	35
5.7.1.	Record Absolute Position (Levels 1, 2 & Pro).....	35
5.7.2.	Record Relative Position (Pro Level).....	36
5.8.	Teaching Positions (XYZ Coordinates)	36
5.8.1.	Teach Absolute XYZ Position (Levels 2 & Pro).....	36
5.8.2.	Teach Relative XYZ Position (Levels 2 & Pro).....	37
5.9.	Positions Window	37
5.9.1.	Overview	37
5.9.2.	Position Popup Window	38
5.9.3.	Watch Popup Window	39
5.10.	Position Data Dialog Bars	39
5.10.1.	Encoder Counts Dialog Bar.....	39
5.10.2.	XYZ Dialog Bar	40
5.10.3.	Joints Dialog Bar.....	40
5.11.	Using a Teach Pendant with SCORBASE	40
6.	Program Editing	41
6.1.	Opening and Closing a Program	41
6.2.	Program Editing Tools	42
6.3.	Adding and Editing Commands	44
6.4.	Axis Control Commands	45
6.5.	Program Flow Commands	55
6.6.	Input/Output Commands	66
6.7.	Advanced Commands.....	72
6.8.	Vision Commands.....	73
7.	Variable Programming	75
7.1.	Using a Variable Instead of a Numeric Value:	75
7.2.	Monitoring Variable Value	76
8.	Program Execution.....	79
8.1.	Running a Program	79
8.2.	Halting Program Execution	79
8.3.	Inputs and Outputs Dialog Bars	80



- 8.3.1. Digital Inputs & Outputs Dialog Bars80
- 8.3.2. Analog Inputs & Outputs Dialog Bars81
- 8.4. SCORBASE Log File..... 82
- 9. Project Files Management83
 - 9.1. Project Management 83
- 10. System Configuration.....85
 - 10.1. Window Layout Options 85
 - 10.1.1. Simulation & Teach86
 - 10.1.2. Teach & Edit.....87
 - 10.1.3. Run Screen88
 - 10.1.4. Project Screen89
 - 10.1.5. Open CIM Screen90
 - 10.1.6. User Screen; Save User Screen.....91
 - 10.2. Options Menu..... 91
 - 10.2.1. Hardware Setup92
 - 10.2.2. Parameter Set Window.....94
 - 10.2.3. Line Number95
 - 10.2.4. Reload Last Project at Startup.....96
 - 10.2.5. Experience Level96
 - 10.3. View Menu 97
 - 10.3.1. Dialog Bar Display Options98
- 11. Appendix: Command Line Options99

1. Introducing SCORBASE

SCORBASE for SCORBOT-ER 4u is a robotics control software package for robot programming and operation. SCORBASE for SCORBOT-ER 4u provides numerous features:

- Communication with the robot controller over USB channel
- Control and real-time status display of five robot axes, gripper and two peripheral axes
- Full support and real-time status display of eight digital inputs, eight digital outputs, four analog inputs, and two analog outputs
- Position definition and display as well as manual robot movement in reference to Joint Coordinate System (encoder units)
- The Cartesian Coordinate System (X,Y,Z, Pitch and Roll) is used.
- Robot movement definition as **Go to Position**, **Go Linear**, or **Go Circular**, with active speed settings in percentages (Availability depends on Experience Level setting.)
- Default setting of 1000 positions and 10000 active program lines
- Interrupt programming for handling responses to changes in digital input status
- Variable Programming, in three levels of complexity, to moderate the learning curve. This makes it possible for beginners to start at a lower level, and advance through the levels, as they become more skilled in robotics programming.
- Saving and loading projects
- SCORBASE can be installed as part of RoboCell, an interactive graphic software package, which provides simulation of the robot and other devices in the workcell

This manual describes all the features and operations for all Experience Levels of SCORBASE. When necessary, illustrations show the differences in the levels, and descriptions note the availability of options and commands.

2. Starting SCORBASE

The instructions in this chapter are for SCORBASE only.

If you intend to install SCORBASE as part of the RoboCell software package, follow the instructions in Chapter 2, Starting RoboCell, in the RoboCell User Manual.

2.1. SYSTEM REQUIREMENTS

For best performance, the following system is recommended:

- Intel Core i5 2400 GHz 2400 GHz or higher, equipped with CD drive
- At least 1GB RAM (4 GB for Windows 7 and higher)
- A hard drive with at least 200 MB of free disk space
- A mouse
- USB port
- Windows XP/7/8/8.1/10

Note: Your operating system might have additional hardware requirements.

2.2. INSTALLING THE SOFTWARE

The SCORBASE software is supplied on a CD which also contains RoboCell. Close any open applications before proceeding with the installation procedures. If you are about to reinstall the software, or install a newer version to an existing SCORBASE directory, it is recommended that you back up any existing user-created files before you begin the installation. It is also recommended that you remove the previous SCORBASE version for Windows installation, using the software's Uninstall utility.

To install SCORBASE:

1. Insert the CD into the CD-ROM drive to start the installation procedure.
 - If the procedure does not start, either:
 - From the Windows task bar, click **Start | Run** and type D:Setup (where D: is your CD drive),
or
 - Using Windows Explorer, explore the CD drive and click  Setup.

2. Wait until the Welcome window is displayed.

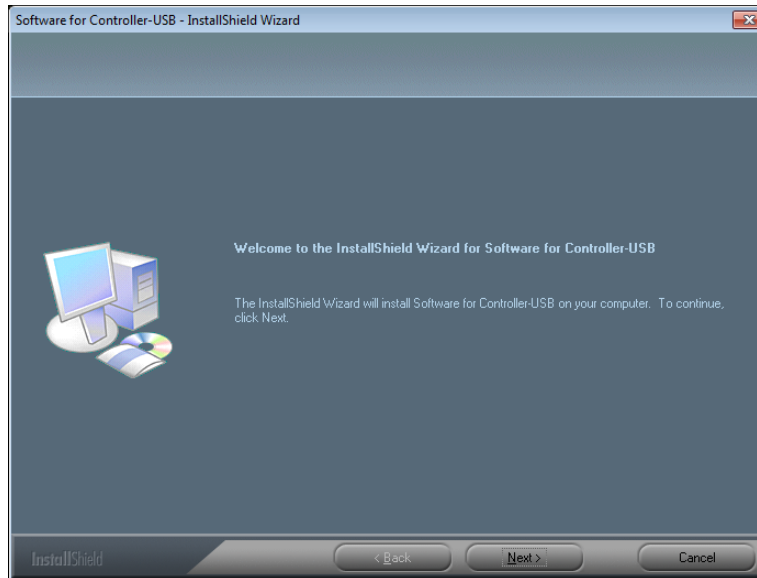

3. Click **Next**. The License Agreement window is displayed.



4. Review the Intelitek software license agreement. You must accept the terms of this agreement in order to proceed with the installation. To accept, choose **Yes**. The Software Selection Window is displayed.

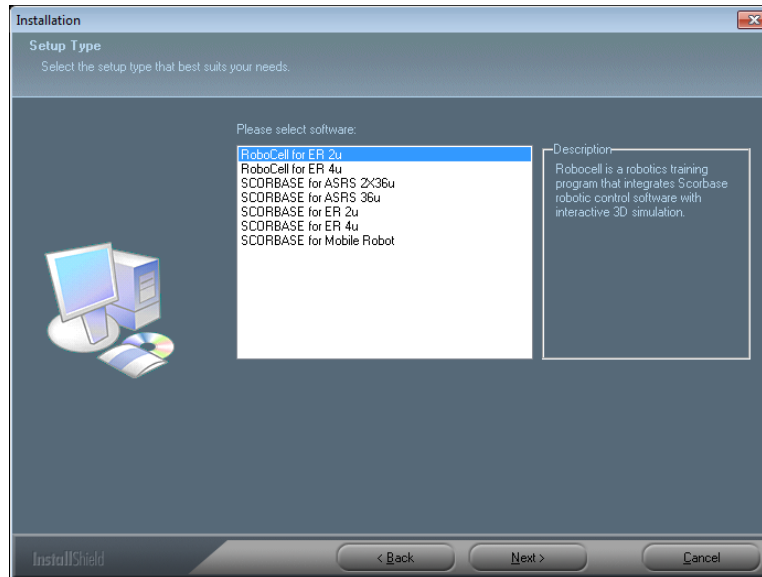

5. Select SCORBASE for ASRS 2X36u, SCORBASE for ASRS 36u, SCORBASE for ER 2u, SCORBASE for ER 4u or SCORBASE for Mobile Robot. The robot that you select becomes the default robot while you are working in SCORBASE, although you can choose to open a new project and work with a different robot. See the Hardware Setup option in the Options Menu. Click **Next**. The Setup Type window is displayed.

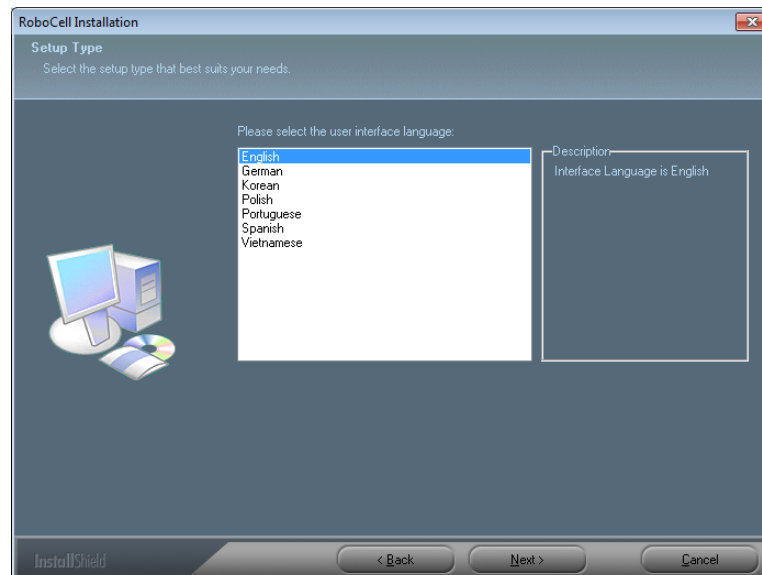

6. Select the desired language and click **Next**. The Choose Destination Location window is displayed.

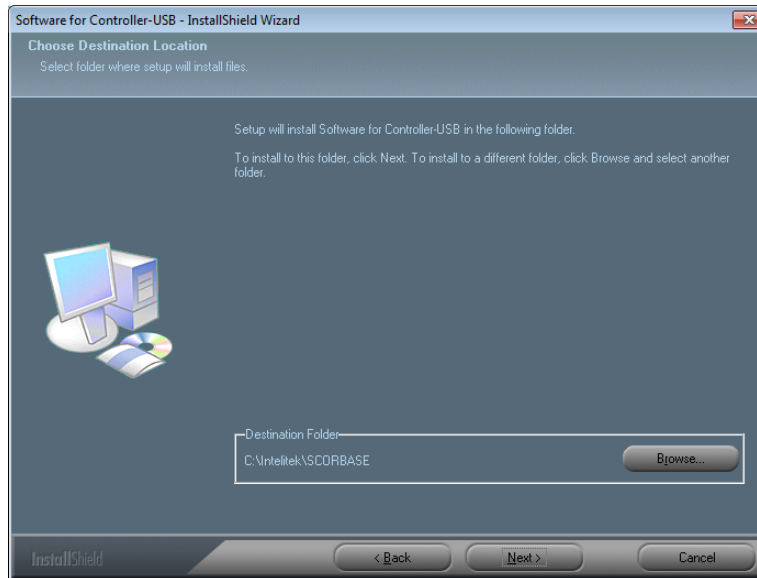

7. The default destination folder for the files is:
 \Intelitek\SCORBASE
 Click **Next** to accept the default, or click **Browse** to select another folder and then click **Next**. The Select Program Folder window is displayed.
8. Click **Next** to complete the installation procedure.

2.3. UNINSTALLING THE SOFTWARE

To uninstall SCORBASE:

1. In the SCORBASE program group, select **UnInstall**.
2. Follow the instructions that are displayed on the screen.

2.4. STARTING SCORBASE

To start SCORBASE:

1. Ensure that all the components to be used are installed and connected according to the installation procedures detailed in the User Manuals supplied with the robot and controller.
2. Turn on the computer and the controller.
3. Select **Start | Programs | SCORBASE**.

4. Select the **SCORBASE** command. After initialization, this screen is displayed:

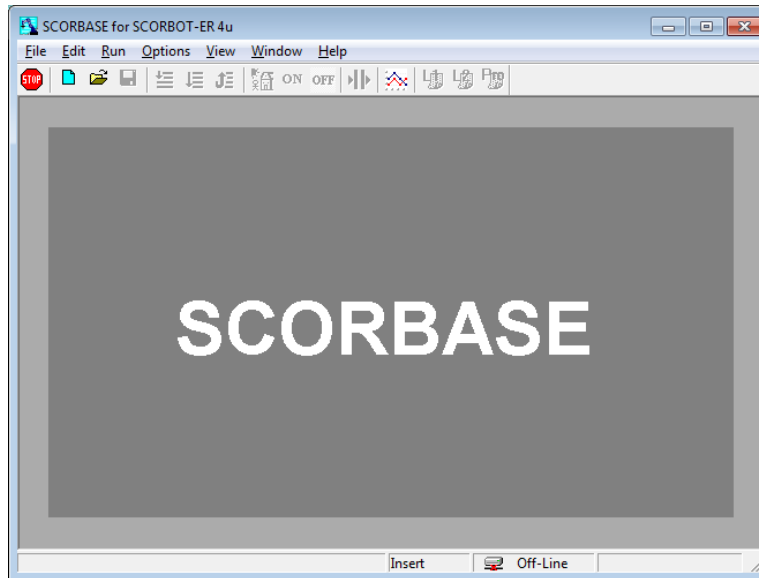

If SCORBASE opens in Off-Line mode or the controller is not detected, the program loads and operate in Off-Line mode.

Only one instance of SCORBASE can be active at a time.

2.5. QUITTING THE SOFTWARE

Stop the SCORBASE program (if running). If you have unsaved changes in the project, SCORBASE prompts you to save the changes before closing.

To close SCORBASE (or its components), do any of the following:

- From the Menu Bar, select **File | Exit**.
- Click the **Close** box in the SCORBASE Title Bar.
- Press **Alt + F4**.

3. Menus Overview

3.1. THE SCORBASE WINDOW

The image below shows the SCORBASE opening screen. The screen comprises:

- A Title Bar containing the screen name and the standard Windows controls for sizing and closing the application screen.
- A Menu Bar containing all SCORBASE command menus and options.
- A Toolbar containing icons for the most commonly used options.
- A Status Bar displaying information regarding the SCORBASE software, modes of operation, current activity, etc. When you position the mouse over an icon, a description of the icon is displayed in the status bar.

Note: The System menu (displayed by right clicking the Title Bar) contains the **Always on Top** menu item, enabling you to display the application on top at all times.

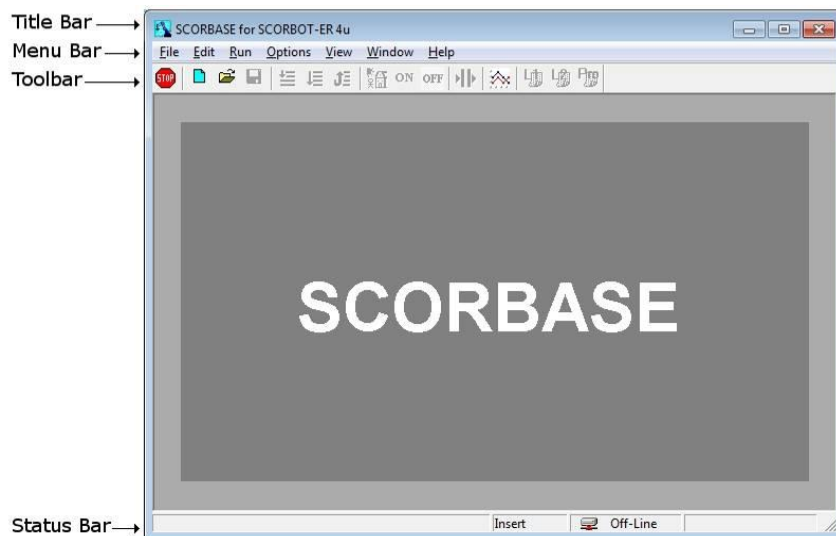



3.2. FILE MENU

A SCORBASE project contains a program (SBP file), user-defined positions (PNT file), and a project data file (WS file). If RoboCell is also being used, the project includes the cell image (3DC file). Throughout this manual, the term “project” refers to the program positions (and image) files saved by the user as one entity.

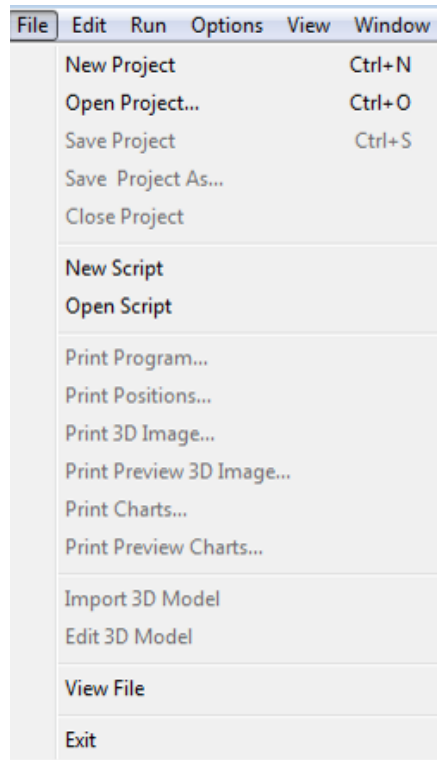
The File Menu is shown here:



The File menu contains the standard Windows functions that allow you to open new or previously saved projects, save and close projects. You can print files containing robot programs and positions, and you can exit the software.

File Menu Options		
Icon	Option (Shortcut)	Description
	New Project (Ctrl+N)	Opens a new untitled project
	Open Project (Ctrl+O)	Opens the Load Project window which lists SCORBASE files (without a virtual cell)
	Save Project (Ctrl+S)	Saves the currently active project (program, positions and graphics)
	Save Project As...	Saves the currently active project under a new project name

File Menu Options		
Icon	Option (Shortcut)	Description
	Close Project	Closes the currently open project
	New Script	Opens Notepad for writing a new Visual Basic script. Save the file with a .VBS extension in the same directory as the SCORBASE project file. The best practice for naming the file is: <SCORBASE project name>.VBS.
	Open Script	Opens the File Selector box for opening an existing Visual Basic script file
	Print Program	Prints the program. (The Program window must be active)
	Print Positions	Prints the user-defined positions. (Positions Window must be active)
	Print 3D Image	Reserved for the RoboCell program option
	Print Preview 3D Image	Reserved for the RoboCell program option
	Print Charts	Opens a dialog box to select the specific axis chart for display or printout. Only one axis can be selected at a time. See 3.9 Charts on page 19 for more information.
	Print Preview Charts	Displays the selected axis chart before printout
	Import 3D Model	Reserved for RoboCell program option
	Edit 3D Model	Reserved for RoboCell program option
	View File	<p>Enables you to view a file from those listed:</p> <ul style="list-style-type: none"> • SCORBASE programs (*.sbp) • Position data (*.pnt) <p>When you select a file, a window opens displaying that file. This is useful for copying lines from another existing SCORBASE program into a program being written.</p>
	Exit	Closes SCORBASE. If changes to a program or position file have been made but not yet saved, a message is displayed giving you the opportunity to save the file before you exit SCORBASE.

3.3. EDIT MENU

The Edit menu contains the standard Windows functions that allow you to edit program files.

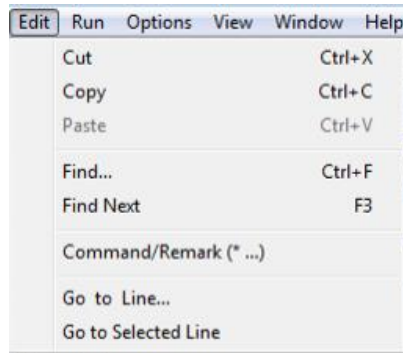

The Edit Menu options are summarized in this table.

Edit Menu Options	
Cut (Ctrl+X)	Deletes selected text or lines from the program lines, and places it on the Windows and SCORBASE clipboards
Copy (Ctrl+C)	Places a copy of selected text or lines from the program lines on the Windows and SCORBASE clipboards
Paste (Ctrl+V)	Inserts the contents of the SCORBASE clipboard into the program lines
Find (Ctrl+F)	Opens a dialog box that allows you to search for a particular text string, SCORBASE command, or command argument
Find Next (F3)	Repeats the last Find operation for the next occurrence
Command/Remark (* ...)	Inserts/deletes asterisk at beginning of a SCORBASE program command line. This action toggles the command line between a remark and an executable command.
Go to Line...	Opens a dialog box that displays the total number of lines in the program and prompts you for a line number. The program editor jumps to the line you specify.
Go to Selected Line	Display the line selected. This is useful for long programs.

3.4. RUN MENU



The Run menu contains SCORBASE commands for homing the robot and peripheral axes (see section 4 Homing and Control page 23), and executing programs.

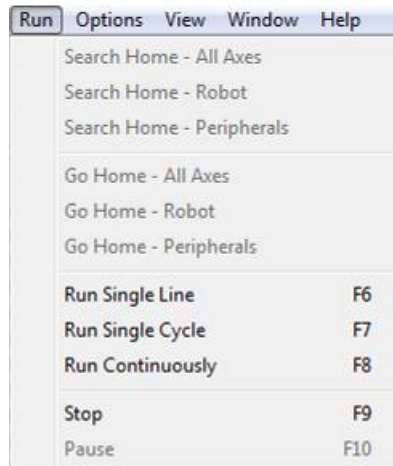



The Run Menu is shown here:



Note: If the software is operating Off-Line, only the Run program options are available in this menu.

This table summarizes the Run Menu options.

Run Menu Options		
Icon	Option (Shortcut)	Description
	Search home - all axes	Homes both the robot and any configured peripheral axes
	Search home – robot	Homes the robot This command is available only if the system has been homed once, after opening SCORBASE.
	Search home – peripherals	Homes the peripheral This command is available only if the system has been homed once, after opening SCORBASE.
	Go home – all axes	Sends the robot and peripherals to their home positions
	Go home - robot	Sends the robot to its home position. This command does not home the robot.
	Go home – peripherals	Sends the peripherals to their home position. This command does not home the peripherals.
	Run single line (F6)	Executes the selected (highlighted) program line. See 8 Program Execution on page 79 for more information.

	Run single cycle (F7)	Executes the program from the selected (highlighted) program line to the end of the program
	Run continuously (F8)	Executes the program from the selected (highlighted) program line. When the last program line is reached, the program starts again from the first line.
	Stop (F9)	Immediately stops program execution and movement of all axes
	Pause (F10)	Stops program execution after the current line is executed



Note: Pause and Stop are software methods for halting program execution. In an actual emergency situation, you should use the EMERGENCY button on the controller or the ABORT key on the Teach Pendant.



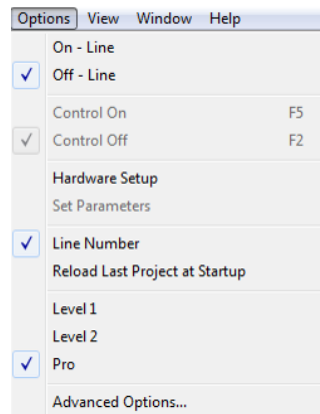

3.5. OPTIONS MENU

The Options menu allows you to define your preferences for operating the software.

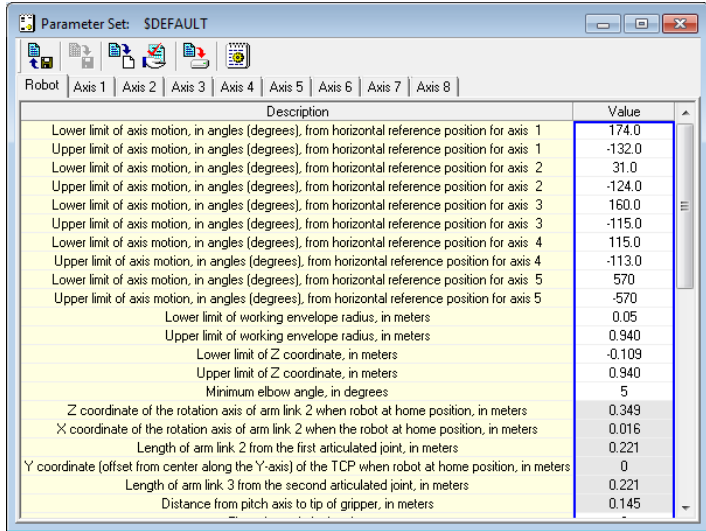

The features of the Options menu are summarized in this table:

Options Menu		
Icon	Option (Shortcut)	Description
	On-Line	Establishes communication with the controller
	Off-Line	SCORBASE does not communicate with the controller, even though it may be connected. Off-Line mode is useful for checking and debugging programs.
	Control On (F5)	Enables servo control of the axes
	Control Off	Disables servo control of the axes

Options Menu		
Icon	Option (Shortcut)	Description
	Hardware Setup	Opens the Hardware Setup dialog box where you can define the peripheral devices which are connected and operated by the controller as axes 7 and 8
	Set Parameters	<p>Opens the Parameter Set Window Advanced Commands must be activated in order to utilize Set Parameters.</p>  <p>Parameters can be set for the robot and for each one of the eight axes. Select the appropriate tab and set the desired parameters.</p>
	Line Number	Shows/hides program line numbers in the program window
	Reload Last Project at Startup	When checked, opens the last project saved when SCORBASE is started
	Level 1	Displays list of commands and options at introductory level. Commands related to Level 2 and Pro are disabled. See 10.2.5 Experience Level on page 96 for more information.
	Level 2	Displays list of commands and options at advanced level. Commands related to Pro are disabled.
	Pro	Displays list of all commands and options

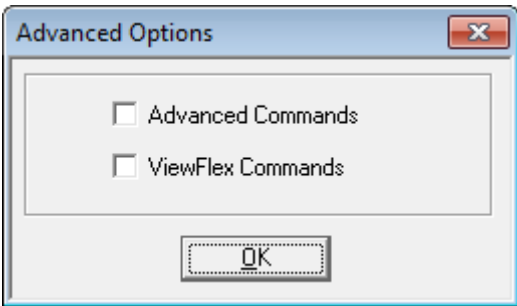
Options Menu		
Icon	Option (Shortcut)	Description
	Advanced Options	<p>Opens a dialog box in which these options are available:</p> <ul style="list-style-type: none"> • Advanced Commands • ViewFlex Commands (see the ViewFlex User Manual) <div data-bbox="711 499 1224 802" data-label="Image">  </div> <p>When one or both options are checked, the corresponding commands (Advanced Commands and Vision Commands) are listed under the Command tab of the Workspace Window. Parameters should only be modified by skilled operators.</p>

3.6. VIEW MENU

The options in the View menu allow you to show/hide SCORBASE dialog bars and windows.

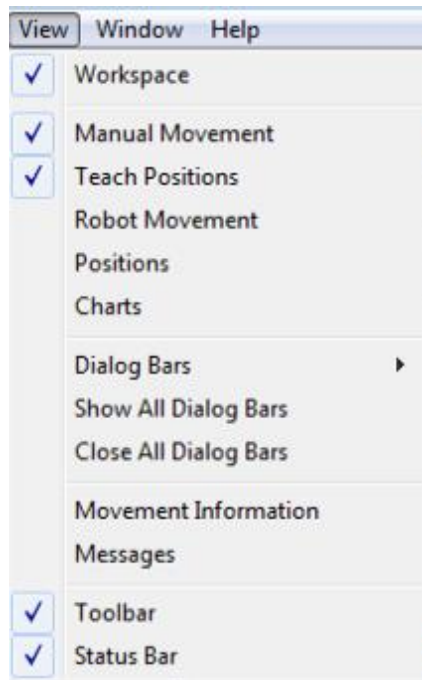

The View Menu options are described in this table:

View Menu Options	
Option	Description
Workspace	Shows/hides the Workspace Window. Through this window, the user can access the project files and the SCORBASE commands tree.
Manual Movement	Shows/hides the Manual Movement Dialog Box. This box enables manual control over the movements of the robot, the gripper and peripheral axes.
Teach Positions	Shows/hides the Teach Positions Dialog Box. This box enables recording, teaching and deleting positions. It also enables the user to send the robot and/or peripherals to a previously defined position. The functions available depend on the current Experience Level setting.
Robot Movements	Opens the Robot Movement Dialog Box. Pressing on a selected axis moves it in the selected direction.
Positions	The Positions Window displays the positions of the currently open project. The list is presented in tabular format.
Charts	Opens Charts
Dialog Bars	<p>Toggles the display of seven dialog bars that enable the following:</p> <ul style="list-style-type: none"> • Joints – Displays the robot’s joints angle (five joints). • XYZ - Displays the robot tool center point (TCP) position and orientation. The coordinate system origin is at the center of the robot base at table level. • Digital outputs - Displays the status of digital outputs 1-8 (dark green - off; light green - on). Click an output to show/hide its status. • Digital inputs - Displays the status of digital inputs 1-8 (dark green - off; light green - on). In Off-Line clicking on input toggles its status. • Analog outputs - Displays the value of analog output 1&2 (0-255)-(0-10 volt). • Analog inputs - Displays the value of analog input 1-4 (0-255). In Off-Line you may set the analog input value. • Encoders – Displays the encoder counts of axes 1-8. (Encoders are zeroed after homing the system.)
Show All Dialog Bars	Displays all seven dialog bars
Close All Dialog Bars	Closes all seven dialog bars
Movement Information	<p>Displays the following data:</p> <ul style="list-style-type: none"> • Position error of eight axes in encoder counts • Home switch status of all eight axes <p>PWM for one selected axis. The PWM (Pulse Width Modulation) is the controller output for the selected axis motor</p>

View Menu Options	
Option	Description
Messages	Opens the Messages Window The data displayed in the Messages window is printed using the PS (Print to Screen & Log) commanding SCORBASE.
Toolbar	Shows/hides the programming toolbar (default on)
Status Bar	Shows/hides the lower status bar (default on)

3.7. WINDOW MENU

The Window menu enables you to select the desired window layout options.

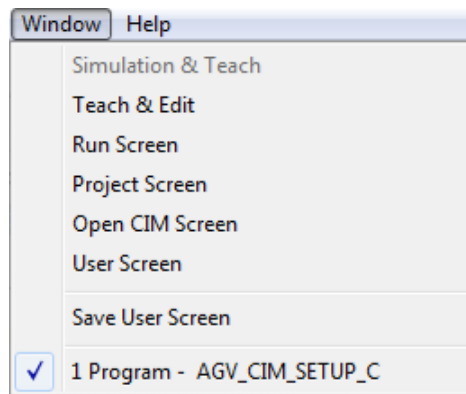

The Window Menu options are described in this table.

Window Menu Options	
Option	Description
Simulation & Teach	Sets the screen to display the RoboCell window and the dialog bars required to define positions. This is disabled in SCORBASE.
Teach & Edit	Opens the Program Window, Workspace Window, Manual Movement Window and Teach Position Window.
Run Screen	Displays the Program Window and its toolbar
Project Screen	Displays the Program Window and Positions Window
Open CIM Screen	Displays the Program Window, Open CIM Device Driver Window, and CIM Messages Window
User Screen	This allows the user to customize the screen layout according to personal preference
Save User Screen	This saves the User Screen layout, allowing it to be recalled with the User Screen command
[Project Name]	Displays the file name of the open project

3.8. HELP MENU

The Help menu is shown here:

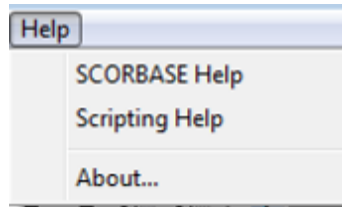

This table describes the Help menu options.

Help Menu Options	
Option	Description
SCORBASE Help (F1)	Opens SCORBASE On-Line help
Scripting Help	Opens help files for Visual Basic scripting
About	Shows the SCORBASE software version

3.9. CHARTS

SCORBASE charts can be configured to display the following data (Y-axis) vs. time (X-axis):

- Encoder counts (axis position), represent the actual axis position. The encoder counts are shown as a blue line.
- Position error is the difference between the required axis position and the actual axis position. The error is expressed in encoder counts and is shown as a red line.
- The PWM value represents the controller output. The error and the axis control parameters determine the PWM value which is shown as a green line.

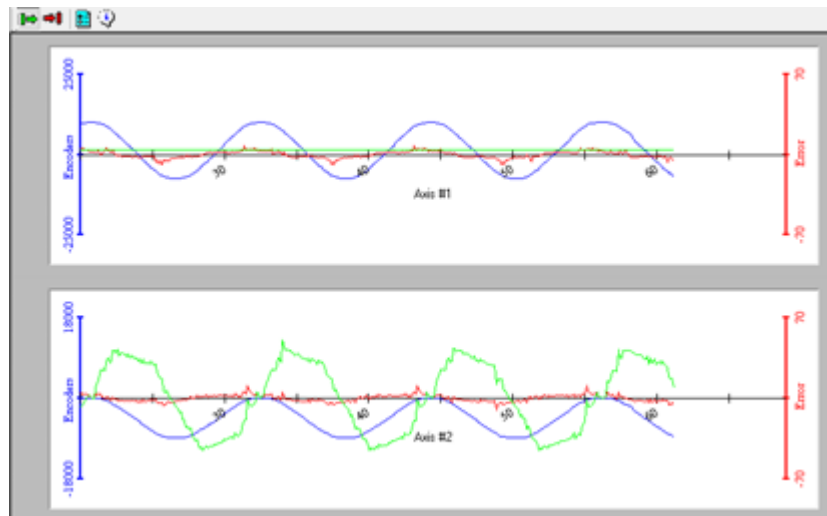

The data for each axis (1-8) is shown in a different chart. Sample charts for axes 1 and 2 are shown here.







To open the **Charts** window, perform one of the following:

- Click the Charts  icon in the toolbar.
- Select **View | Charts**.

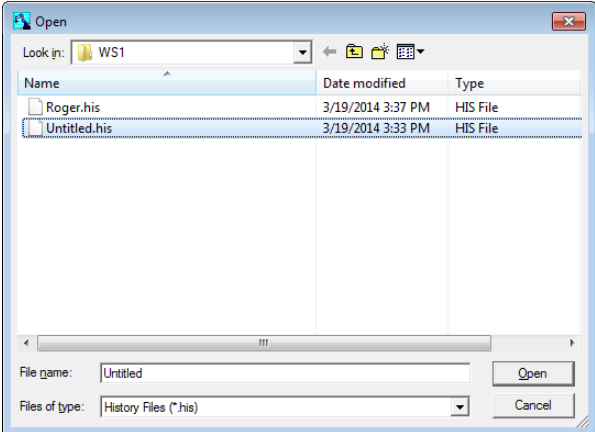
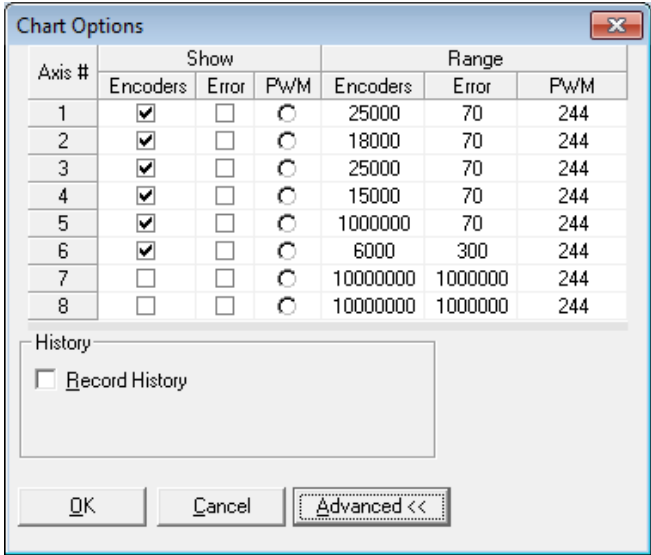
The following options are available in the **Charts** window toolbar:

Charts Window Options																																									
Icon	Option	Description																																							
	Start chart	Starts drawing the chart																																							
	Stop chart	Stops drawing the chart																																							
	Options	<p>Opens the Chart Options dialog box where you can select the data to be displayed in the chart(s)</p> <p>Click the data that you want displayed in the charts.</p> <p>The example shown below results in the display of the Encoder, Error and PWM of axis 1, as well as the display of the Encoder and Error for axes 2 through 6. Since each axis is shown in a different chart, six charts are displayed.</p> <div data-bbox="727 1008 1247 1654" data-label="Image"> <table border="1"> <thead> <tr> <th rowspan="2">Axis #</th> <th colspan="3">Show</th> </tr> <tr> <th>Encoders</th> <th>Error</th> <th>PWM</th> </tr> </thead> <tbody> <tr> <td>1</td> <td><input checked="" type="checkbox"/></td> <td><input type="checkbox"/></td> <td><input type="radio"/></td> </tr> <tr> <td>2</td> <td><input checked="" type="checkbox"/></td> <td><input type="checkbox"/></td> <td><input type="radio"/></td> </tr> <tr> <td>3</td> <td><input checked="" type="checkbox"/></td> <td><input type="checkbox"/></td> <td><input type="radio"/></td> </tr> <tr> <td>4</td> <td><input checked="" type="checkbox"/></td> <td><input type="checkbox"/></td> <td><input type="radio"/></td> </tr> <tr> <td>5</td> <td><input checked="" type="checkbox"/></td> <td><input type="checkbox"/></td> <td><input type="radio"/></td> </tr> <tr> <td>6</td> <td><input checked="" type="checkbox"/></td> <td><input type="checkbox"/></td> <td><input type="radio"/></td> </tr> <tr> <td>7</td> <td><input type="checkbox"/></td> <td><input type="checkbox"/></td> <td><input type="radio"/></td> </tr> <tr> <td>8</td> <td><input type="checkbox"/></td> <td><input type="checkbox"/></td> <td><input type="radio"/></td> </tr> </tbody> </table> <p>History</p> <p><input type="checkbox"/> Record History</p> <p>OK Cancel Advanced >></p> </div> <p>Any chart can be saved to a history (*.his) file. To do so:</p> <ol style="list-style-type: none"> 1. Select the Record History checkbox. 2. Click the Browse button (which becomes available). This window is displayed: 	Axis #	Show			Encoders	Error	PWM	1	<input checked="" type="checkbox"/>	<input type="checkbox"/>	<input type="radio"/>	2	<input checked="" type="checkbox"/>	<input type="checkbox"/>	<input type="radio"/>	3	<input checked="" type="checkbox"/>	<input type="checkbox"/>	<input type="radio"/>	4	<input checked="" type="checkbox"/>	<input type="checkbox"/>	<input type="radio"/>	5	<input checked="" type="checkbox"/>	<input type="checkbox"/>	<input type="radio"/>	6	<input checked="" type="checkbox"/>	<input type="checkbox"/>	<input type="radio"/>	7	<input type="checkbox"/>	<input type="checkbox"/>	<input type="radio"/>	8	<input type="checkbox"/>	<input type="checkbox"/>	<input type="radio"/>
Axis #	Show																																								
	Encoders	Error	PWM																																						
1	<input checked="" type="checkbox"/>	<input type="checkbox"/>	<input type="radio"/>																																						
2	<input checked="" type="checkbox"/>	<input type="checkbox"/>	<input type="radio"/>																																						
3	<input checked="" type="checkbox"/>	<input type="checkbox"/>	<input type="radio"/>																																						
4	<input checked="" type="checkbox"/>	<input type="checkbox"/>	<input type="radio"/>																																						
5	<input checked="" type="checkbox"/>	<input type="checkbox"/>	<input type="radio"/>																																						
6	<input checked="" type="checkbox"/>	<input type="checkbox"/>	<input type="radio"/>																																						
7	<input type="checkbox"/>	<input type="checkbox"/>	<input type="radio"/>																																						
8	<input type="checkbox"/>	<input type="checkbox"/>	<input type="radio"/>																																						

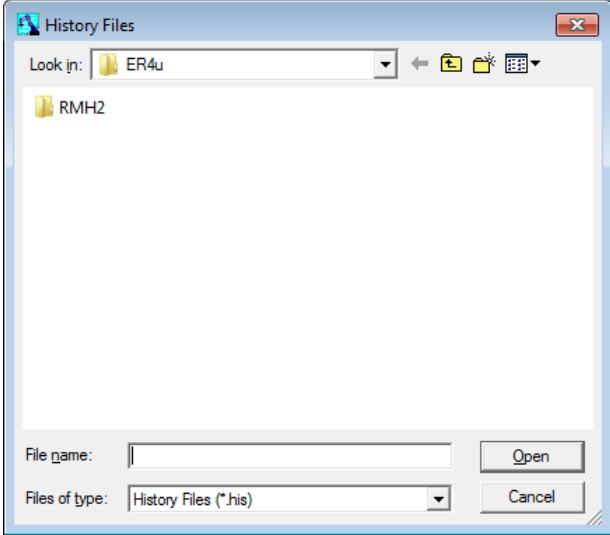
Charts Window Options																																																																							
Icon	Option	Description																																																																					
		 <p>3. Browse to the location in which the history files are saved, select a file to overwrite and click Open.</p> <p>4. The filename can be changed in the Chart Options dialog box so that it does not overwrite an existing file.</p> <p>To set the resolution of the chart for the Encoder, Errors and PWM:</p> <ul style="list-style-type: none"> Click the Advanced button in the Chart Options dialog box. The Range column is displayed.  <table border="1" data-bbox="683 1079 1284 1352"> <thead> <tr> <th rowspan="2">Axis #</th> <th colspan="3">Show</th> <th colspan="3">Range</th> </tr> <tr> <th>Encoders</th> <th>Error</th> <th>PWM</th> <th>Encoders</th> <th>Error</th> <th>PWM</th> </tr> </thead> <tbody> <tr> <td>1</td> <td><input checked="" type="checkbox"/></td> <td><input type="checkbox"/></td> <td><input type="radio"/></td> <td>25000</td> <td>70</td> <td>244</td> </tr> <tr> <td>2</td> <td><input checked="" type="checkbox"/></td> <td><input type="checkbox"/></td> <td><input type="radio"/></td> <td>18000</td> <td>70</td> <td>244</td> </tr> <tr> <td>3</td> <td><input checked="" type="checkbox"/></td> <td><input type="checkbox"/></td> <td><input type="radio"/></td> <td>25000</td> <td>70</td> <td>244</td> </tr> <tr> <td>4</td> <td><input checked="" type="checkbox"/></td> <td><input type="checkbox"/></td> <td><input type="radio"/></td> <td>15000</td> <td>70</td> <td>244</td> </tr> <tr> <td>5</td> <td><input checked="" type="checkbox"/></td> <td><input type="checkbox"/></td> <td><input type="radio"/></td> <td>1000000</td> <td>70</td> <td>244</td> </tr> <tr> <td>6</td> <td><input checked="" type="checkbox"/></td> <td><input type="checkbox"/></td> <td><input type="radio"/></td> <td>6000</td> <td>300</td> <td>244</td> </tr> <tr> <td>7</td> <td><input type="checkbox"/></td> <td><input type="checkbox"/></td> <td><input type="radio"/></td> <td>10000000</td> <td>1000000</td> <td>244</td> </tr> <tr> <td>8</td> <td><input type="checkbox"/></td> <td><input type="checkbox"/></td> <td><input type="radio"/></td> <td>10000000</td> <td>1000000</td> <td>244</td> </tr> </tbody> </table> <p>History</p> <p><input type="checkbox"/> Record History</p> <p>OK Cancel Advanced <<</p>	Axis #	Show			Range			Encoders	Error	PWM	Encoders	Error	PWM	1	<input checked="" type="checkbox"/>	<input type="checkbox"/>	<input type="radio"/>	25000	70	244	2	<input checked="" type="checkbox"/>	<input type="checkbox"/>	<input type="radio"/>	18000	70	244	3	<input checked="" type="checkbox"/>	<input type="checkbox"/>	<input type="radio"/>	25000	70	244	4	<input checked="" type="checkbox"/>	<input type="checkbox"/>	<input type="radio"/>	15000	70	244	5	<input checked="" type="checkbox"/>	<input type="checkbox"/>	<input type="radio"/>	1000000	70	244	6	<input checked="" type="checkbox"/>	<input type="checkbox"/>	<input type="radio"/>	6000	300	244	7	<input type="checkbox"/>	<input type="checkbox"/>	<input type="radio"/>	10000000	1000000	244	8	<input type="checkbox"/>	<input type="checkbox"/>	<input type="radio"/>	10000000	1000000	244
Axis #	Show			Range																																																																			
	Encoders	Error	PWM	Encoders	Error	PWM																																																																	
1	<input checked="" type="checkbox"/>	<input type="checkbox"/>	<input type="radio"/>	25000	70	244																																																																	
2	<input checked="" type="checkbox"/>	<input type="checkbox"/>	<input type="radio"/>	18000	70	244																																																																	
3	<input checked="" type="checkbox"/>	<input type="checkbox"/>	<input type="radio"/>	25000	70	244																																																																	
4	<input checked="" type="checkbox"/>	<input type="checkbox"/>	<input type="radio"/>	15000	70	244																																																																	
5	<input checked="" type="checkbox"/>	<input type="checkbox"/>	<input type="radio"/>	1000000	70	244																																																																	
6	<input checked="" type="checkbox"/>	<input type="checkbox"/>	<input type="radio"/>	6000	300	244																																																																	
7	<input type="checkbox"/>	<input type="checkbox"/>	<input type="radio"/>	10000000	1000000	244																																																																	
8	<input type="checkbox"/>	<input type="checkbox"/>	<input type="radio"/>	10000000	1000000	244																																																																	

Charts Window Options		
Icon	Option	Description
	History	<p>Opens the History Files Window. Select the desired history (*.his) file from the list or browse to locate it.</p>  <p>Note: To open a history file you must first stop drawing the chart.</p>
	Legend	<p>Displays the colors used in the charts for Encoders, Error and PWM.</p> <p><i>Encoders – Blue</i> <i>Error – Red</i> <i>PWM – Green</i></p>

4. Homing and Control

4.1. GENERAL

The robot and peripheral axes location is monitored and controlled using encoders. To initialize the encoders and to obtain consistent performance, the axes must first reach a predefined position known as *hard home*. All recorded positions and movements refer to the hard home position. The homing procedure finds the hard home for the selected axes.

SCORBASE offers two commands relating to the home position.

- **Search Home** is the procedure for homing. During **Search Home**, each axis is homed separately. The controller activates the currently homed motor axis, until its micro-switch is pressed. Then the controller initializes the axis encoder counter and turns to home the next axis. After all configured axes are homed, the homing procedure ends.
- **Go Home** sends the selected axes to a position where the values of all encoders are zero.

Note: This command does not home the axes.

The two commands are available in three levels:

- **Search / Go home all** (applies for all active axes)
- **Search / Go home robot** (applies for the robot)
- **Search / Go home peripherals** (applies for axes 7 & 8).

4.2. HOMING

This section covers the homing functions of the robot in SCORBASE.

4.2.1. Search Home All Axes Command

To start the homing procedure, do one of the following:

- Select **Run | Search home - all axes**.



- Click the **Search Home** icon.

A window opens displaying the number of the axis currently being homed. Each time an axis is successfully homed, a checkmark is displayed next to the axis number. After the five axes and the gripper have been homed, a checkmark is displayed next to Robot.



To abort homing while the procedure is still in progress, perform one of the following:

- Press **[F9]** (Stop command)
- Press the red **EMERGENCY** button on the controller.
- Press the **EMERGENCY** key on the Teach Pendant.

If the homing procedure fails, a message is displayed.

The **Search Home - All Axes** command executes the robot's homing procedure as well as that of any peripheral devices that have been configured in the **Options | Peripherals Setup** menu. This command can only be performed when SCORBASE is On-Line.

If the system has already been homed, and you change SCORBASE to Off-Line mode, there is no need to home the system again when you return to On-Line mode.

When SCORBASE is in Off-Line Mode, or when RoboCell is installed and is in Simulation Mode, the homing procedure is not required. The homing procedure initializes Joint and XYZ values according to a software definition. All encoders are set to 0, while the robot Cartesian coordinates are set according to a software model.

4.2.2. Search Home – Robot Command

This command runs the homing procedure for the robot. Homing of the peripherals is enabled only after the system has been homed once.

4.2.3. Search Home – Peripherals Command

This command runs the homing procedure for the configured peripherals. Homing of the robot is enabled only after the system has been homed once.

4.3. GO HOME COMMAND

After the axes have been homed, select **Run | Go Home - All Axes** to send the axes back to their home position at any time. This command sends the robot and peripherals to a position where the axes encoders value equals zero. The **Go Home** command does not run the homing procedure.

Selecting the **Go Home - Robot** or **Go Home - Peripherals** command sends the selected axis to its home position.

4.4. ON-LINE MODE / OFF-LINE MODE

SCORBASE can run either in On-Line or in Off-Line mode. In On-Line mode, SCORBASE communicates with the controller over the USB channel. If the Control On state is selected, SCORBASE controls the robot, peripherals and I/O device. In Off-Line mode, SCORBASE can be used only in the Control Off state (useful for programming and debugging). The active mode is displayed in the status bar.

To change to On-Line, select **Options | On-Line**.

To change to Off-Line, select **Options | Off-Line**.

If SCORBASE is opened in On-Line, or On-Line is selected from the Options menu, this message is displayed as SCORBASE searches for the controller:

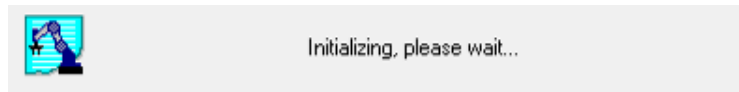

If the controller is detected, On-Line mode is activated.

If the controller is not detected, Off-Line remains the active mode.

4.5. CONTROL ON / CONTROL OFF – CON/COFF

The Control On state enables servo control of the axes. This state is available only in On-Line mode. In the Control Off state, axis movement commands cannot be executed. The Control state (On or Off) is displayed in the lower right corner of the status bar.

To enable control of the axes, do one of the following:

- Select **Options | Control On**.

- Click the **Control On**  icon.

- Press the **F5** key.

To disable control, do one of the following:

- Select **Options | Control Off**.



- Click the **Control Off** icon.

If you have disabled control and SCORBASE opens in On-Line mode, or On-Line mode is selected after detection of the controller, this prompt is displayed:

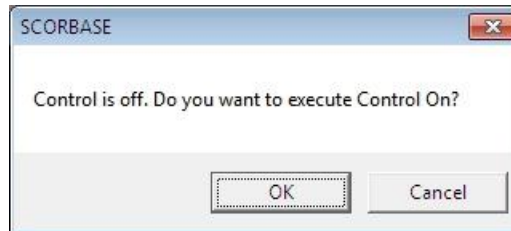

Press **OK** to enable control, or press **Cancel** to remain in the Control Off state.

The controller automatically disables control if an impact condition, trajectory error, or thermic overload error occurs during execution of a movement command. If you attempt to move the axes when control is disabled, this error message is displayed:



When SCORBASE is in Off-Line mode, the Control state cannot be altered.

5. Position Definition

Every SCORBASE project includes a set of pre-defined positions and a program that sends the robot from one position to the other. Prior to running a program all the positions used in that program should be defined. SCORBASE offers various tools to define and store positions that are used in the programs.

The following SCORBASE tools are used in the position definition process.

- Manual Movement Dialog Box
- Teach Positions Dialog Box
- Robot Movement Dialog Box
- Position Data Dialog Bars
- Positions Window

To activate the dialog boxes which are most useful for position definition, select **Window | Teach & Edit**.

Any of the following four methods can be used for position definition:

Methods for Position Definition		
No.	Method	Level
1	Absolute position Joint coordinates	1, 2, Pro
2	Relative position Joint coordinates	2, Pro
3	Absolute position Cartesian coordinates	2, Pro
4	Relative position Cartesian coordinates	2, Pro

Note: Peripheral position definition can only be performed in the Pro level.

5.1. JOINT AND CARTESIAN COORDINATE SYSTEMS

Defining a position in SCORBASE can be done by using either the Joint or Cartesian coordinate systems. In both systems, a robot position is defined using five parameters derived from the data supplied by the five axes encoders. An encoder is an angular movement sensor attached to the axes motor.

A Peripheral position is always defined using one variable that stores the sensor output (encoder value) of that position.

5.1.1. Joint Coordinate System

A robot position in Joint coordinates is defined by five angle values, representing each angle of the joints. The joint names are Base, Shoulder, Elbow, Pitch, and Roll.

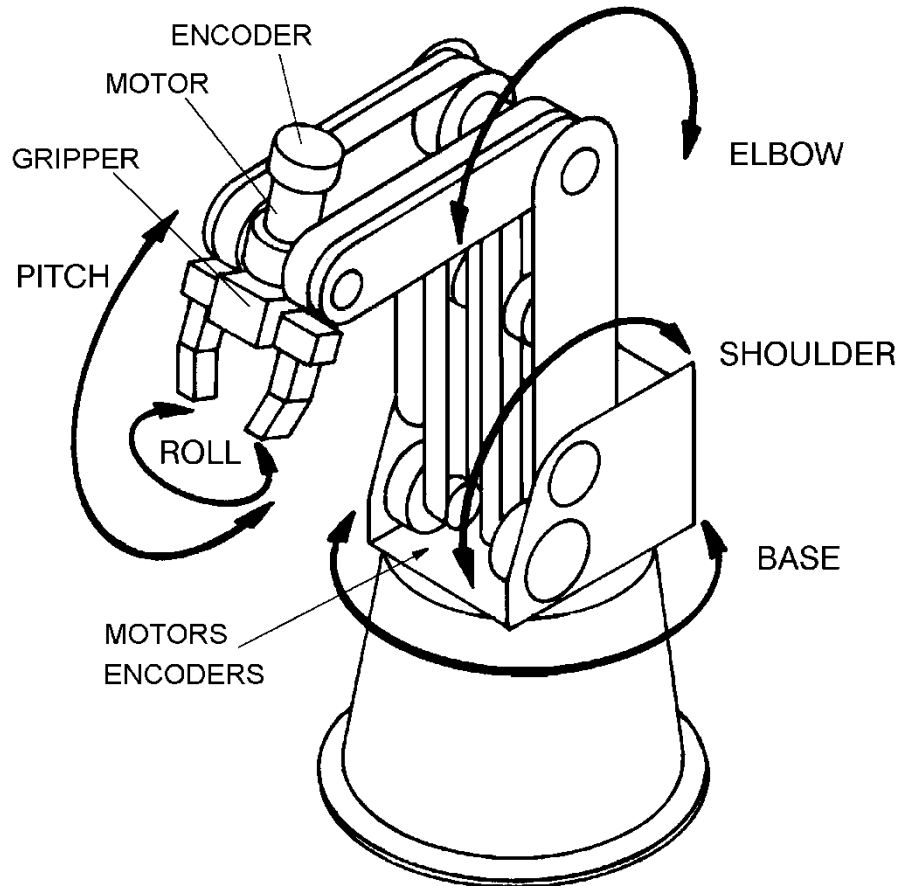

For example, after homing, the robot position in Joints coordinates is:

Axis #1 - Base = (0°)

Axis #2 - Shoulder = (-120°)

Axis #3 - Elbow = (~95°)

Axis #4 - Pitch = (~88°)

Axis #5 - Roll = (0°)

5.1.2. Cartesian Coordinate System (XYZ)

A robot position in Cartesian (or XYZ) coordinates is defined by these parameters.

- The distance of the robot's Tool Center Point (TCP) from the point of origin (the center bottom of the robot base), along the three axes that describe three-dimensional space (X,Y,Z)
- The Pitch (P) and Roll (R) angles of the gripper, specified in angular units

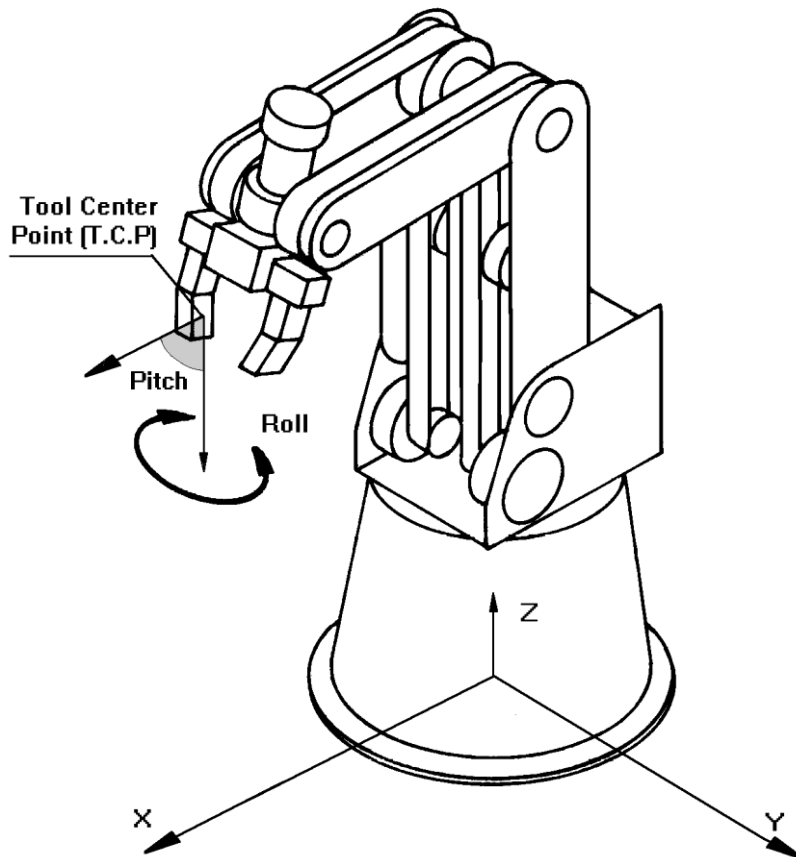

For example, after homing, the robot position in Cartesian coordinates is defined as:

X = (~169) [mm]

Y = (0) [mm]

Z = (~503) [mm]

Pitch = (~63°)

Roll = (0°)

A position recorded in one coordinate system can be converted by SCORBASE to another coordinate system.

5.2. ABSOLUTE AND RELATIVE POSITIONS

SCORBASE offers two methods of defining a robot or peripheral position: *absolute* and *relative*. The two methods are applicable in Cartesian and in Joint coordinates.

An *absolute* position is defined using all five robot position parameters. If the Joint coordinate system is used, the robot position is defined using the Base, Shoulder, Elbow, Pitch, and Roll angles. In the XYZ coordinate system, a position is defined using the X, Y, Z values in millimeters, and the Pitch and Roll angles in degrees. An absolute position is usually a fixed position in world space.

A *relative* position is a position whose coordinates are defined as an offset from *reference position* coordinates. If the coordinates of the reference position change, the relative position moves along with it, maintaining the same offset. A relative position can be defined in either Cartesian or Joint coordinate values.

A position can also be defined as *relative to current*. In this case, the relative position is calculated as an offset from the coordinates of the current robot position.

5.3. RECORD AND TEACH

Although the terms *teach* and *record* are often used interchangeably, SCORBASE makes the following distinction:

Record position: defines a robot position in a Joint coordinates system.

Teach position: defines a robot position in a Cartesian coordinates system.

5.4. MANUAL MOVEMENT DIALOG BOX

Recording a robot position (in Joint coordinates) is done by manipulating the robot to the required position and then recording it. The Manual Movement dialog box allows direct control and manipulation of the robot and peripheral axes.

The Manual Movement dialog box is automatically opened when a project is opened, or when the **Window | Teach & Edit** display setting is selected.

To display the Manual Movement dialog box when there are no open projects, select **View | Manual Movement**. This dialogue box is displayed:

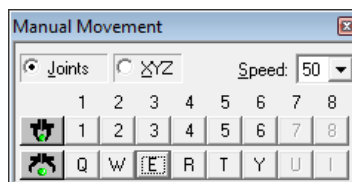

Note: Axis 6 is not applicable for SCORBOT-ER 2u. Axes 7 and 8 are only applicable when defined using the **Options | Hardware Setup** dialog box.

The following chart explains how clicking the buttons in the Manual Movement dialog box (or pressing the corresponding keys on the keyboard) controls the robot and peripheral movements.

When Joints is selected, clicking the buttons (or pressing the corresponding keys on the keyboard) moves one robot axis at a time, as described below:

Joints	
Keys	Joint Motion
1 / Q	Rotates the BASE right and left
2 / W	Moves the SHOULDER up and down
3 / E	Moves the ELBOW up and down
4 / R	Moves the wrist (PITCH) up and down

5 / T	Rotates the wrist (ROLL) right and left
6 / Y	Opens and closes gripper via servo control
7 / U	Moves peripheral axis #7 (if connected)
8 / I	Moves peripheral axis #8 (if connected)

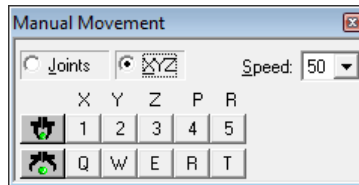

When XYZ is selected as shown here, clicking the buttons (or pressing the corresponding keys on the keyboard) moves the TCP, as described below.



Movements in XYZ mode are sometimes a combination of simultaneous movements of a few axes.

XYZ	
Keys	XYZ Motion
1 / Q	TCP moves along X-axis (back and forth)
2 / W	TCP moves along Y-axis (right and left)
3 / E	TCP moves along Z-axis (up and down)
4 / R	Axes move in order to change the gripper's pitch angle; the TCP position does not change
5 / T	The gripper rolls; the TCP position does not change

The Gripper options are described in this table:

Gripper Options		
Icon	Option	Description
	Open Gripper	Completely opens the gripper
	Close Gripper	Completely closes the gripper

The robot can be manipulated from the Manual Movement dialog box before it has been homed in Joint mode only. In fact, it is often necessary to bring the robot into a more suitable position before initiating the homing routine. However, an axis limit error message may be displayed during manipulation of a robot that has not been homed.

Movement of an axis continues as long as the button or key is pressed, or until a software or hardware limit is reached.

5.5. ROBOT MOVEMENT DIALOG BOX

The Robot Movement dialog box, shown here, enables control over the robot in XYZ and Joint modes.

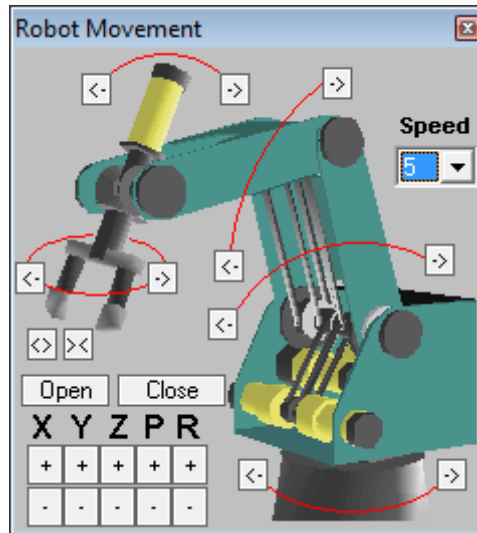

Clicking on an axis image or the XYZPR buttons moves the robot as described above in the Manual Movement Dialog Box section.

To open the Robot Movement dialog box, select **View | Robot Movement**.

5.6. TEACH POSITIONS DIALOG BOX

The Simple/Expanded Teach Positions dialog box enables the following:

- Teaching positions (in Cartesian coordinates).
- Recording positions (in Joint coordinates).
- Sending the axes to the recorded positions (when program is not running).
- Go to Position
- Go Linear
- Go Circular

To display the description of the function of each icon in the Teach Position dialog box, simply place the mouse on the desired icon without clicking a mouse button.



The user can define 1,000 positions. A higher computer (CPU and memory) can hold more positions.

5.6.1. Simple (Level 1)

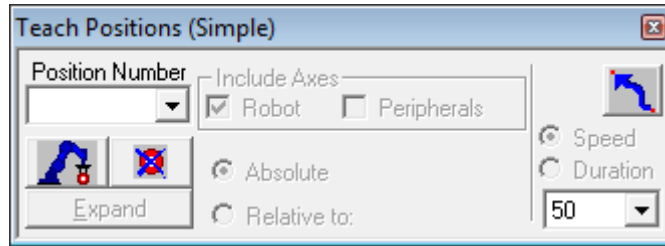
The Teach Positions (Simple) dialog box is shown here:



The Teach Positions (Simple) dialog box offers the following options:

Simple Dialog Box		
Option	Level	Description
Position Number	1, 2 & Pro	A numerical name for position
 Record	1, 2 & Pro	Records the current robot position (in joint coordinates) to the position displayed in the position number field
 Delete	1, 2 & Pro	Deletes from memory the position in the position number field
 Go to Position	1, 2 & Pro	Executes the Go to Position command, which sends the robot's TCP (Tool Center Point) from its current position to the selected position
Speed	1, 2 & Pro	Selects the speed for all movement commands. 10 fastest, 1 slowest, 5 default

5.6.2. Simple (Advanced Level)

The Advanced (Level 2) Teach Positions dialog box is shown here:

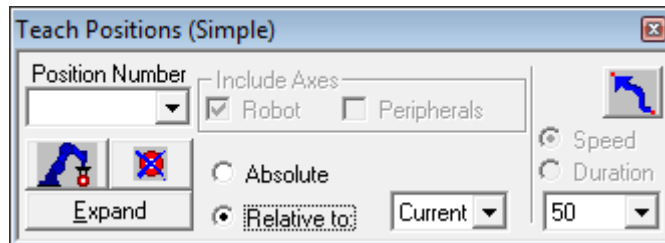

At the Advanced level, the Teach Positions dialog box offers all the commands available at Level 1, and also all of the following:

Advanced Teach Positions Dialog Box		
Option	Level	Description
Expand	2 & Pro	Opens the Teach Positions (Expanded/Simple) dialog box

Absolute / Relative to	2 & Pro	<p>Defines positions either as absolute or relative to another position.</p> <p>When Relative to is selected, a Relative to field is displayed. Select either an existing position or Current. A position that is Relative to Current means that the reference position is the robot position at the time it is sent to that position.</p> <p>Relative to is only available to Level 2 and Pro.</p>
------------------------	---------	--

5.6.3. Expand (Advanced and Pro Levels)

Click **Expand** to open the Teach Positions (Expanded) dialog box:

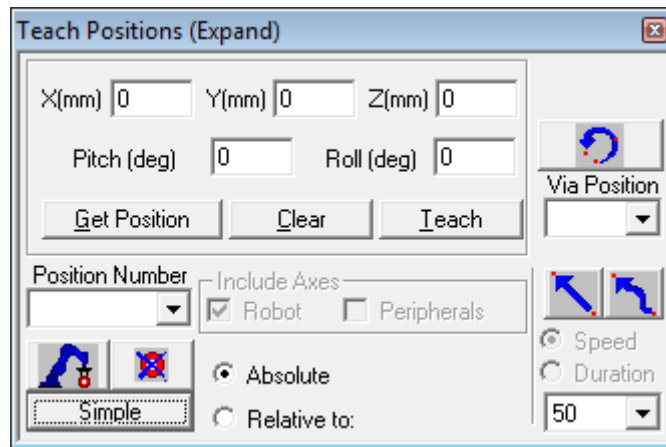

Teach Positions (Expand) Dialog Box for Level 2 (Advanced) User	
Option	Description
X(mm), Y(mm) Z(mm), Pitch(deg), Roll(deg)	Fields for displaying or changing the Cartesian coordinates of the selected position
Get Position	Displays the Cartesian coordinates of the selected position
Clear	Clears all position coordinate fields. The position data does not change.
Teach	Teaches position using the Cartesian Coordinate System
 Go Circular	<p>Executes the Go Circular to Position command. This command sends the robot in a circular path to the target position (in the position number field), via the position specified in the Via position field.</p> <p>The circular motion applies only to the robot.</p>
Via position	Selects the intermediate position through which the Go Circular movement passes

 <p>Go Linear to Position</p>	<p>Executes the Go Linear to Position command. Sends the axes in a straight line to the selected position</p>
<p>Simple</p>	<p>Toggles to the Teach Position (Simple) dialog box</p>

5.6.4. Simple (Pro Level)

The Teach Positions (Simple) Dialog Box (Pro Level) is shown here:

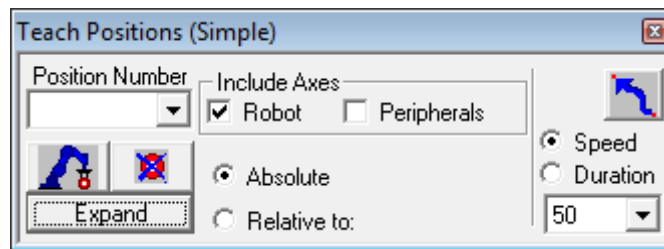

At the Pro level, the Simple Teach Positions dialog box offers the following additional commands:

Teach Positions (Simple) Dialog Box (Pro Level)		
Option	Level	Description
Include Axes	Pro	Instructs the controller to define coordinates for axes for Robot, Peripheral or both A peripheral position can be recorded only in the Pro level.
Duration	Pro	Defines the time it takes to complete a movement command. The time is defined in tenths of a second. For more information, see section 6.4 Axis Control Commands on page 45.

These commands remain available when the Teach Positions dialog box is expanded.

5.7. RECORDING POSITIONS (JOINT COORDINATES)

This section covers the procedures involved in recording positions in SCORBASE.

5.7.1. Record Absolute Position (Levels 1, 2 & Pro)

To record an absolute position:

1. Use either the Manual Movement dialog box or the Robot Movement dialog box to move the robot to the position you want to record.
2. Click the Teach Position dialog box.
3. Type a position number in the **Position Number** field, or select an existing position number if you want to modify (overwrite) a previously defined position.
4. Select **Absolute**.

5. Select **Include Axes (Robot and/or Peripherals)**:
 - a. **Robot**: to record a position for the robot axes.
 - b. **Peripherals**: to record a position for the peripheral axes (Pro level only).
6. To record the current position, click the Record Position icon.

5.7.2. Record Relative Position (Pro Level)

To record a relative position:

1. Make sure you have first defined a reference position.
2. Move the robot to the position whose coordinates you want to record as relative to another position.
3. In the **Position Number** field in the Teach Positions (Simple) dialog box, enter a new position number.
4. Select **Relative to**.
5. Enter a number (or select Current) for the reference position in the Relative to field.
6. Click **Record**. You have now recorded a relative position.

A position that is Relative to Current means the specified offset is computed from the location at which the robot is positioned at the time it is sent to the relative position. If the reference position changes, the relative position also moves.

5.8. TEACHING POSITIONS (XYZ COORDINATES)

In order to teach a position in XYZ coordinates, click **Expand**.

5.8.1. Teach Absolute XYZ Position (Levels 2 & Pro)

To teach an absolute XYZ position:

1. Click **Expand**.
2. Enter XYZ, Pitch and Roll values.
3. Click **Teach**.

To use existing position coordinates to define a new position (or modify that position's coordinates), perform this procedure:

1. In the **Position Number** field in the Teach Positions dialog box, select an absolute position number.
2. Click **Get Position**. The XYZPR values of the position now are displayed in the XYZ, Pitch and Roll fields. **Note:** If the position is relative, only the offset values are displayed.
3. In the **Position Number** field, enter a different number (or leave the position number if you want to modify that position).

4. To record a position for the robot axes, click **Robot**.
To record a position for the peripheral axes, click **Peripherals**.
To record positions for both, click **Robot and Peripherals**.
5. In one or more of the coordinate fields, enter a new value (in millimeters or degrees).
6. Click **Teach**.

Note: If you click **Record**, the current TCP coordinates are written to the selected position.

5.8.2. Teach Relative XYZ Position (Levels 2 & Pro)

To teach a relative XYZ position:

Make sure you have first recorded the reference position.

1. In the **Position Number** field, in the Teach Positions dialog box, enter the new position number.
2. Select **Relative to**, and enter the number of the reference position in the Relative to field. All XYZ coordinate fields are blank or show 0.
3. In one or more of the coordinate fields, enter a new value (in millimeters or degrees).
4. Click **Teach**.

A position that is relative to current means the specified offset are computed from wherever the robot is located at the time it is sent to the relative position.

If the reference position changes, the relative position moves accordingly.

5.9. POSITIONS WINDOW

This section covers the SCORBASE Positions Window.

5.9.1. Overview

The Positions window displays a list of the positions of the currently open project. The list is presented in tabular format. As default, the table presents position information in both the Joint Coordinate System and the Cartesian Coordinate System.

When fully open, the window is divided horizontally into two panels. By dragging the bottom edge of the window, you can reveal the bottom panel. The top panel displays all positions in the project (Position Inventory Panel). The bottom panel (Watch Panel) displays the positions which have been selected for watching.

Shown below, the Positions Window is fully opened to display both the Position Inventory Panel and the Watch Panel.

#	Coord.	Axis 1	Axis 2	Axis 3	Axis 4	Axis 5	Axis 7	Axis 8	Type
		X (mm)	Y (mm)	Z (mm)	Pitch (deg)	Roll (deg)	mm/deg	mm/deg	
1	Joint	-99.66	0.56	46.52	42.92	0.00			Abs. (Joint)
	XYZ	-64.99	-382.00	39.99	-90.00	0.00			
2	Joint	-43.54	-27.66	96.84	20.81	0.00			
	XYZ	210.42	-199.96	100.00	-90.00	0.00			Abs. (XYZ)
3	Joint	50.45	-21.88	81.89	30.00	-44.70			Abs. (Joint)
	XYZ	211.10	255.68	94.97	-90.00	-44.70			
5	Joint	-82.20	-0.37	48.83	41.54	0.00			Abs. (Joint)
	XYZ	52.02	-380.00	40.00	-90.00	0.00			

Each row in the top portion of the table represents a single position. To manipulate the list:

- Select a position (row).
- Right-click to display the popup window.

5.9.2. Position Popup Window

The Position popup window is shown here.

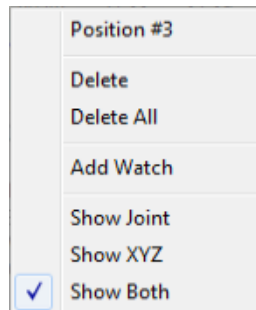

The Position Popup Menu options are summarized in this table:

Position Popup Menu Options	
Option	Description
Position No.	Displays the number of the position
Delete	Deletes the selected position
Delete All	Deletes all listed positions from the Position Inventory Panel and the SCORBASE memory
Add Watch	Copies the position data to the watch list, visible in the Watch Panel
Show Joint	Shows only Joint values of all positions
Show XYZ	Shows only the XYZPR of all positions
Show Both	Shows both Joint and XYZPR values of all positions

Note: The peripheral positions are always displayed using encoder counts.

5.9.3. Watch Popup Window

The Watch popup window is shown here:

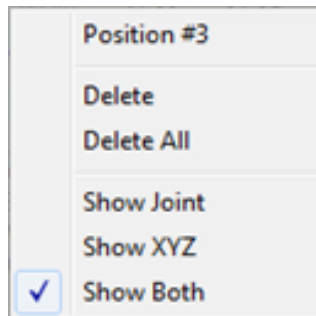

The Watch Popup window options are described here:

Watch Popup Window Options	
Option	Description
Position No.	Displays the number of the position.
Delete	Removes the selected position from the watch list, but does not affect its presence in the overall list
Delete All	Removes all listed positions from the watch list, but does not affect their presence in the overall list
Show Joint	Shows only Joint values of all positions. This can be set to a value different from the Position Inventory Panel.
Show XYZ	Shows only the XYZPR of all positions. This can be set to a value different from the Position Inventory Panel.
Show Both	Shows both Joint and XYZPR values of all positions

5.10. POSITION DATA DIALOG BARS

SCORBASE offers three dialog bars that display all axes, encoder counts and the robot position in reference to both the Cartesian Coordinate System (XYZ) and the Joint Coordinate System. All dialog bars are accessible at all levels via the View menu. They may also be opened or closed using the **View | Show All Dialog Bars** or **View | Close All Dialog Bars** commands.

5.10.1. Encoder Counts Dialog Bar

The **Encoder Counts** dialog bar, shown here, displays the current values of the encoders for each of the eight axes.



To display the **Encoder Counts** dialog bar, select **View | Dialog Bar | Encoders**.

The encoder values change whenever the axes are moved.

These values are set to 0 (or close to zero) after the Search Home All Axes command is executed.

5.10.2. XYZ Dialog Bar

The XYZ dialog bar displays the current Cartesian Coordinate System (XYZ PR) values of the TCP.

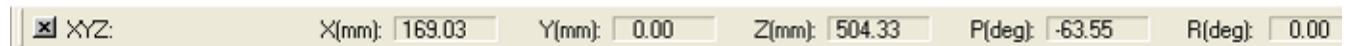

To display the XYZ dialog bar, select **View | Dialog Bar | XYZ**.

The values shown in the above example are the Joint values after the Search Home command is executed.

5.10.3. Joints Dialog Bar

The Joints dialog bar displays the angles between the two links of the joint, in degrees.



To display the Dialog bar, select **View | Dialog Bar | Joints**.

The values shown in the above example are the XYZ values after the Search Home command is executed.

5.11. USING A TEACH PENDANT WITH SCORBASE

The Teach Pendant is a hand-held terminal that gives the operator direct control of the robot and peripheral axes. In addition to controlling movement of the axes, the Teach Pendant may be used for recording positions, sending the axes to recorded positions, and other functions.

To control the axes from the Teach Pendant, SCORBASE must be operating in the On-Line mode, and the Teach/Manual switch on the Teach Pendant must be switched to Teach. This disables control of the axes from SCORBASE dialog boxes.

All Teach Pendant operations are reflected in the SCORBASE dialog boxes. For example, positions recorded by the Teach Pendant are displayed in the Position Number list in the Teach Positions dialog box; and encoder and XYZ values change in the Encoder Counts and XYZ dialog boxes.

The Teach Pendant operation is described fully in the Teach Pendant for Controller User Manual.

6. Program Editing

A SCORBASE program is a set of instructions written by the user to control the robot, peripheral equipment and to communicate with external I/O devices. This chapter explains how to create and edit a SCORBASE program.

The following tools are used for program editing:

- Program commands editor
- Command tree that lists all SCORBASE commands

6.1. OPENING AND CLOSING A PROGRAM

Every SCORBASE program is part of a SCORBASE project. A project also includes the user-defined positions, project data and, if RoboCell is installed, a virtual cell (3dc file). Only one project can be opened at a time.

To open a saved program, open the project containing the desired program by performing one of the following:

- Select **File | Open Project...**



- Click the Open an Existing Project icon.
- Press **Ctrl + O**.

In all cases, the *Load Project* window opens, prompting you to select the project that contains the program you want to edit.

The program is displayed in the Program Window.

To create a new project, perform one of the following:

- Select **File | New Project...**



- Click the Create a New Project icon.
- Press **Ctrl + N**.

By default, the new project is opened with the Teach & Edit layout. This layout displays four windows:

- Program Window that holds the SCORBASE program
- Manual Movement Dialog Box
- Teach Positions Dialog Box
- Workspace Window that shows:
 - Project data, i.e., positions, user program and graphical display (if installed)
 - SCORBASE Command Tree

The Program Window, shown below, contains the text of the SCORBASE program currently loaded. Its title bar displays the name of the project. Also shown by default is the programming toolbar. The toolbar contains a drop-down list of all subroutines available, for quick navigation.

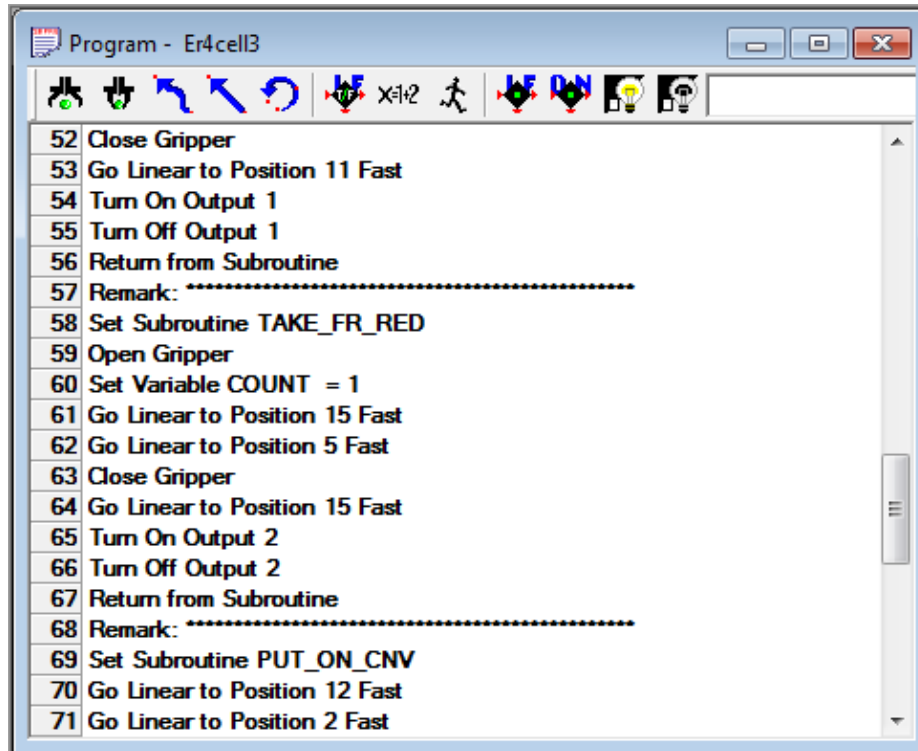

The Workspace Window contains two tabs to switch between the project files and the commands currently available. The Project tab is shown here:

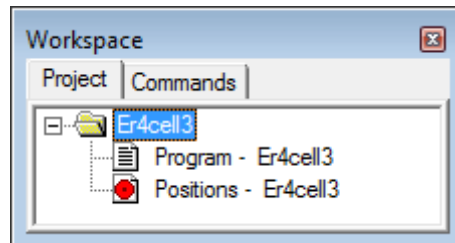

The **Commands** tab displays the Command Tree, which in turn displays all of the commands available for the currently set Experience Level.

6.2. PROGRAM EDITING TOOLS

SCORBASE is a text-based programming language in which every command is a single text line. SCORBASE programs are edited by means of the standard Windows text editing options, which can be accessed:

- Via the Edit menu.
- By pressing the designated keys.
- By right-clicking the mouse in the Program Window to open a pop-up menu.

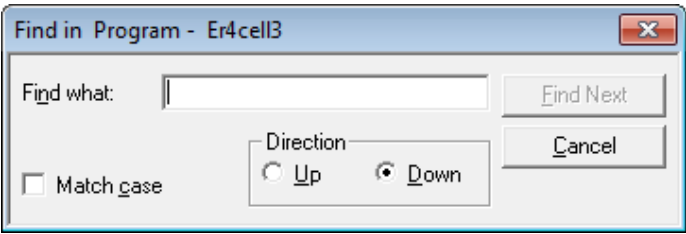
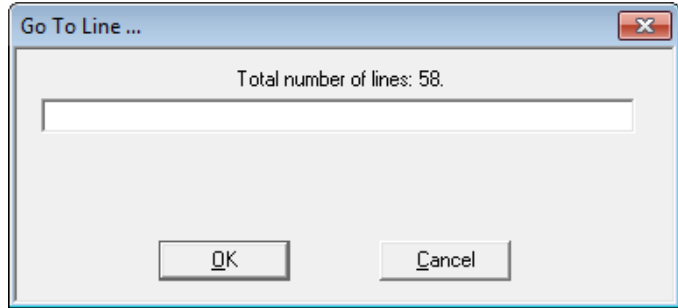
Program Editing Tools	
Option - Shortcut	Description
Cut - Ctrl+X	Deletes selected text or lines from the program, and places it on the Windows and SCORBASE clipboards
Copy - Ctrl+C	Places a copy of selected text or lines from the program on the Windows and SCORBASE clipboard
Paste - Ctrl+V	Inserts the contents of the SCORBASE clipboard into the program
Find - Ctrl+F	<p>Opens a dialog box (shown here) that allows you to search for any string, such as a command or text</p> 
Find Next - (F3)	Repeats the last Find operation for the next occurrence. (Accessible also from the Find dialog window)
Command/ Remark (*...)	<p>Inserts/deletes asterisk at beginning of a command line</p> <p>SCORBASE ignores command lines that start with an asterisk. This feature is useful for debugging.</p>
Go to Line	<p>Opens a dialog box (shown here) that displays the total number of lines in the program and prompts you for a line number. Type in the number. The program editor jumps to the line you specify.</p> 
Go to Selected Line	Automatically scrolls the Program Window to display the line which you have selected. This is useful for long programs when you have selected a particular line and then scrolled away from it. In very short programs which fit within a single window, this function has no visible effect.

In addition, use the keyboard for the following functions:

Additional Program Editing Functions	
Keyboard Shortcut	Function
[Ins]	Toggles between Insert Mode and Overwrite Mode. The currently active mode is shown in the Status bar at the very bottom of the SCORBASE window. In Insert Mode, a new command is inserted into the program above the line currently marked by the cursor.
[Del]	Deletes the line or lines currently marked by the cursor
[Ctrl+Home]	Brings the cursor to the first line of the program
[Ctrl+End]	Brings the cursor to the last line of the program
[PgUp]	Displays the previous page of program lines
[PgDn]	Displays the next page of program lines

6.3. ADDING AND EDITING COMMANDS

SCORBASE commands are organized in a Command Tree, which is displayed in the Workspace Window. SCORBASE only displays the commands which are available in the currently set Experience Level.

- At the Introductory level (Level 1), only basic commands are displayed in the Command Tree.
- At the Advanced level (Level 2), the number of commands is increased.
- At the Professional level (Pro Level), all commands are accessible.

To see the Command Tree, click the Command tab in the Workspace Window.

SCORBASE commands are grouped into these categories:

- Axis & Control
- Program Flow
- Inputs & Outputs
- Advanced - By default, this category is hidden. Select **Options | Advanced Options | Advanced Commands** to display these commands.
- Vision - By default, this category is hidden. Select **Options | Advanced Options | ViewFlex Commands** to display these commands.

Clicking on a category opens/closes the list of commands.

To add commands to a program, perform one of the following:

- Double-click the desired command in the Command Tree.
- Type the two letters written next to the command.
- Click the command icons in the Program Window (applicable only for selected commands).

If you are working in Insert Mode, the new command line is added above the currently selected (highlighted) line. If you are working in Overwrite Mode, the new command replaces the selected line.

Toggle between the two modes using the [Ins] key. Many commands open dialog boxes for completing the command line parameters.

To change a command parameter, click the command to re-open the command dialog box. Change the required parameter, and click OK to close the dialog box.

Note: For safety reasons, certain parameters are not accessible by the user, i.e., they are displayed as grayed, and can be changed only by Intelitek support personnel.

To delete, cut, copy and paste a line, use the standard Windows tools.

6.4. AXIS CONTROL COMMANDS

The Axis Control options, commands, and functions are described in the following tables.

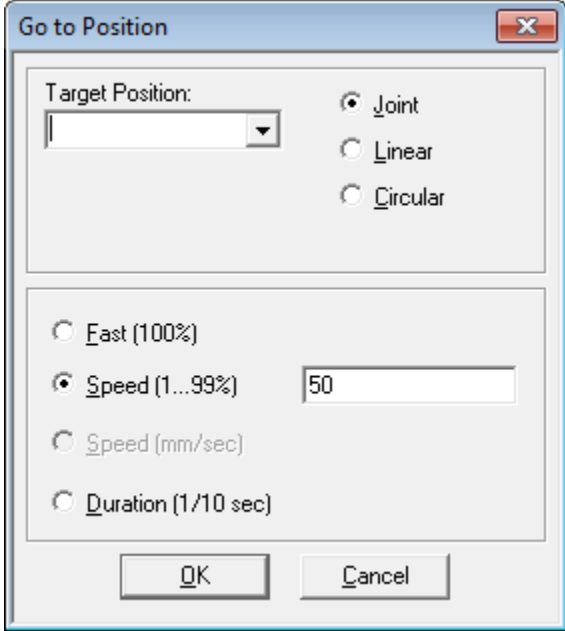

Axis Control Command Tree		
Level 1 – Introductory	Level 2 – Advanced	Pro – Professional

Axis Control Commands			
Icon	Command	Levels	Description
	OG Open Gripper	1,2,Pro	Fully opens the gripper
	CG Close Gripper	1,2,Pro	Fully closes the gripper (on itself, or on a grasped object)

Axis Control Commands			
Icon	Command	Levels	Description
	GP Go to Position	1,2,Pro	<p>Opens the Go to Position dialog box, shown here. The Go to Position command sends the robot to a recorded position, in the shortest time, using Point to Point (P to P) control. In Point to Point control, all axes move independently and there is no control over the TCP trajectory.</p> 

Movement Control	
Option	Description
Target Position	The destination of the movement. Enter a number or a variable in this field.

Speed/Duration Options	
Option	Description
Fast	Executes the movement at the fastest speed possible
Speed	Executes the movement at a slower speed . Enter a number from 1 through 99(%), or a variable, in the Speed field. Default: 50 (average speed).
Duration	Executes the movement in a specific amount of time. Enter the time in tenths of a second, or a variable. Available only in Pro Level.
Via Position	The position via which the destination of the movement is reached. Enter a number or a variable in this field.

Additional Movement Control Options			
Icon	Option	Level	Description
	GL Go Linear to Position #_Speed ...	2,Pro	<p>Sends the robot's TCP (tool center point) from its current position to the target position, along a linear path (straight line). The linear motion applies only to the robot axes. For linear motion, speed can also be defined in mm/s.</p> <div data-bbox="727 436 1286 1066" style="border: 1px solid gray; padding: 5px;"> <p>Go to Position X</p> <p>Target Position: <input type="text"/></p> <p> <input type="radio"/> Joint <input checked="" type="radio"/> Linear <input type="radio"/> Circular </p> <p> <input type="radio"/> Fast (100%) <input type="radio"/> Speed (1...99%) <input checked="" type="radio"/> Speed (mm/sec) <input type="text"/> <input type="radio"/> Duration (1/10 sec) </p> <p style="text-align: center;"> <input type="button" value="OK"/> <input type="button" value="Cancel"/> </p> </div>
	GC Go Circular to Position #_Speed...	2,Pro	<p>Sends the robot's TCP in a circular path to the target position, via the position specified in the Via Position field. The circular motion applies only to the robot.</p> <p>Note: The Circular command follows the circle defined by the three positions (current TCP position, target position, and the intermediate position specified in the Via position field).</p>
	Via Position		The position via which the destination of the movement is reached. Enter a number or a variable in this field.

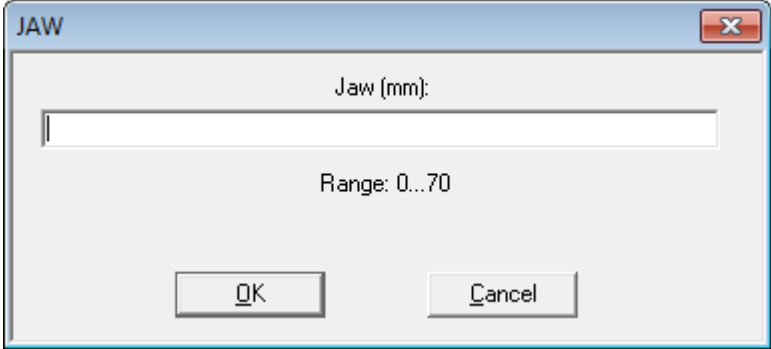
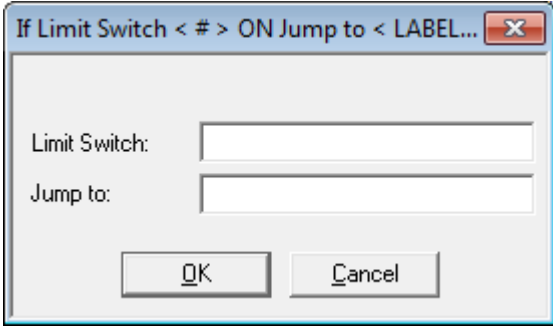
Additional Movement Control Options			
Icon	Option	Level	Description
	JA Jaw	2,Pro	<p>Moves the gripper's jaw to the specified span. The command opens this dialog box:</p>  <p>Enter a number or a variable in the Jaw field.</p> <p>Note: Accuracy cannot be guaranteed if the width is less than 5 mm or greater than 65 mm.</p> <p>Jaw activates Servo Control for the gripper motor, whereas Open Gripper and Close Gripper commands do not use the gripper axis Servo Control.</p> <p>Unless you need the Jaw command for a specific application, the Open Gripper and Close Gripper commands are recommended.</p> <p>Note: This command is not available for SCORBOT-ER 2u.</p>
	IL If Limit Switch < # > on jump to <Label>	2,Pro	<p>The IL is a conditional jump command. It causes program execution to jump to the line that contains the specified Label, if the selected axis micro switch is pressed (On). The command opens this dialog box.</p>  <p>Enter the Axis number or a variable in the Limit Switch field.</p> <p>Enter the name of a Label in the Jump to field.</p>

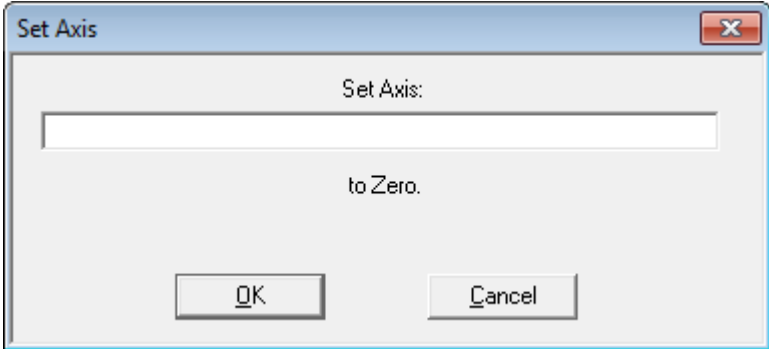
Additional Movement Control Options			
Icon	Option	Level	Description
	RP Record Position #_	Pro	<p>When the Record Position command is executed (during program execution), the controller records the current position data to the specified position. The command opens this dialog box:</p>  <p>Record present position as position:</p> <p>Enter a position number or a variable in the Record Present Position as Position field.</p> <p>The Record Position command is useful when a position (and all relative positions that refer to that position) must be relocated, during program execution. This command updates the position data.</p>
	SA Set Axis #_ ... (to Zero)	2,Pro	<p>Initializes (sets to 0) the encoder count of the selected axis. The command opens this dialog box:</p>  <p>Set Axis:</p> <p>to Zero.</p> <p>Enter a number or a variable in the Axis field.</p>

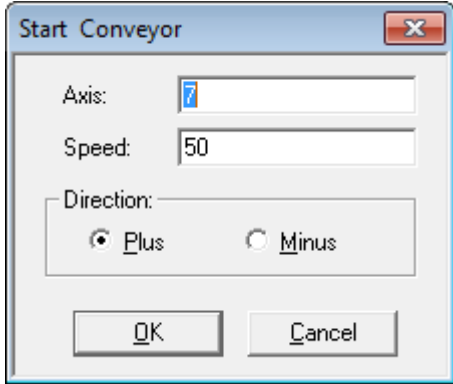
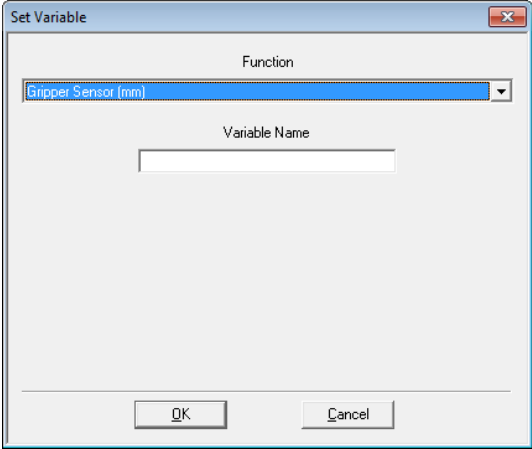
Additional Movement Control Options			
Icon	Option	Level	Description
	SC Start Conveyor	Pro	<p>Starts the conveyor, as a speed-controlled conveyor. Movement of the conveyor continues until a Stop Conveyor (ST) command is encountered.</p> <p>The command opens this dialog box:</p>  <p>Note: When operating a speed controlled conveyor by means of the Start/Stop Conveyor commands, do not record positions, and/or use the Set Axis (to Zero) command for the conveyor, in the same program.</p>
	ST Stop Conveyor	Pro	<p>Stops the continuous motion of a conveyor that was initiated by a Start Conveyor (SC) command</p>
	SG Set Variable to Gripper Sensor	Pro	<p>Assigns the value of the gripper opening (in mm) to a variable. This command is useful when there is a need to measure the object in the gripper, or to check the gripper status (open, closed or gripping an object).</p>  <p>In the Name field, enter the name of the variable.</p> <p>For more information on variables, see section 7 Variable Programming on page 75.</p> <p>Note: This command is not available for SCORBOT-ER 2u.</p>

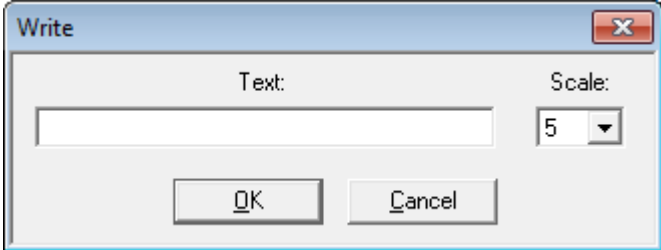
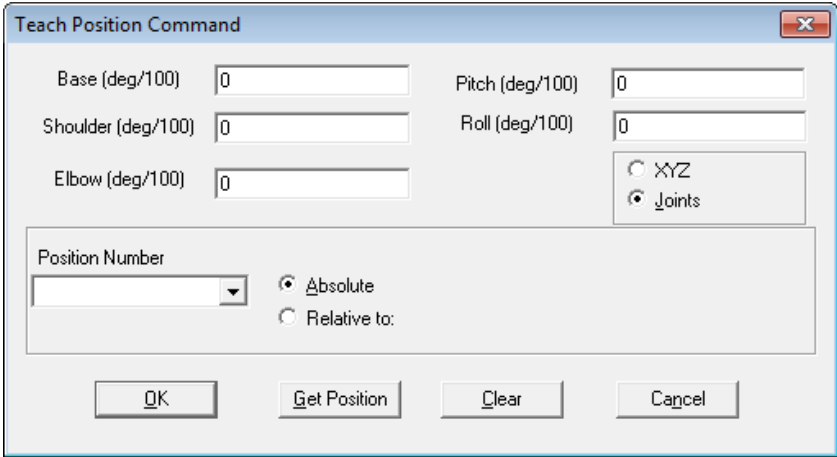
Additional Movement Control Options									
Icon	Option	Level	Description						
	WR Write		<p>Commands the gripper to convert the letters specified into lettering on the workpiece. The size is controlled by the Scale setting (1-10). The Write dialog box is shown here.</p> 						
	CN ControlOn		Enables axis control by the controller						
	CF ControlOff		Disables axis control by the controller						
	TJ Teach Position By Joints	Pro	<p>Teaches the position as defined by the absolute positions of the joints. The Teach Position (Absolute Joints) Dialog Box is shown here:</p> 						
			<table border="0" style="width: 100%;"> <tr> <td style="width: 30%;"></td> <td style="width: 30%;">Get Position</td> <td style="width: 40%;">Copies the values of the robot's current position into the appropriate boxes.</td> </tr> <tr> <td></td> <td>Clear</td> <td>Clears the values from all the boxes</td> </tr> </table>		Get Position	Copies the values of the robot's current position into the appropriate boxes.		Clear	Clears the values from all the boxes
	Get Position	Copies the values of the robot's current position into the appropriate boxes.							
	Clear	Clears the values from all the boxes							

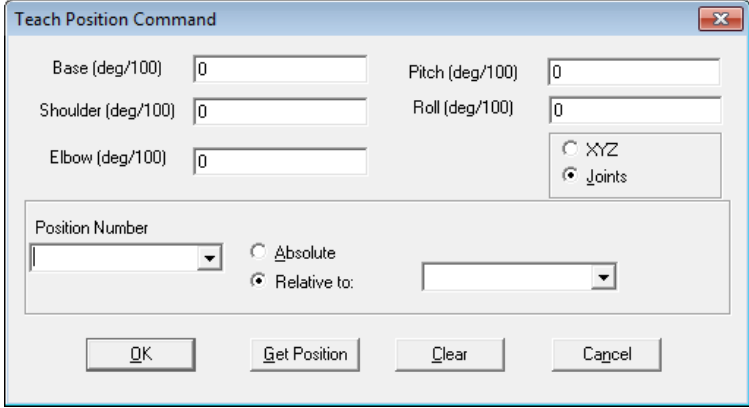
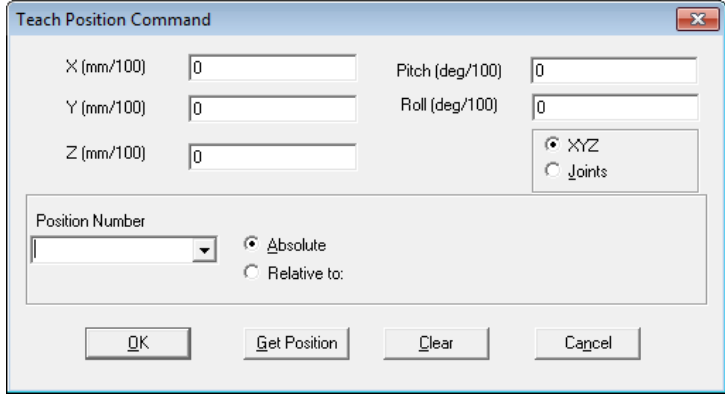
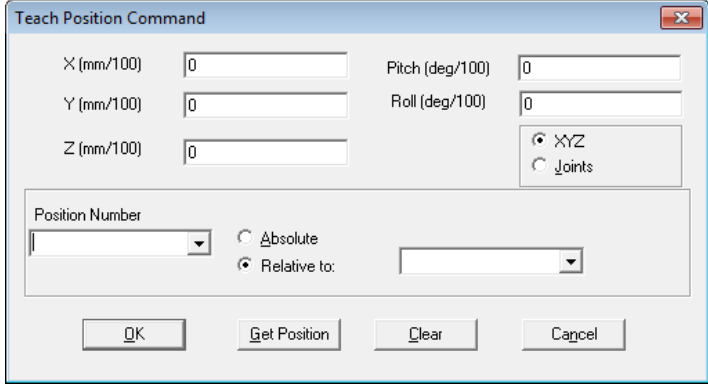
Additional Movement Control Options			
Icon	Option	Level	Description
	RJ Teach Position By Joints Relative to Position	Pro	<p>Teaches the position as defined by the positions of the joints relative to another defined position. The Teach Position (Relative Joints) Dialog Box is shown here:</p> 
	TX Teach Position by XYZ	Pro	<p>Teaches the position as defined by the absolute Cartesian coordinate of the TCP (Tool Center Point).</p> 
	RX Teach Position by XYZ Relative to Position	Pro	<p>Teaches the position as defined by the Cartesian coordinate of the TCP (Tool Center Point) relative to another defined position.</p> 

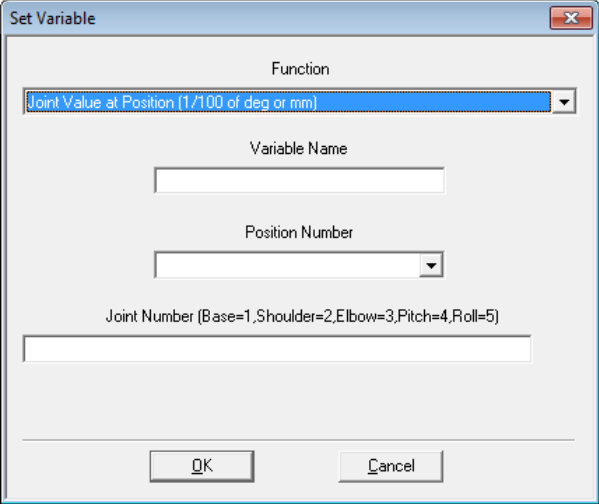
Additional Movement Control Options			
Icon	Option	Level	Description
	SJ Set Variable to Joint Position		<p>Allows you to set a variable to the value of a specified joint at a specified position number. Set Variable to Joint Position Dialog Box is shown below.</p>  <p>An integer between 1 and 5 is inserted for the Joint number, as follows:</p> <ul style="list-style-type: none"> Base 1 Shoulder 2 Elbow 3 Pitch 4 Roll 5 <p>You may also insert a variable which contains one of these values.</p>

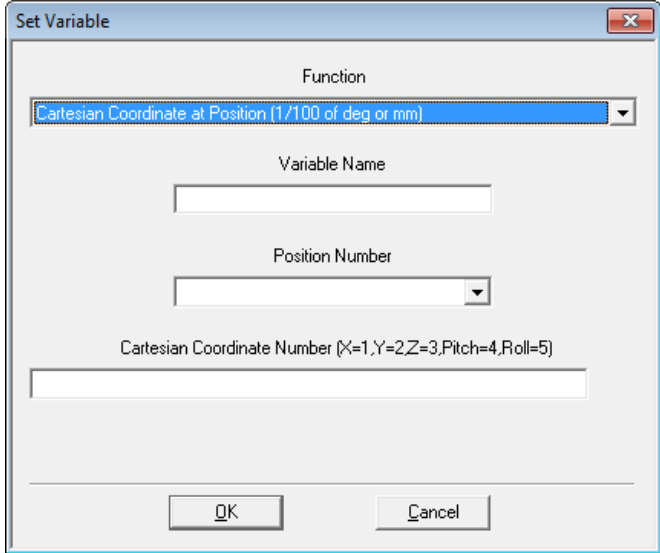

Additional Movement Control Options			
Icon	Option	Level	Description
	SX Set Variable to Cartesian Position		<p>Allows you to set a variable to the value of a specified Cartesian coordinate at a specified position number. The Set Variable to Cartesian Position (Relative XYZ) Dialog Box is shown here.</p>  <p>An integer between 1 and 5 is inserted for the Joint number, as follows:</p> <ul style="list-style-type: none"> Base 1 Shoulder 2 Elbow 3 Pitch 4 Roll 5 <p>You may also insert a variable which contains one of these values.</p>

6.5. PROGRAM FLOW COMMANDS

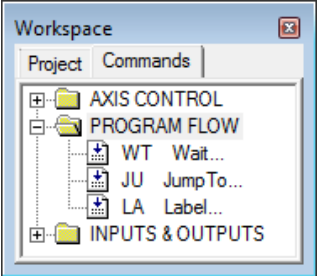
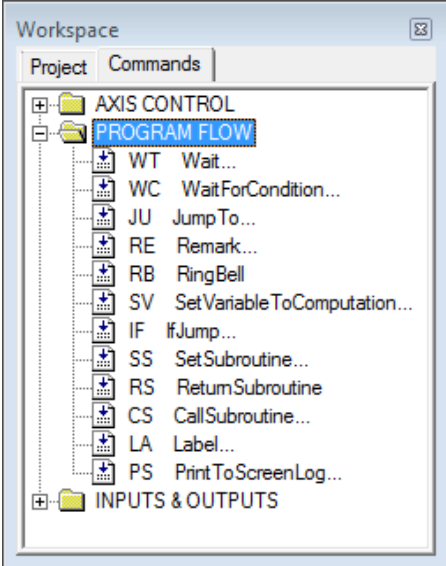
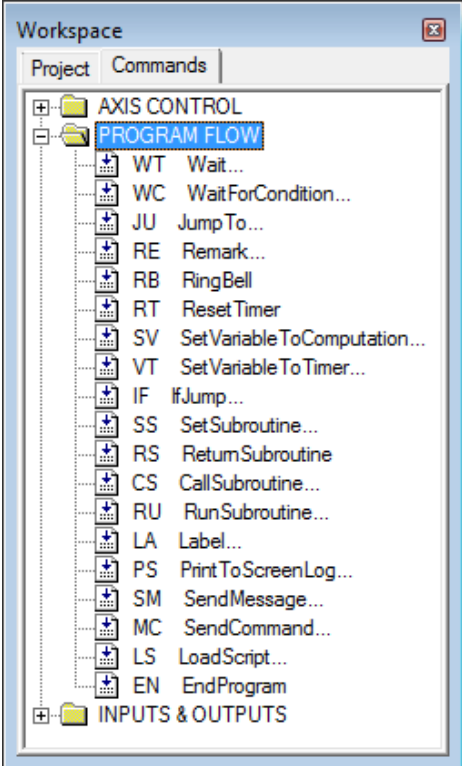
The Program Flow commands are summarized in the tables below.

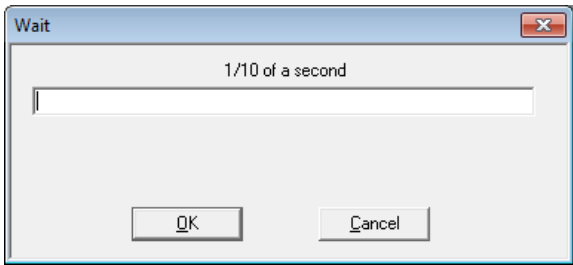
Program Flow Branch Command Tree		
Level 1 – Introductory	Level 2 – Advanced	Pro – Professional
		

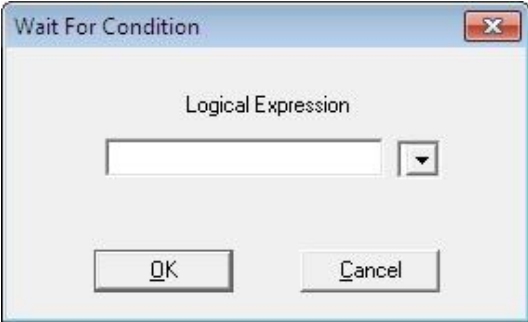
Program Flow Commands			
Icon	Command	Levels	Description
	WT Wait (10ths of second)	1,2,Pro	Halts program execution for a time specified in tenths of a second. The command opens this dialog box: 
	WC Wait For Condition	2,Pro	Halts program execution until the defined condition is fulfilled. The command opens this dialog box:

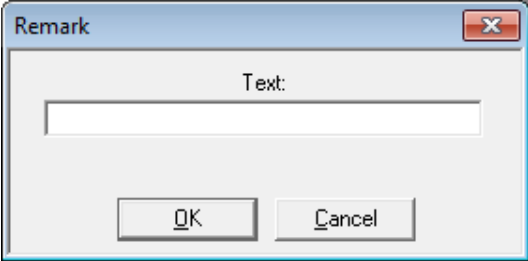
Program Flow Commands			
Icon	Command	Levels	Description
			
	JU Jump to	1,2,Pro	<p>This unconditional jump command causes the program pointer to jump to the line that contains the specified Label. The command opens this dialog box:</p>  <p>When the Jump command is used, Jump is checked in the dialog box. You can modify the Jump command to an IF jump command (conditional jumping) only in Levels 2 and Pro.</p>
	RE Remark	2,Pro	<p>Allows insertion of a comment line for explanation and documentation into the program. The command opens this dialog box:</p>  <p>Up to 47 characters of text may be inserted, including spaces.</p>
	RB Ring Bell	2,Pro	When executed, this command produces a beep, using the computer's internal loudspeaker.
	RT Reset Timer	Pro	<p>SCORBASE uses a timer that measures time in units of tenths of a second. The timer starts operating when SCORBASE is opened.</p> <p>The Reset Timer command resets the value of the SCORBASE timer to 0.</p> <p>To use the timer, the timer value must be assigned to a variable, using the Set</p>

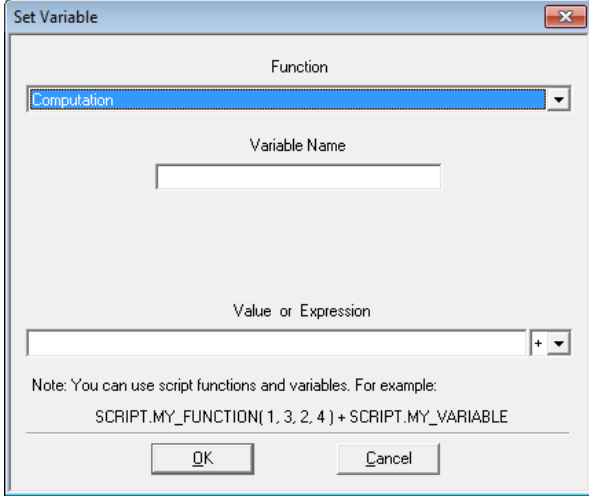
Program Flow Commands			
Icon	Command	Levels	Description
	SV Set Variable to Computation	1,2,Pro	<p>Variable command.</p> <p>Allows you to assign a value, or an expression (result of a specific computation), to a variable.</p> <p>The command opens the Set Variable dialog box (Computation is selected by default).</p>  <p>In level 2, the Set Variable value can only be a result of computation. In the Pro level, variable values can be derived from other sources. For more information.</p> <p>Variable Name</p> <p>The first character of the variable name must be a letter.</p> <p>Value or Expression</p> <p>Enter a value or a formula.</p> <p>To set the variable to a fixed value, enter a number (in the range of +/-1000000).</p> <p>To set the variable to the result of a computation, enter a string that consists of two arguments and an operator. An argument can be either an integer or a variable (e.g., fun*2).</p> <p>Click the arrow to see a list of operators, or use the list of operators, which is shown below.</p>

The Operators Drop-Down List is shown here:



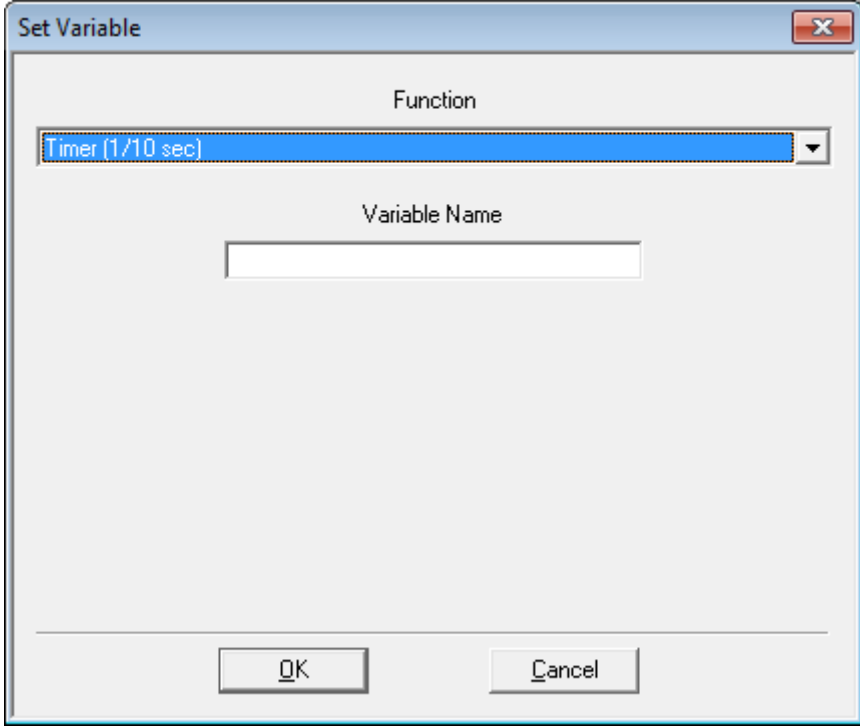

The operators in the list are summarized in this table.

Operators	
Arithmetic Operators	
+	Addition
*	Multiplication
-	Subtraction
/	Division
\	Floating Point Division
Algebraic Operators	
^	Power (raises the first argument to the power of the second argument).
MOD	Modulus (returns the remainder of the first argument divided by the second).
Logical (Boolean) Operators	
NOT	Not
AND	And
OR	Or
XOR	Exclusive or
EQV	Equivalent (Null or Boolean values only)
IMP	Implication (Null or Boolean values only)
The result of a logical operation is 1 (True), or 0 (False). Any operand with a non-zero value is considered true, while a zero value is considered false.	

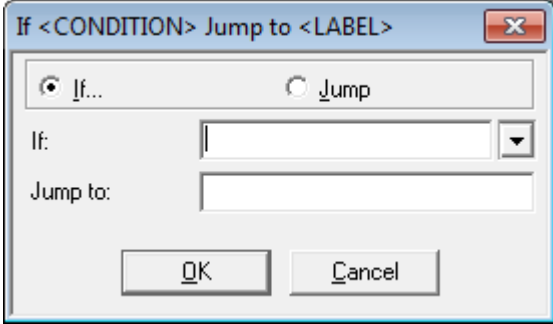
Set Variable Dialog Box			
Icon	Option	Level	Description
			<p>A value assigned using the SV command can be used for conditional jumping using the IF <Condition> Jump command. Actions can then be generated according to the variable value. The following example jumps the program cursor to a label if more than three seconds elapse after timer reset:</p> <pre>Reset Timer ... Set Variable TIME to timer IF TIME > 30 jump to PICKUP</pre> <p>For more information on variables, See section 7 Variable Programming, on page 75.</p>
	VT Set Variable to Timer	Pro	<p>Allows you to assign the current value of SCORBASE timer to a variable. The SCORBASE timer starts operating when SCORBASE is opened.</p>  <p>To initialize the SCORBASE timer in a program, use the Reset Timer (RT) command.</p>

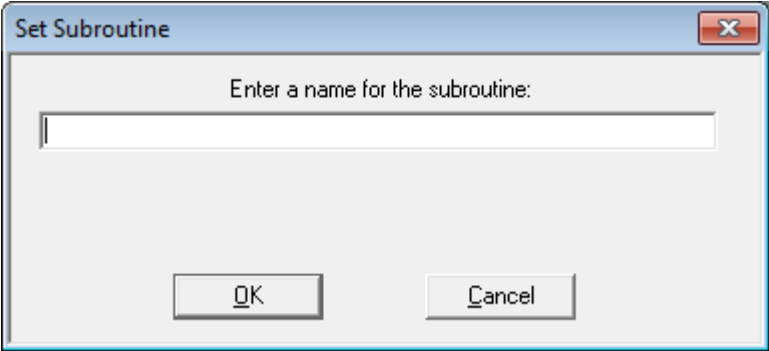
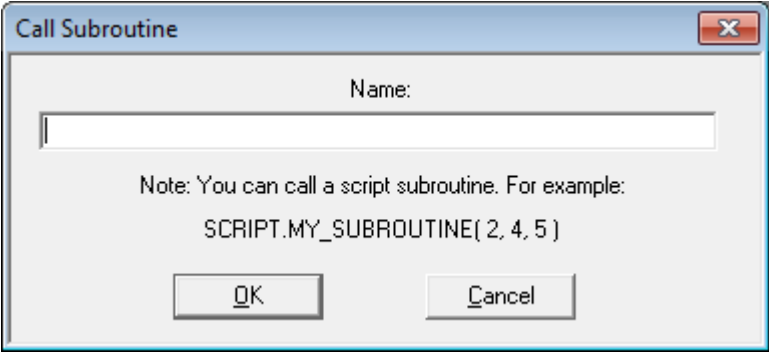
Set Variable Dialog Box			
Icon	Option	Level	Description
	IF If Jump to	2,Pro	<p>A conditional branch command, which is used to determine the program flow in relation to the value of the variables. The command opens this dialog box:</p>  <p>If the condition in the IF field is true, program execution jumps to the line specified by the label in the Jump to field.</p> <p>If the condition in the IF field is false, program execution skips to the following line.</p>
			<p>IF</p> <p>Enter the condition. The condition includes a variable name, a comparison operator and another variable name, or a number.</p> <p>Jump to</p> <p>Enter the name of a Label. (Be sure to include a line with this Label in your program.)</p>
			<p>Example:</p> <pre>If COUNTER > 0 jump to START_LOOP Go to Position 1 speed 5 ... START_LOOP: Go to Position 2 speed 5</pre> <p>If the value of Counter is greater than zero, the robot goes to Position #1.</p> <p>If the value of Counter is equal to or less than zero, the robot goes to Position #2.</p> <p>Use two equal signs (=) for equal operators. For example:</p> <pre>If COUNTER == 0 jump to END</pre> <p>The IF jump command can be converted to an unconditional jump command by selecting Jump (instead of If).</p>

Set Variable Dialog Box			
Icon	Option	Level	Description
	SS Set Subroutine	2,Pro	<p>Creates a subroutine. You can program up to 64 subroutines in one program. The command opens this dialog box:</p>  <p>Note: Create subroutines only at the end of the main program. Every subroutine must end with a Return from Subroutine command.</p>
	RS Return from Subroutine	2,Pro	<p>Marks the end of a subroutine. At run time, this command terminates the execution of the subroutine, and the program resumes execution at the line that follows the Call Subroutine command.</p> <p>Note: Every subroutine must end with a Return from Subroutine command.</p>
	CS Call Subroutine	2,Pro	<p>Activates the specified subroutine. The command opens this dialog box:</p>  <p>Notes:</p> <ul style="list-style-type: none"> • Use the Call Subroutine command either from the main program or from another subroutine command. • You can call the same subroutine repeatedly in the same program. • You can call a subroutine from a Visual Basic script that is loaded. Append the prefix <code>SCRIPT.</code> to the beginning of the Visual Basic subroutine name. If more than one VB script is loaded, it is the responsibility of the programmer to ensure that there is no conflict of names. • After the subroutine is executed, the program resumes execution from the line that follows the Call Subroutine command.

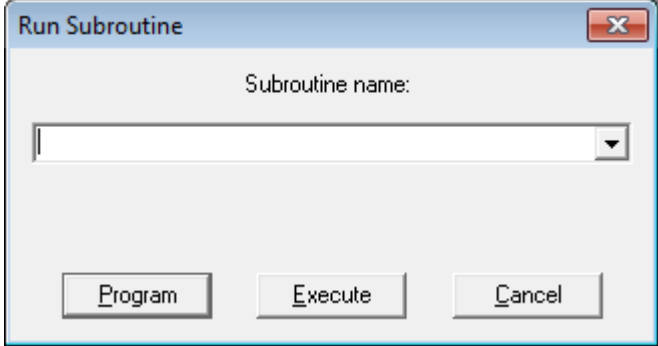
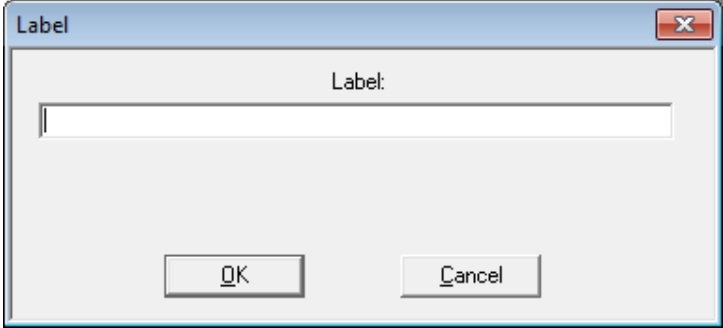
Set Variable Dialog Box			
Icon	Option	Level	Description
	RU Run Subroutine	Pro	<p>Activates the selected subroutine. The command opens this dialog box:</p>  <p>Either write a subroutine name, or select one from the drop down menu. To include the subroutine in the SCORBASE program, press the Program button. To run the subroutine, press the Execute button.</p> <p>When the command is initiated, execution of the main program continues, and the subroutine runs concurrently. SCORBASE facilitates the operation of up to 100 concurrent programs. (The Call subroutine command suspends the main program until the completion of the subroutine.)</p>
	LA Label	1,2,Pro	<p>Marks a line in the program that is referenced by a Jump command. The command opens this dialog box:</p>  <p>In the Label field, enter a name. Do not include blank spaces – use an underscore. Do not use the same label name more than once.</p>

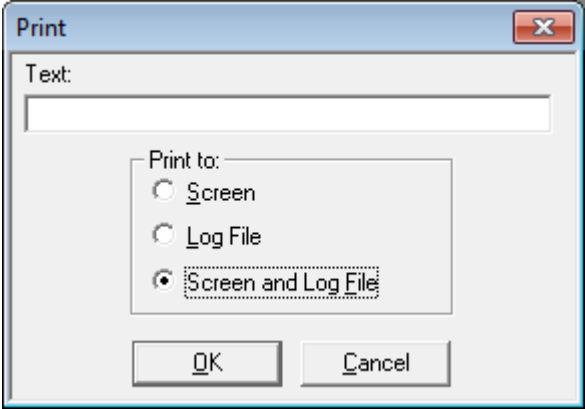
Set Variable Dialog Box			
Icon	Option	Level	Description
	PS Print to Screen & Log	2,Pro	<p>Instructs SCORBASE to print data containing strings, messages and variable values to a log file, or to the message window, or to both. The command opens this dialog box:</p>  <p>To print a value of a variable, place the variable name in single quote marks. For example: VARX='X' prints as VARX=50 (when the value of X is 50).</p> <p>To print a value of a Visual Basic Script variable, include "SCRIPT." followed by the variable name in single quote marks. For example: VARY='SCRIPT.Y' prints as VARY=100 (when the value of SCRIPT.Y is 100). Select the desired print destination.</p>

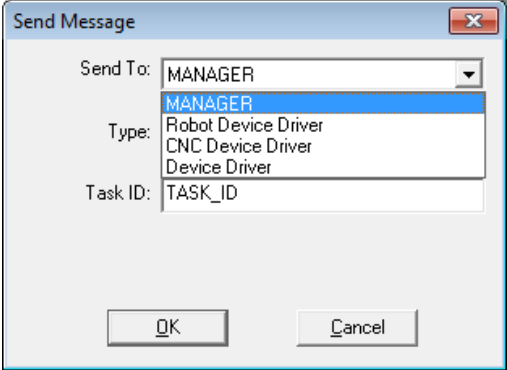
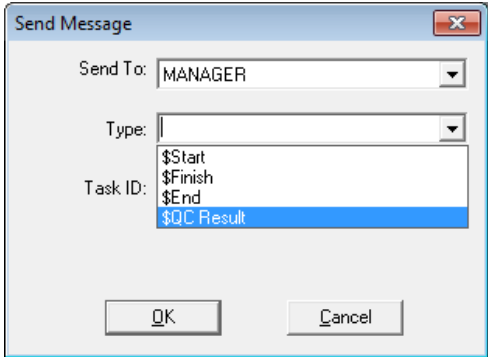
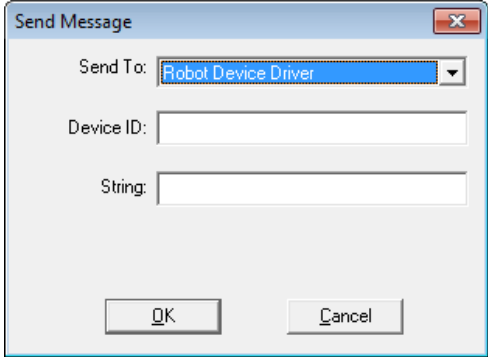
Set Variable Dialog Box			
Icon	Option	Level	Description
	SM Send Message	Pro	<p>Sends a message to MANAGER, Robot Device Driver, CNC Device Driver, or Device Driver.</p>  <p>For a message to the MANAGER, select the type of message from the list of available types. Type a Task ID, and select a message from the drop-down menu. Consult the Open CIM user manual for more details. The Send Message (Manager) dialog box is shown here.</p>  <p>For other device drivers, type the ID of the device you wish to receive the message, and enter the string to be sent. The Send Message (Robot Device Driver) dialog box is shown here.</p> 

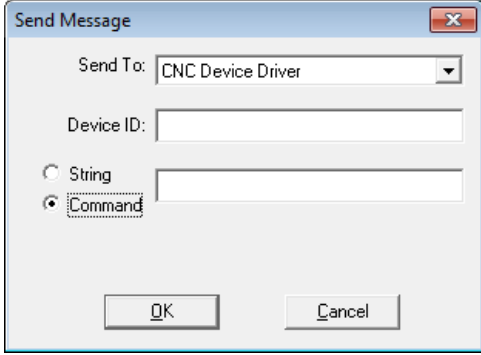
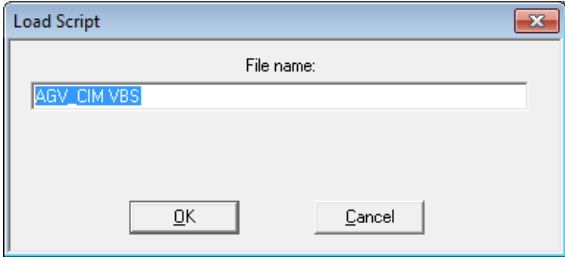
Set Variable Dialog Box			
Icon	Option	Level	Description
	MC Send Command	Pro	<p>Sends a command to the CNC Device Driver. This is the same dialog box as the SM command, except that the default device is the CNC Device Driver, and the default message is a command, rather than a string. Send Command (CNC Device) Dialog Box is shown here.</p>  <p>Enter the device ID and the command in the boxes.</p>
	LS Load Script	Pro	<p>Loads a Visual Basic script by means of the following dialog box:</p>  <p>The script must be located in the same subdirectory as the SCORBASE project file. You must be sure that the LS command is actually executed before you attempt to call any of the affected subroutines or variables.</p> <p>You may load more than one script into a single SCORBASE project. However, it is the programmer's responsibility to ensure that there are no name conflicts.</p>
	EN End Program	Pro	<p>This command enters the command End on the selected line of the program. It signifies the end of the program. It may be used in more than one subroutine, such as subroutines which respond to various error conditions.</p>

6.6. INPUT/OUTPUT COMMANDS

Inputs & Outputs Branch Command Tree		
Level 1 – Introductory	Level 2 – Advanced	Pro – Professional

Input and Output Command			
Icon	Option	Level	Description
	If Input # On/Off Jump	1,2,Pro	<p>Causes the program to jump to a label or call a subroutine, if the state of the tested digital input matches the status specified (On or Off). The command opens this dialog box:</p> <p>In the Input Number field, enter the number of digital input (1-8), or a variable.</p>

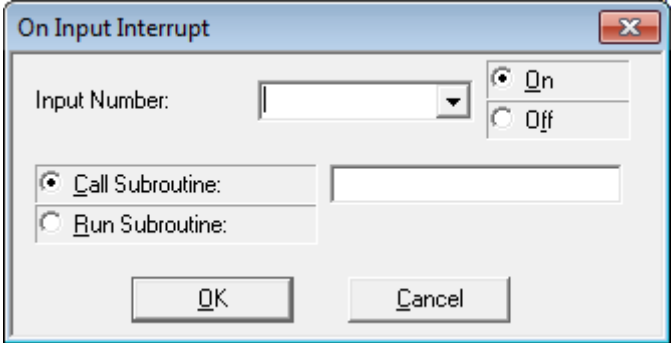
OI On Input Interrupt # On/Off	Pro	<p>Sets the condition for an input interrupt service. The service (Call Subroutine or Run Subroutine) is performed whenever the condition (input status) is satisfied, regardless of the current program pointer position. The command opens this dialog box:</p> 
		<p>Input Number</p> <p>Enter the number of a digital input, a variable or the word ANY. Use of the word ANY causes any input (1-8) to evoke the interrupt state.</p> <p>On/Off</p> <p>Select the state of the input.</p> <p>Call Subroutine</p> <p>Enter the name of a subroutine that is executed in case of interrupt. Execution of the main program is suspended until completion of the subroutine.</p> <p>Run Subroutine</p> <p>Enter the name of a subroutine that is executed in case of interrupt. Execution of the main program continues, and the subroutine is spawned as a concurrent process.</p>

An interrupt command causes the program to halt the command it is currently executing (which can also be a movement or a delay), and to immediately execute the command specified for this interrupt. If the specified command is a Call Subroutine, the program resumes from the point where it was suspended, as soon as the subroutine completes its execution. If the specified command is a Run Subroutine, the main program resumes immediately after the concurrent process is started.

An interrupt command can be disabled and enabled by means of the EI (Enable Interrupt) and DI (Disable Interrupt) commands described below.

For Example:

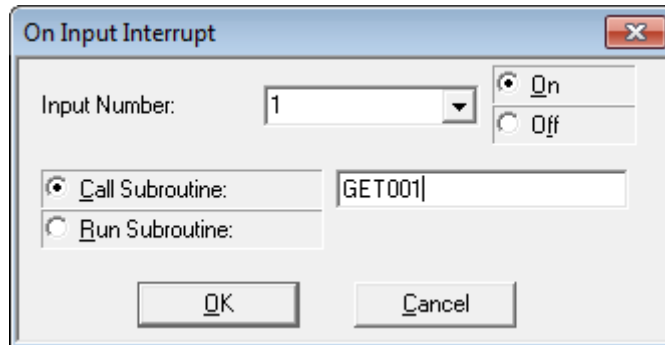



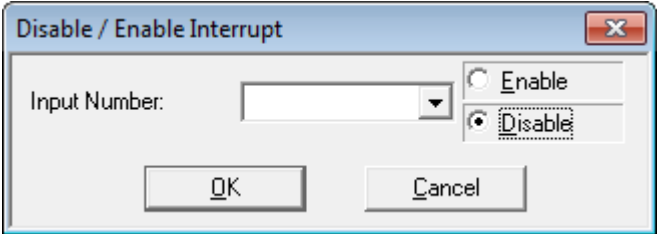

This inserts the following line of code:

```
On input interrupt 1 on call subroutine GET001
```

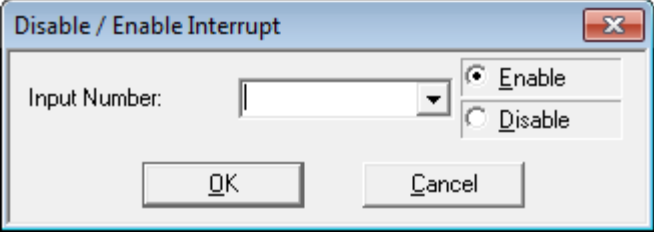
When Input 1 is turned on, the program immediately calls subroutine GET001. If any axes are moving when the interrupt occurs, they immediately stop. When the subroutine is completed (Return from Subroutine command is reached), the axes reassume the position and status that were interrupted, and the program continues from that point.

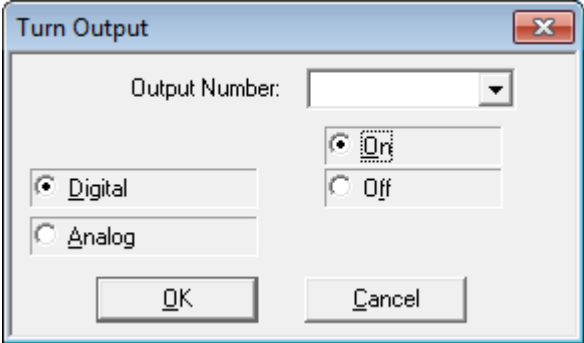
Interrupt Commands			
Icon	Option	Level	Description
	DI Disable Interrupt #	Pro	<p>Causes the specified input interrupt to become inactive. When an interrupt is inactive, it is disregarded until the EI (Enable Interrupt) command reactivates it. The command opens this dialog box:</p>  <p>Input Number Enter an input number, a variable, or the word ALL.</p> <p>Enable/Disable Select Enable in order to modify the command.</p>

Interrupt Commands			
Icon	Option	Level	Description
	EI Enable Interrupt #	Pro	<p>Causes the specified input interrupt to become active. The command opens this dialog box:</p>  <p>When an interrupt is active, it is waiting for an interrupt status (defined using the OI [On Interrupt] command described above).</p> <p>Input Number Enter an input number, a variable, or the word ALL.</p> <p>Enable/Disable Select Disable in order to modify the command.</p>
	ON Turn On Output #	1,2,Pro	<p>Sets the state of the specified digital output On. The command opens this dialog box:</p>  <p>Output Number Select a number or type a variable name. The default settings of Digital and On can be changed.</p>

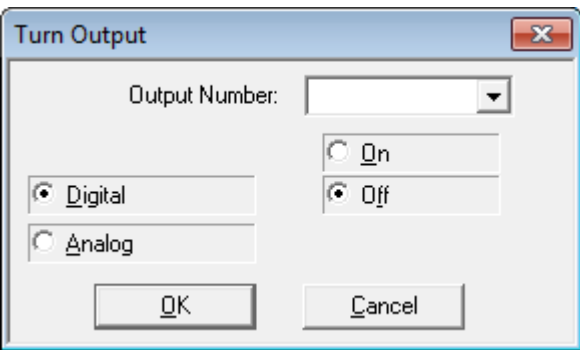
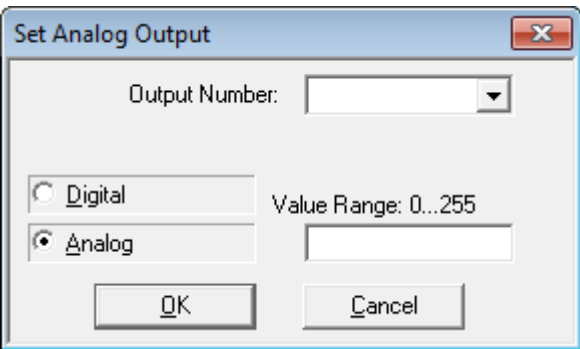
Interrupt Commands			
Icon	Option	Level	Description
	OF Turn Off Output #	1,2,Pro	<p>Sets the state of the specified digital output Off. The command opens this dialog box:</p>  <p>Output Number Select a number or type a variable name. The default settings of Digital and Off can be changed.</p>
	AO Set Analog Output #	Pro	<p>Sets the state of the specified analog output. The command opens this dialog box:</p>  <p>Output Number Enter a number (1 or 2), or a variable.</p> <p>Value Range Enter a number between 0 and 255 which corresponds to the output voltage. The range of the output voltage is 0-10 Volts. The Analog default setting can be changed.</p>

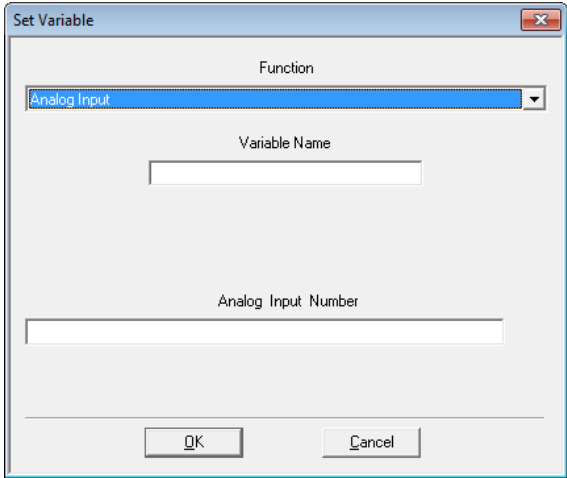
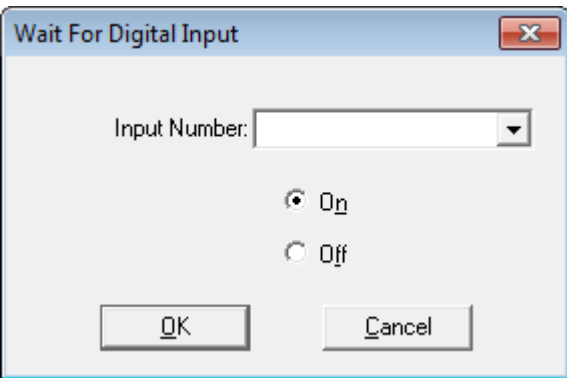
Interrupt Commands			
Icon	Option	Level	Description
	AI Set Variable to Analog Input #	Pro	<p>Sets the value of the specified analog input to a variable. The command opens this dialog box:</p>  <p>Variable Name Enter the name of the variable. The first character of the name must be a letter.</p> <p>Analog Input Number Enter an input number (1-4) or a variable, where the variable value is an integer in the range of 0-255 corresponding to a controller input voltage of 0-10 volts.</p> <p>See also the description of the Set Variable commands in the preceding sections of this chapter.</p>
	WN Wait For Digital Input # On		<p>Halts program execution until the selected input is switched on. The command opens this dialog box:</p> 

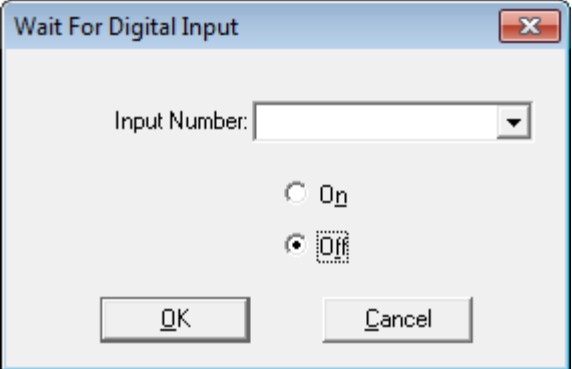
Interrupt Commands			
Icon	Option	Level	Description
	WN Wait For Digital Input # Off		<p>Halts program execution until the selected input is switched off. The command opens this dialog box:</p> 

6.7. ADVANCED COMMANDS

Advanced Commands are displayed in the Command Tree when you select **Options | Advanced Options | Advanced Commands**. The Advanced Commands command tree for the professional level is shown here:

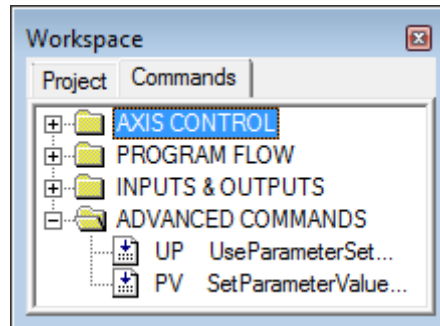

The Advanced Commands are summarized in this table.

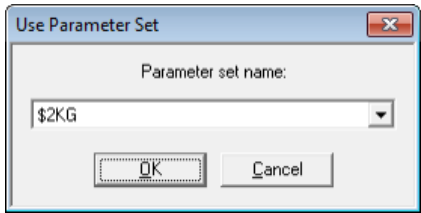
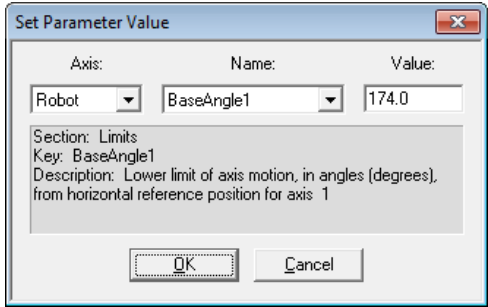
Advanced Commands		
Command	Level	Description
UP Use Parameter Set	Pro	<p>Specifies the Parameter Set to be used. The command opens this dialog box:</p>  <p>Open the drop-down list to select the desired Parameter Set and click OK.</p> <p>See 10.2.2 Parameter Set Window on page 94 for further information.</p>
PV Set Parameter Value	Pro	<p>Sets the value for a selected device parameter by name. The command opens this dialog box:</p>  <p>Axis Open the drop-down list to select the axis for which you need to change the parameter.</p> <p>Name Open the drop-down list to select the parameter whose value needs to be changed.</p> <p>Value Enter the new value.</p> <p>The details of the selected parameter are automatically displayed.</p>

6.8. VISION COMMANDS

Vision Commands are displayed in the Command Tree when you select **Options | Advanced Options | ViewFlex Commands**. See the ViewFlex User Manual for full details.

The Vision Commands command tree for the professional level is shown here:

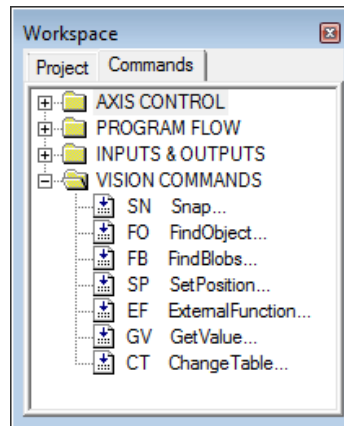

7. Variable Programming

The SCORBASE language allows variable programming. Variables allow you to write commands that change as the state of the robot or its environment changes during program execution. Therefore they are useful for creating loops and subroutines in robot programs.

To use a variable, it must first be defined using the **Set Variable to Computation** command. Variable names can be up to 22 characters long. It is recommended, however, that you use meaningful names that are as short as possible. The first character of the name must be alphabetic.

SCORBASE has full access to variables in Visual Basic scripts that are loaded in memory. The variable name must begin with **SCRIPT.**, for example: **SCRIPT.A**. Values can be transferred both to and from variables in external Visual Basic scripts.

In most editing commands, a variable can be specified instead of a numeric value.

A variable cannot be used to specify a Label or a Subroutine.

If at run time the program encounters a variable whose value is not defined or is out of range, an error message is displayed.

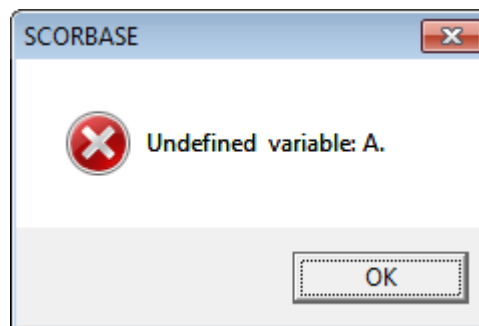

7.1. USING A VARIABLE INSTEAD OF A NUMERIC VALUE:

Example #1

```
Set Variable station1=5
Set Variable lamp=1
Go to Position station1 fast
Turn on output lamp
```

In this example, one of the robot stations named “*station1*” is recorded as position #5 and a lamp is connected to output #1. When the program initiates, the value (5) is assigned to the variable named *station1* and the value (1) is assigned to the variable *lamp*. The following program lines send the robot to position “*station1*” and turn on a “*lamp*”. Using a meaningful name for the variable makes the programming, debugging and maintenance easier.

Example #2

```
Set variable pos = 0
Start:
Set variable pos = pos +1
```



```
Go to position pos fast
Wait 50 (10ths of seconds)
If pos < 5 jump to start
```

In this example, the robot moves to Positions #1, #2, #3, #4 and #5. At each position, the robot waits 50 seconds. After waiting at position #5, the program terminates.

Example #3

```
Start:
Set variable tested = 0

Loop:
Set variable tested = tested +1
If input tested off call sub off
If input tested on call sub on
If tested < 8 jump to loop
Jump to start

Set Subroutine off
Turn off output tested
Return from subroutine.

Set Subroutine on
Turn on output tested
Return from subroutine
```

In this example, the program sequentially scans digital inputs 1 through 8 in an endless loop.

If the tested input is *On*, the program turns **on** the corresponding output.

If the tested input is *Off*, the program turns the corresponding output **off**.

7.2. MONITORING VARIABLE VALUE

To monitor a variable value, SCORBASE offers the following tools:

1. When SCORBASE is running and a **Set Variable** command is executed, the current value of the variable is displayed in the status line at the bottom of the screen.
2. When the program is *not* running, click the **Set Variable** command in which the value is assigned to the variable, and then execute this line using the Run Single Line command. The variable value is displayed in the status line at the bottom of the screen.
3. The **Print to Screen & Log (PS)** command can also be used to print the actual value of a variable, by placing the variable name within single quote marks in the text to be printed.

For example:

```
Set Variable z = 5  
Set Variable x = 9  
Set Variable y = x - z  
Print to screen z='z' x='x' y='y'
```

When the program is running, the following messages are displayed in the status bar:

1. When the first line is executed, the message is z=5.
2. When the second line is executed, the message is x=9.
3. When the third line is executed, the message is y=4.
4. When the fourth line is executed, this window is displayed:

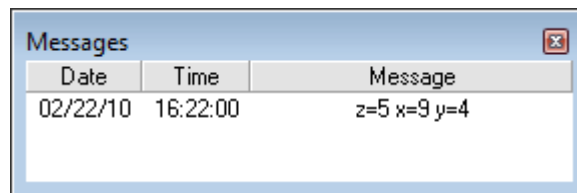

A screenshot of a 'Messages' window with a table containing one row of data. The window has a title bar with the text 'Messages' and a close button. The table has three columns: 'Date', 'Time', and 'Message'. The data row shows the date '02/22/10', the time '16:22:00', and the message 'z=5 x=9 y=4'.

Date	Time	Message
02/22/10	16:22:00	z=5 x=9 y=4

8. Program Execution

The Program window and the dialog bars described in this chapter are used for activating and monitoring program execution.



Select **Window | Run Screen** to display only the Program window, which shows the section of the program currently executed.

- Status Bar - indicates the currently executed line or current value of a variable.
- Inputs and Outputs Dialog Bars - show the Analog Input, Analog Output, Digital Input, Digital Output values. To activate the dialog bars that are most useful for program execution, select **View | Dialog Bars** and then the desired dialog bar from the pop-up menu.
- Log file - records data during program execution.

8.1. RUNNING A PROGRAM

SCORBASE offers three modes of running a program. To select the running mode do one of the following:

- Click the appropriate Run icon in the toolbar.
- Select one of the Run options in the Run Menu.
- Press the function key.

Running a Program Options		
Icon	Option (Shortcut)	Description
	Single line (F6)	Runs the currently selected (highlighted) line
	Single cycle (F7)	Runs the program from the currently selected (highlighted) line. Running stops after the last line is executed
	Continuous (F8)	Runs the program from the currently selected (highlighted) line. After the last line is executed, program execution continues from the first line

Note:



- The [Run] key on the Teach pendant cannot be used to start execution of SCORBASE programs.
- Always restart execution of a program from the first line after you have changed program data (e.g., recorded new coordinates for a position, edited a program line, etc.).

8.2. HALTING PROGRAM EXECUTION

Stop and Pause are the two methods of halting program execution in SCORBASE.

To stop or pause programs from SCORBASE perform one of the following:

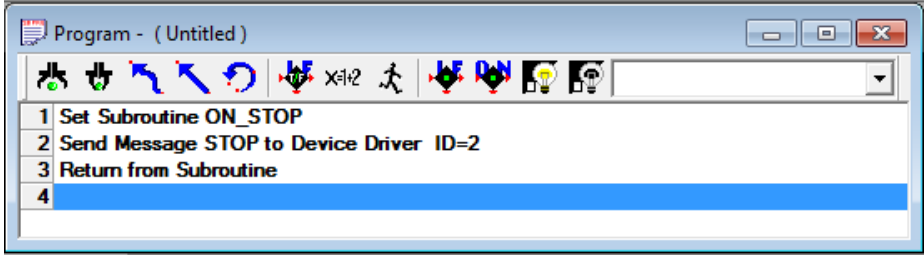
- Click the appropriate icon in the toolbar.
- Select **Run | Stop**, or **Run | Pause**.
- Press **F9 / F10**. Make sure the SCORBASE application is the currently active window before you press **F9 (STOP)** or **F10 (PAUSE)**.
- To stop the program, you can also press the red **EMERGENCY** button on the controller or press the **ABORT** key on the Teach Pendant (if installed).

Halting the Program		
Icon	Option (Shortcut)	Description
	Stop (F9)	<p>Program execution is stopped immediately. Use this command only in emergencies.</p> <p>If the workstation is connected only to a stationary robot such as an ER-4u, the STOP command is sent directly to the device. However, other devices such as the ER-400 AGV Mobile Robot require the user to define a subroutine with the name ON_STOP. When the STOP button or F9 is pushed, the ON_STOP subroutine is called.</p> <p>The subroutine might contain a line such as Turn Off Output 1. Here is an example for use with the ER-400 AGV Mobile Robot:</p> 
	Pause (F10)	Stops program execution only after the current command has been executed. Thus, axes may continue moving (to complete their motion) after the Pause command is issued.

8.3. INPUTS AND OUTPUTS DIALOG BARS

8.3.1. Digital Inputs & Outputs Dialog Bars

The Digital Inputs & Outputs dialog bars show the status of the controller digital inputs and outputs. The display is available in all modes of operation. The Digital Input Dialog Bar is shown here:

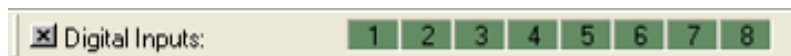

The Digital Output Dialog Bar is shown here:

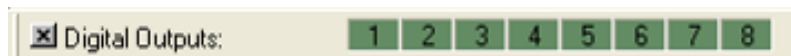

In both dialog bars, when the I/O status is *Off* (false), the matching I/O number is dark green. When the I/O status is *On* (true), the matching I/O number is light green

If control is On, the sixteen Output / Input LEDs on the front panel reflect the I/O status.

If control is On, clicking on an output number in the Digital Output dialog bar toggles the status of the controller's digital outputs.

In *Off-Line* the Digital Output dialog bar can also be used to simulate the status of controller's digital inputs. This option is useful for checking the **If Input#_onJump** command.

In On-Line mode, to test the program response for the **If Input#_onJump** command, short the designated input terminal to the digital input ground.

8.3.2. Analog Inputs & Outputs Dialog Bars

SCORBASE can monitor and control four (4) analog inputs and two (2) analog outputs. The Analog Inputs & Outputs dialog bars show the values of the controller Analog Inputs and Outputs. These dialog bars may also be opened or closed using the **View | Show All Dialog Bars** or **View | Close All Dialog Bars** commands. The Analog Input dialog bar is shown here:

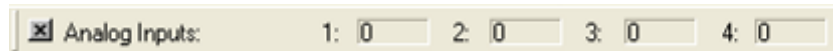

The Analog Output dialog bar is shown here:



The Analog Inputs and Output resolution is 8-bit. The Analog Input / Output range is from 0 (minimum) to 255 (maximum).

Output values can only be manipulated when SCORBASE is operating On-Line. To change the value of an Analog Output, perform one of the following:

- Click **Output** (the color turn from light yellow to white), and type a number.
- Use the AO Set Analog Output # command.

When the controller receives an Analog Input signal from an external device, the value (0-255) of the signal is reflected in the **Input Value** field.

8.4. SCORBASE LOG FILE

The SCORBASE log file records the messages printed using the **PS (Print to Screen Log)** command. To print to a message to the log file, click either **Log File** or **Screen and Log File**.

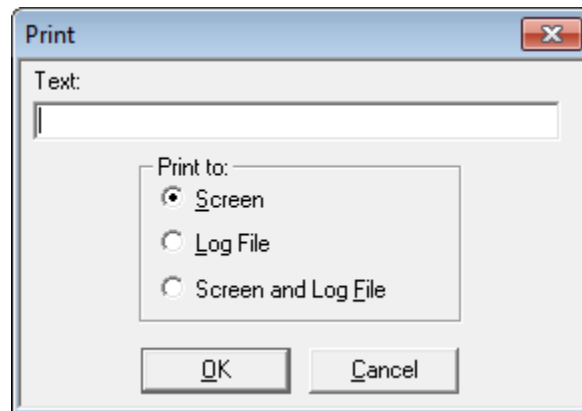

The Log file is initialized (cleared) each time SCORBASE is loaded.

To see the file content, open the file SCBS.LOG using a text editor (such as WordPad). The file is located in the SCORBASE subdirectory named BIN.

SCORBASE generates a SCBS.BAK backup file of the SCBS.LOG file each time the program is closed.

9. Project Files Management

A SCORBASE project includes the following files:

- SCORBASE program (file extension *.SBP)
- Recorded Position files (file extension *.PNT)
- Project data (file extension *.WS)
- Graphic image (if RoboCell is installed – file extension *.3DC).



All commands (except for Open) relate only to the SBP, PNT and WS files.

Opening or saving a project from the File menu opens or saves all project files (three or four files).

As default, all files are located in the Projects directory (folder) in the ER 2u or ER 4u directory (depending on which robot is being used for the project).

9.1. PROJECT MANAGEMENT

SCORBASE project files are managed by means of the standard Windows file tools, which can be accessed by icons or via the File menu.

Project Management Options		
Icon	Option (Shortcut)	Description
	New (Ctrl+N)	Opens a new, untitled, project. All project-related files are created.
	Open (Ctrl+O)	Opens a Load Project File dialog box for opening a previously saved project. All project-related files are opened. Only one project may be open at a time.
	Save (Ctrl+S)	Saves the currently active project. If the project has not previously been saved (i.e., is untitled), a dialog box for specifying the project name opens. All project-related files are saved, including Program, Positions and Graphics.
	Save As...	Opens the Save Project dialog box for saving the currently active project under a new name. All project-related files are saved under that new name. As default, all projects are saved in a Projects folder.
	Close Project	Closes the currently open project.
	New Script	Opens Notepad. The user can then begin to write a new Visual Basic script file.
	Open Script	Opens File Selector box for opening an existing Visual Basic script file.

Project Management Options		
Icon	Option (Shortcut)	Description
	Print Program	Prints the program The Program window must be active to select this option
	Print Positions	Prints the position table The Position window must be open and active to select this option. You can open the Position window by selecting View Positions.
	Print 3D image	Prints the 3D image (if RoboCell program is installed).
	Print Preview 3D Image	Opens a dialog window that shows how the printed cell is displayed on paper.
	Print Charts	Opens a dialog box to select the specific axis chart for display or printout. Only one axis can be selected at a time.
	Print Preview Charts	Opens a screen which displays the selected axis chart before printout showing how the printed cell is displayed on paper.
	Import 3D Model	Opens the Import 3D Image dialog window showing the graphic module files (*.3DC files).
	Edit 3D Model	Opens the Graphic Module in CellSetup.
	View File	Opens the View File window to display the program or position of any selected project.
	Exit	Quits SCORBASE. If changes to a program or position file have been made, but not yet saved, a warning message is displayed.

10. System Configuration

SCORBASE offers the following options for system configuration:

- Window Layout options
- Experience level
- Hardware setup

10.1. WINDOW LAYOUT OPTIONS

The window layout options are accessible from the Window menu, shown below.

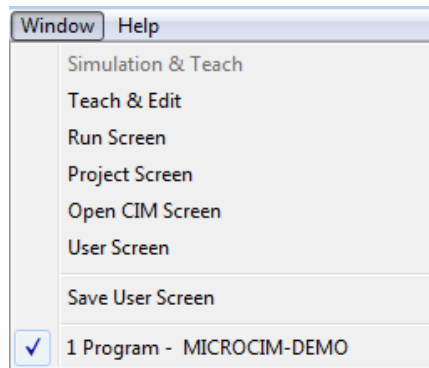

The display options enable optimal usage of the screen area. SCORBASE offers five basic display options and a wide range of dialog bars and windows through which the user can see and change system data.

10.1.1. Simulation & Teach

The Simulation and Teach layout is shown here:

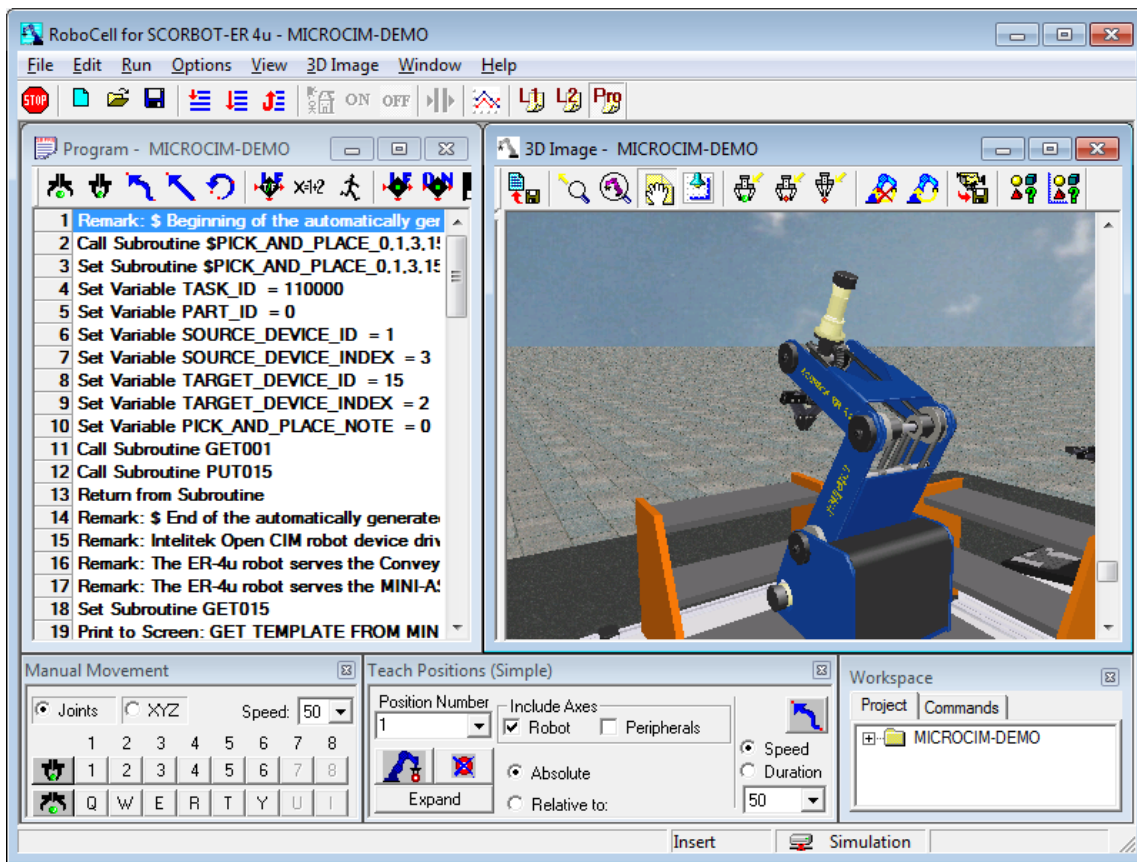

Available only if RoboCell is installed, this layout option displays the following windows:

- Program Window that holds the SCORBASE program.
- 3D Image
- Manual Movement Dialog Box
- Teach Positions Dialog Box
- Workspace Window that shows:
 - Project tab
 - Commands tab

For further information, see the RoboCell User Manual.

10.1.2. Teach & Edit

The Simulation and Teach layout is shown here:

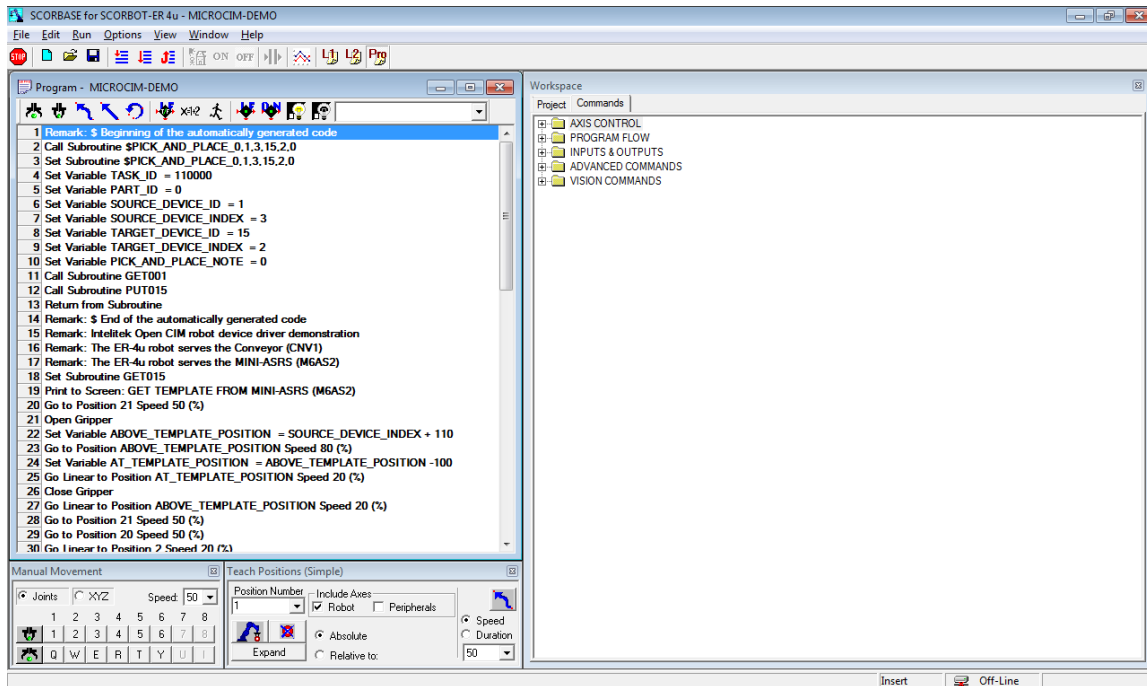

When a SCORBASE project is opened, the screen is set for the Teach & Edit display mode by default. In this mode, these windows and dialog boxes are displayed:

- Program Window that holds the SCORBASE program
- Manual Movement Dialog Box
- Teach Positions Dialog Box
- Workspace Window that shows:
 - Project tab
 - Commands tab

To open the Teach & Edit layout, select **Window | Teach & Edit**.

10.1.3. Run Screen

The Run Screen layout is shown here:

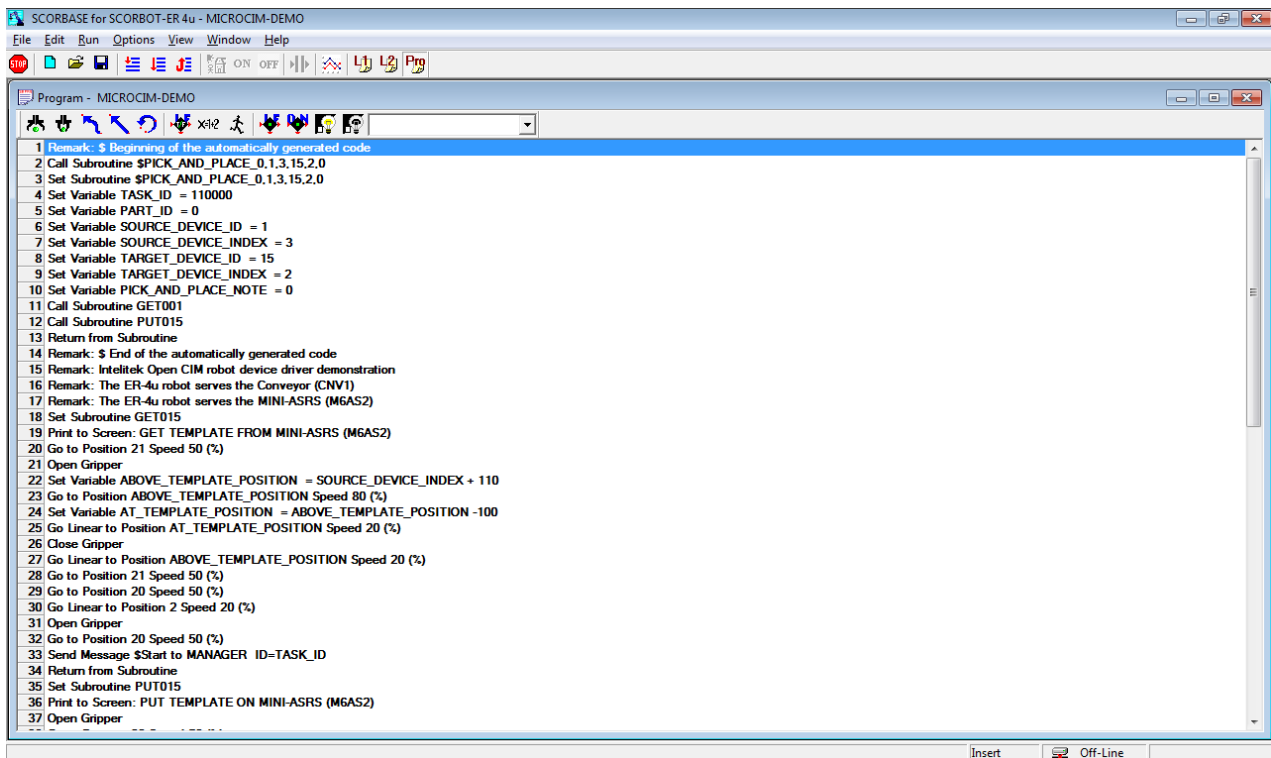

The Run Screen display option opens the Program Window only. When the program is running, the currently executed line is highlighted and information on the currently executed command is displayed in the status bar.

To open the Run Screen layout, select **Window | Run Screen**.

10.1.4. Project Screen

The Project Screen layout is shown here:

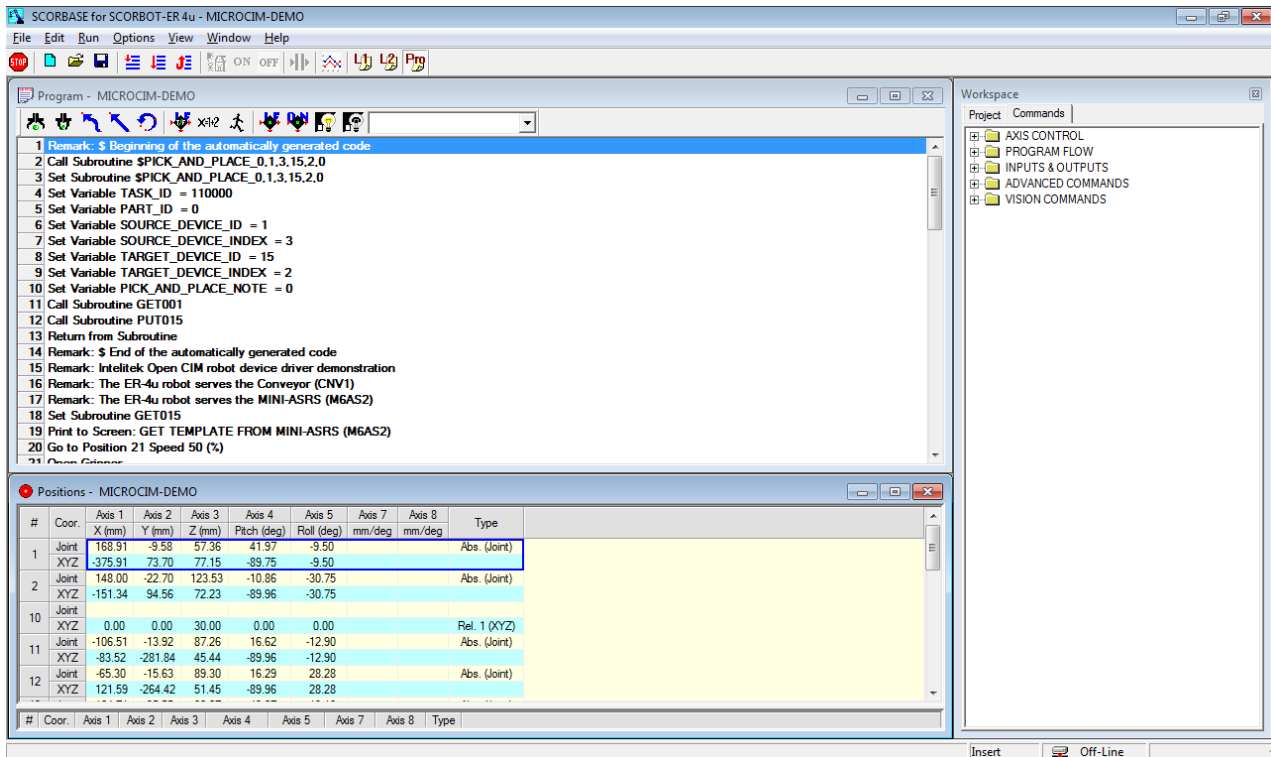

The Project Screen option displays the following:

- Program Window that holds the SCORBASE program
- Workspace Window that shows:
 - Project tab
 - Commands tab
 - Positions Window

When the program is running, the currently executed line is highlighted, and information on the currently executed command is displayed in the status bar.



To open the Project Screen layout, select **Window | Project Screen**.

10.1.5. Open CIM Screen

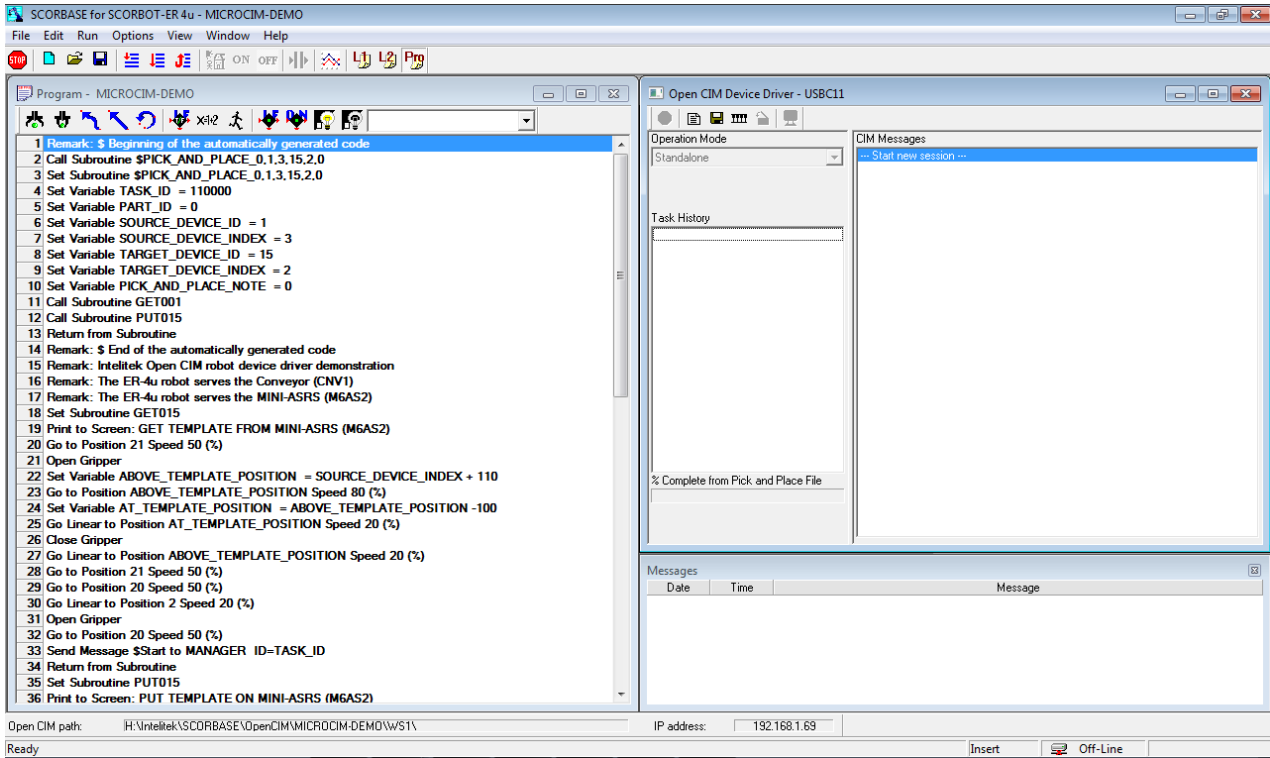
The Open CIM Screen layout is shown here:



The Open CIM Screen option displays the following:

- Program Window that holds the SCORBASE program
- Open CIM Device Driver Window, which provides:
 - Toolbar, with  button for Manual Stop
 - Operation Mode selector
 - Online
 - Simulation
 - Standalone. When this option is selected, you may press the  icon on the toolbar to open the TCP/IP dialog box for establishing communications with other Open CIM applications.

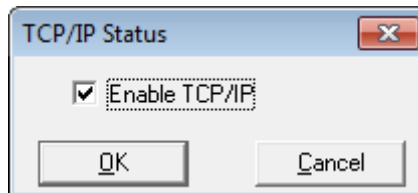

- Task History panel

- Percentage Complete from Pick & Place File
- CIM Messages panel
- Messages Window

To use the Open CIM Screen layout, select **Window | Open CIM Screen**.

10.1.6. User Screen; Save User Screen

The User Screen and Save User Screen options can be seen in the Window menu here:

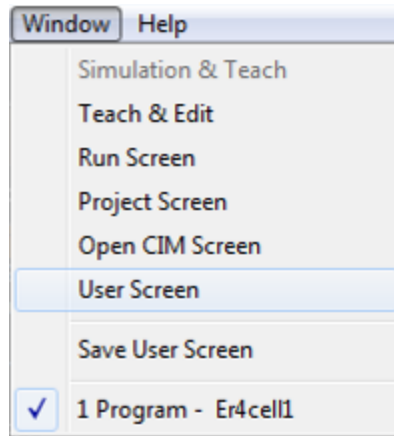

By default, the User Screen displays the same windows as the Teach & Edit Screen. However, the user can customize the layout of the windows to the needs of the project. This is useful when you have specified one or more dialog bars under the View menu.

To save the layout for future use, select **Window | Save User Screen**.

Whenever you desire to use that layout again, select **Window | User Screen**.

10.2. OPTIONS MENU

The following section covers additional Options menu functions. The Options menu is shown here:

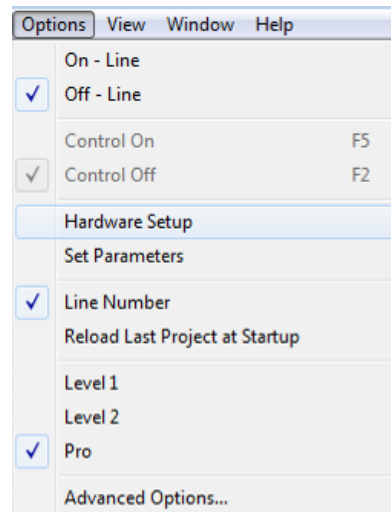

10.2.1. Hardware Setup

SCORBASE allows you to define the devices that are connected and operated by the controller as Axes 7 and 8. The following peripherals can be connected to the USB Controller:

USB Controller Peripherals	
Catalog number	Description
1009	Rotary Table, 24V
1010	Conveyor Belt (gray), 24V
1020	1.0m Linear Slidebase, belt-drive, 24V
1021	1.8m Linear Slidebase, belt-drive, 24V
1013	Linear Table 0.3m, 24V
1014	XY-Table, 24V
1234	Motor Kit 24V

Note: The following peripherals are not supported:

- 1.0m Linear Slidebase, belt-drive, 24V, Catalog #1018
- 1.8m Linear Slidebase, belt-drive, 24V, Catalog #1019

Contact your local distributor for further information.

Do not change the hardware setup unless you are authorized to do so. To define the devices, select **Options | Hardware Setup**. The Hardware Setup dialog box opens (shown below). Click the arrow to open the list of available devices, and then click the desired device.

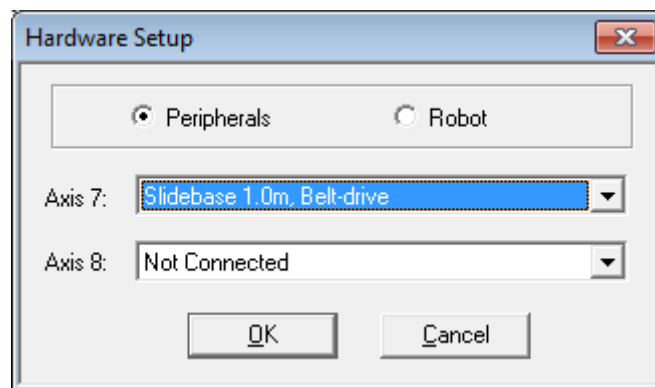

The Hardware Setup Peripherals Dialog Box showing default settings is shown here:

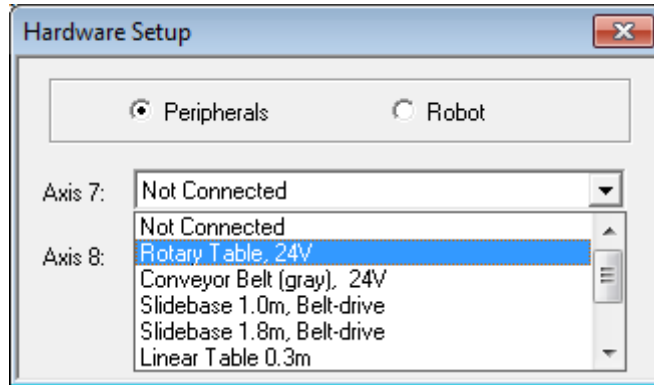

The **Hardware Setup** option also enables you to work with a different robot from the one you selected during installation. To do so, click the **Robot** radio button.

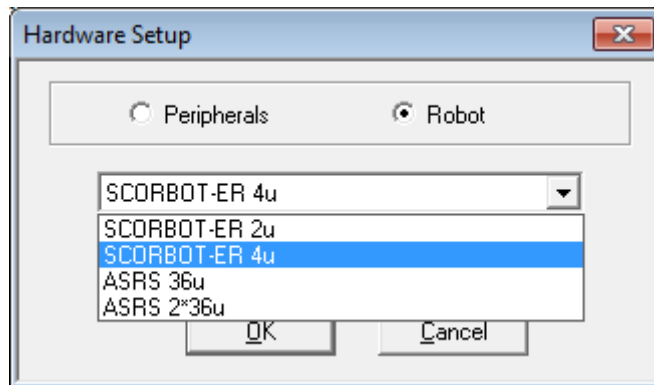

Select the desired robot and click **OK**.

10.2.2. Parameter Set Window

The Parameter Set Window - for Robot is shown here:

Description	Value
Lower limit of axis motion, in angles (degrees), from horizontal reference position for axis 1	174.0
Upper limit of axis motion, in angles (degrees), from horizontal reference position for axis 1	-132.0
Lower limit of axis motion, in angles (degrees), from horizontal reference position for axis 2	31.0
Upper limit of axis motion, in angles (degrees), from horizontal reference position for axis 2	-124.0
Lower limit of axis motion, in angles (degrees), from horizontal reference position for axis 3	4
Upper limit of axis motion, in angles (degrees), from horizontal reference position for axis 3	-115.0
Lower limit of axis motion, in angles (degrees), from horizontal reference position for axis 4	115.0
Upper limit of axis motion, in angles (degrees), from horizontal reference position for axis 4	-113.0
Lower limit of axis motion, in angles (degrees), from horizontal reference position for axis 5	570
Upper limit of axis motion, in angles (degrees), from horizontal reference position for axis 5	-570
Lower limit of working envelope radius, in meters	0.05
Upper limit of working envelope radius, in meters	0.940
Lower limit of Z coordinate, in meters	-0.109
Upper limit of Z coordinate, in meters	0.940
Minimum elbow angle, in degrees	5
Z coordinate of the rotation axis of arm link 2 when robot at home position, in meters	0.349
X coordinate of the rotation axis of arm link 2 when the robot at home position, in meters	0.016
Length of arm link 2 from the first articulated joint, in meters	0.221
Y coordinate (offset from center along the Y-axis) of the TCP when robot at home position, in meters	0
Length of arm link 3 from the second articulated joint, in meters	0.221
Distance from pitch axis to tip of gripper, in meters	0.145
First robot axis for homing	2
Second robot axis for homing	3
Third robot axis for homing	5
Fourth robot axis for homing	4
Fifth robot axis for homing	1
Sixth robot axis for homing	6

The Parameter Set Window - for Axes is shown here.

Description	Value
Axis type bitmap; bit mask: 0=rotational, 1=linear, 2=gripper, 4=unlimited axis	0
Maximum position error for impact detection, in encoder counts	70
Lower limit of axis motion, in encoder counts	-25000
Upper limit of axis motion, in encoder counts	20000
Maximum speed setting, in units of encoder counts/(second)	6500
Maximum acceleration/deceleration allowed for each axis during movement; in units of encoder counts/(second) ²	11000
Speed setting for manual movement in one direction.	160
Speed setting for manual movement in opposite direction.	-160
Number of encoder counts for 90 degrees; when axis is linear, value is number of encoder counts for 90 mm	10216
Encoder count at horizontal reference position	-10786
Proportional feedback constant	120000
Differential feedback constant	1200000
Integral feedback constant	12000
Velocity feed forward constant	0
Zero offset bias	0
Homing Velocity	100
Maximum encoder counts for impact detection during homing	2
Number of ticks [24 ms] for impact detection during homing	10
Maximum time for homing, in milliseconds	90000
Maximum movement during homing, in encoder counts	10000
Offset after home switch found, in encoder counts	45

SCORBASE contains the following parameter sets:

SCORBASE Parameter Sets	
Parameter Set	Description

\$2KG	Moves objects that weigh about 2 kg.
\$3KG	Moves objects that weigh about 3 kg.
\$Current	Current parameter set loaded to the controller.
\$Default	Default set when parameters are optimized.
Maxspeed	Activates the robot at maximum speed.

To modify any of the parameters of the above vendor-supplied sets you must save the set under a different name. To do so:

1. Click the Save As icon to open the dialog box.
2. Enter the name of the new Parameter Set
3. Click **OK** to save.

The Parameter Set Window toolbar is shown here:

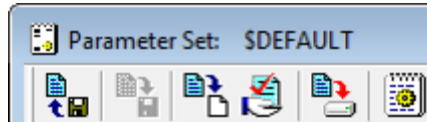

Use the Parameter Set Window toolbar to select one of the following options:

Parameter Set Window Toolbar Options		
Icon	Option	Description
	Open	Displays the Open Parameter Set window. Select the desired Parameter Set from the list.
	Save	Saves the Parameter Set after changes have been affected. A Parameter Set marked with the \$ symbol cannot be changed and saved. The set must first be saved under a new name using the Save As icon.
	Save As	Opens the Save Parameters Set As dialog box. Enter the name of the new Parameter Set and click OK to save it.
	Default	Displays the \$Default Parameter Set.
	Apply	Loads the selected Parameter Set to the controller.
	View	Opens the selected Parameter Set Window, which lists all the parameter keys, with description and value, included in the Parameter Set. The keys are listed by sections.

10.2.3. Line Number

The Line Number option is shown in the Options Menu, below.

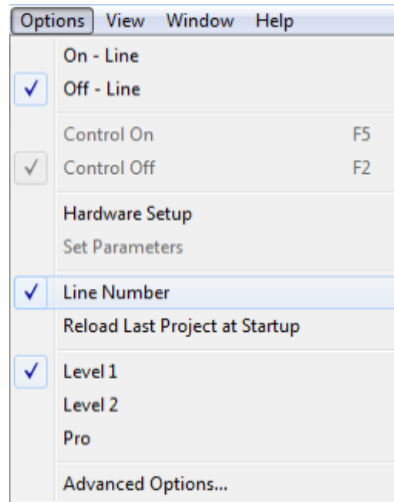

By default, SCORBASE displays program line numbers in the Program Window. If you wish to hide them, uncheck the toggle under **Options | Line Number**.

10.2.4. Reload Last Project at Startup

The Reload Last Project at Startup option is shown in the Options Menu, below.

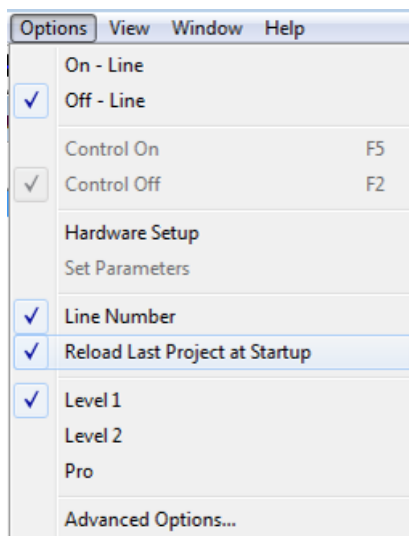



When SCORBASE is initiated, the program can be set up to automatically open the last project. To toggle this option, select or deselect **Options | Reload Last Project at Startup**. A checkmark next to this option indicates that the option is on.

10.2.5. Experience Level

SCORBASE offers three experience levels:

- Introductory (Level 1)
- Advanced (Level 2)
- Professional (Pro Level)

A higher level offers more commands and tools. Levels can be selected from the Tool bar or from the Options menu.

Experience Levels		
Icon	Level	Description
	Level 1	Displays list of commands and options at introductory level. Commands related to Level 2 and Pro are disabled.
	Level 2	Displays list of commands and options at advanced level. Commands related to Pro are disabled.
	Pro	Displays list of all commands and options.

Display of the Advanced Commands and the Vision Commands is activated by selecting **Options | Advanced Options**.

10.3. VIEW MENU

The following display options are available from the View menu:

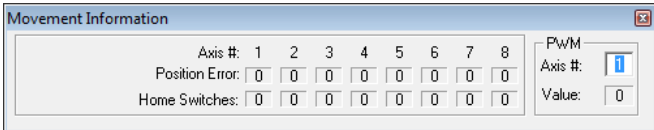
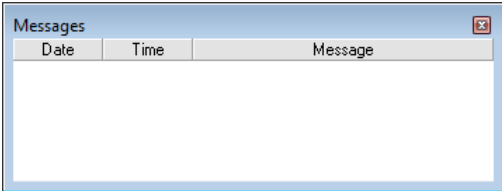
View Menu Options	
Option	Description
Movement information	<p>The Movement information dialog box, shown below, displays the following:</p> <ul style="list-style-type: none"> • Position error for all eight axes • Home switch status (for all eight axes). The number 1 indicates the switch is on (pressed) while 0 indicates the switch is off (released). • Selected axis (1 – 8) PWM value. The PWM value indicates the power sent to the axis motor. 
Messages	<p>The Messages dialog box, shown here, displays the content of the PS (Print To Screen) commands.</p> 

These two commands produce a window which overlaps the existing windows. The user should readjust the positions and sizes of these windows according to personal preference.

10.3.1. Dialog Bar Display Options

All Dialog bars are accessible from the View menu. Select **View | Dialog Bars**.

Dialog Bar Display Options	
Option	Description
Joints	Shows angle of the robot joints. For more information, see 5.10.3 Joints Dialog Bar on page 40.
XYZ	Shows position coordinates of the TCP. See 5.10.2 XYZ Dialog Bar on page 40.
Digital output	Shows digital output status and enables toggling an output status. For more information, see 8.3.1 Digital Inputs & Outputs Dialog Bars on page 80.
Digital input	Shows the digital input status. Enables toggling an input status in Off-Line mode, for program debugging. For more information, see 8.3.1 Digital Inputs & Outputs Dialog Bars on page 80.
Analog output	Displays the value (0-255) of Analog output 1 and 2. These values can also be modified through this dialog bar. For more information, see 8.3.2 Analog Inputs & Outputs Dialog Bars on page 81.
Analog input	Displays the value (0-255) of Analog inputs 1-4. Enables setting a value for an input in Off-Line mode, for program debugging. For more information, see 8.3.2 Analog Inputs & Outputs Dialog Bars on page 81.
Encoders	Shows the values of the eight encoders. For more information, see 5.10.1 Encoder Counts Dialog Bar on page 39.

Each of these options adds a dialog bar to the bottom of the screen, overlapping whatever windows are displayed. The user can retile the screen by reselecting the desired Window Layout Options from the Window menu.

11. Appendix: Command Line Options

The following table describes the command line options that enable the integration of user applications with SCORBASE.

Before operating SCORBASE with these command line options, follow and obey all warnings and cautions provided in the user application manuals to prevent, for example, hazards from moving parts.

The SCORBASE command line format that is required when using the options described in the table is provided, as follows:

SCORBASE.EXE [Optional INI File] [Optional Switches]

Command Line Options	
Option	Description
/O	Loads SCORBASE in online mode. For example, SCORBASE.EXE SCBS.INI /O
/S	Loads SCORBASE in simulation mode. For example, SCORBASE.EXE SCBS.INI /S
/H	Performs auto homing from online mode. For example, SCORBASE.EXE SCBS.INI /H
/L	Loads a specific workspace in simulation mode. For example, SCORBASE.EXE SCBS.INI /L="C:\PROGRAMES\INTELITEK\ROBOCELL\PROJECTS\ER4u\Er4Cell1.WS"
/R	Loads a specific workspace and runs SCORBASE. For example, SCORBASE.EXE SCBS.INI /R="C:\PROGRAM FILES\INTELITEK\ROBOCELL\PROJECTS\ER4u\Er4Cell1.WS"
/I	Open CIM Robot Device Driver configuration file. For example: SCORBASE.EXE /I=USBVD1.INI
/N	Open CIM Robot Device Driver number.
/T	Displays the SCORBASE application on top of the desktop at all times.

/U	Prevents the SCORBASE application from staying on top of the desktop. This command can be activated only when SCORBASE is open.
/M	Minimizes the SCORBASE application. This command can be activated only when SCORBASE is open.
/E	Restores the SCORBASE application. This command can be activated only when SCORBASE is open.
/C	Closes the SCORBASE application. This command can be activated only when SCORBASE is open.



/CIMDD_ONLINE	Open CIM-SCORBASE device driver mode: Online
/CIMDD_SIMUL_AUTO	Open CIM-SCORBASE device driver mode: Simulation
/CIMDD_STANDALONE_ONLY	Open CIM-SCORBASE device driver mode: Standalone

Examples of SCORBASE command line procedures are provided, as follows:

Loading a workspace in simulation mode:

- At the prompt, type the following:
SCORBASE.EXE /S /L="C:\PROGRAM FILES\INTELITEK\
ROBOCELL\PROJECTS\ER9u\Act3.WS". The workspace is loaded in simulation mode.

Loading the software in online mode and homing the robot:

- At the prompt, type the following:
SCORBASE.EXE /O /H /R="C:\PROGRAM
FILES\INTELITEK\ROBOCELL\PROJECTS\ER4u\Er4Cell1.WS". The workspace is loaded in online
mode and the robot is homed.